

## THE QUALIFICATIONS

This product should only be fitted by a qualified plumber to NVQ (National Vocational Qualification) or SNVQ (Scottish National Vocational Qualification) Level 3. Should the installation be completed by a non-qualified person then the guarantee may be considered invalid.

For a claim made under our warranty written certification of your installers credentials can be required. For further information or to find a qualified installer in your area please visit the Institute of Plumbers website - [www.iphe.org.uk](http://www.iphe.org.uk)

At present, to be a plumber you need to follow the National Vocational Qualification (NVQ) route (Scottish National Vocational Qualification - SNVQ - in Scotland). These qualifications are made up of theory and practical work in the classroom/purpose built training facility and work based experience with a working plumber. Colleges should help students find a work placement, although many students organise it themselves. The S/NVQ qualification works in levels. All recently qualified plumbers should hold S/NVQ Level 2 as basic with Level 3 as the preferred level. Level 2 will give you the foundation you need for a career in plumbing and teach you domestic plumbing to a satisfactory level. Level 3 is more comprehensive and deals with domestic, commercial and industrial plumbing along with aspects such as gas - if you want to one day set up your own business, this is the level to reach. The Institute of Plumbing and Heating Engineering, and the industry as a whole recommends that all plumbers reach a minimum of Level 3.

Reaching Level 3 has other advantages. The Institute runs a Master Plumber Certificate, which only those attaining Level 3 or equivalent can reach as long as they have the relevant experience as well. Those with S/NVQ Level 3 can (once in membership with the Institute for five years as a Member MIPHE) gain Engineering Technician EngTech status with the Engineering Council (UK).

For any further information please contact  
Crosswater on: **0845 873 8840**

Or visit our web-site at [www.crosswater.co.uk](http://www.crosswater.co.uk)

The manufacturer reserves the right to make technical  
modifications without prior notice.

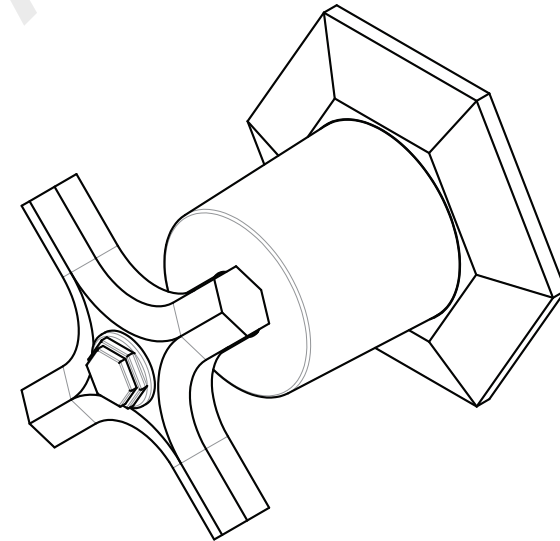
INSTALLATION  
INSTRUCTIONS**Wall Stop Taps**

## INTRODUCTION

**Please read these instructions carefully and keep in a safe place for future reference.**

**General Installation Guide**

This guide contains all the necessary fitting information for the tap.

Please read all the instructions carefully before beginning the installation. Care taken during the installation will ensure long life and trouble free operations from the tap.

It is very important that all pipe work is flushed thoroughly after installation to avoid damaging the ceramic discs.

## PARTS LIST

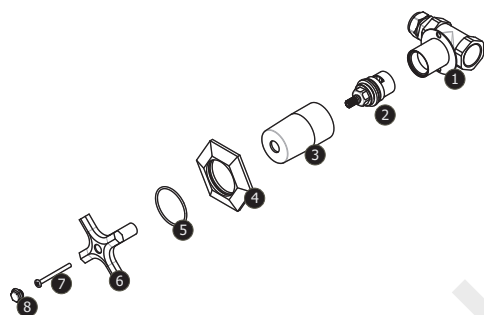

The set comprises of the following:

- 1 - "T"-valve (x2)
- 2 - Ceramic Valve (x2)
- 2 - Chrome collar (x2)
- 3 - Valve cover (x2)
- 4 - Escutcheon (x2)
- 5 - O-Ring (x2)
- 6 - Handwheel (x2)
- 7 - Retaining screw (x2)
- 8 - Indices (x2)

Check that all parts are present.

Fig. 1

## INSTALLATION

First shut off your water heating system then, with your mains stop cock closed, open the lowest hot and cold taps in the house and allow to run until the cold storage tank and pipes are empty (the hot water storage cylinder always remains full).

Fitting isolating valves to the inlet feeds is recommended for ease of maintenance.

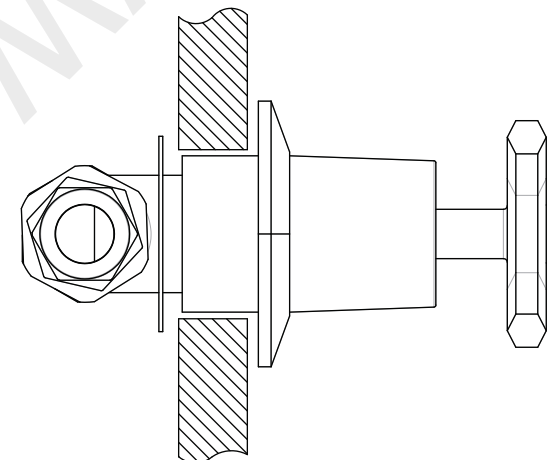

Fig. 2

**INSTALLATION**

**Remember to turn off the mains water supply before connecting to any existing pipe work.**

- Identify all components before fitting;
- Fix the "T"-valve to the wall;
- Screw the valve cover and slide the chrome collar until it faces the wall;
- Finish the installation fitting the handwheel;
- Connect both hot and cold water supplies;
- To check for joint and connection leaks, turn on the water supplies and open both taps letting the water flow for a few minutes;
- Remedy if required.

## CLEANING

The chrome plate we use on our taps is very durable, nevertheless care should be taken when cleaning them. They should be cleaned only with warm soapy water followed by rinsing with clean water and drying with a soft cloth. All finishes are vulnerable to acid attack and some strong substances such as household cleaners, disinfectants, denture cleaners, hair dyes can cause damage to the surface.