

TRITON

86004490

Bath Shower
Mixer

**REGISTER ONLINE
ENTER A PRIZE DRAW**

**WIN
£100**

LOVE2SHOP VOUCHERS

VISIT OUR WEBSITE TODAY

TRITONSHOWERS.CO.UK/REGISTER

*PRODUCT REGISTRATION IS ONLY AVAILABLE
TO UNITS PURCHASED & INSTALLED IN THE UK*

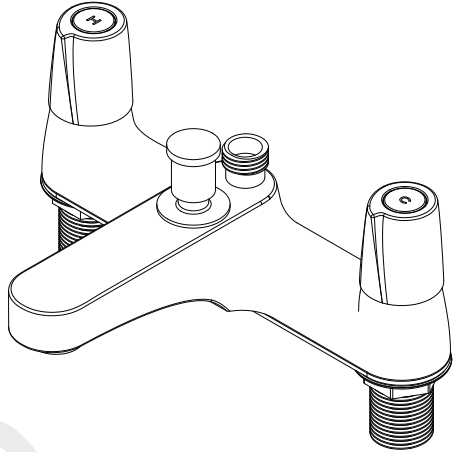

FOR YOUR SERVICE REFERENCE

NOTE DOWN THE PRODUCT CODE BELOW
(FROM THE LABEL ON THE FRONT OR TOP OF THE BOX)

ALTERNATIVELY REGISTER BY TEL: 024 7637 8321

IMPORTANT SAFETY ADVICE

The shower head and hose supplied with this product are a safety critical part of your shower. Failure to use genuine Triton parts may cause injury and invalidate your guarantee.

INSTALLATION AND OPERATING INSTRUCTIONS

Please read this book thoroughly and familiarise yourself with all instructions before commencing installation and keep it for future reference.

The mixer shower installation **MUST** be carried out by a suitably qualified person, **in the sequence of this instruction book.**

CONTENTS

Page

MAIN COMPONENTS.....	1
INTRODUCTION.....	2 -3
TYPICAL DOMESTIC INSTALLATIONS.....	4 - 6
PREPARING THE SHOWER.....	7
SITING OF THE SHOWER.....	7
SUPPLY PIPEWORK.....	7
OPERATING THE SHOWER.....	8
DIMENSIONS.....	9
FLOW RATES.....	10
GUARANTEE, SERVICE POLICY, ETC.....	rear cover

INSTALLERS PLEASE NOTE THESE INSTRUCTIONS ARE TO BE LEFT WITH THE USER

To check the product suitability for commercial and multiple installations, please contact Triton's specification advisory service before installation. Please see back of book for contact information.

MAIN COMPONENTS

Fig. 1

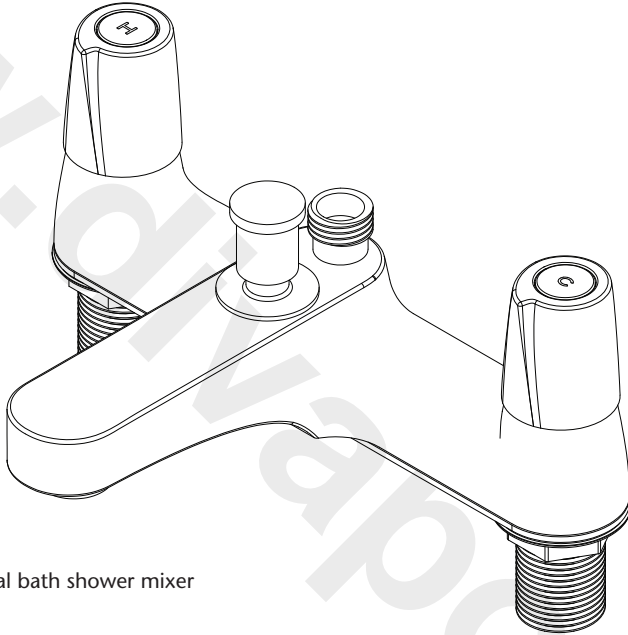

Manual bath shower mixer

INTRODUCTION

This book contains all the necessary fitting and operating instructions for your Triton mixer shower. Please read them carefully and read through the whole of this book before beginning your installation.

The shower installation must be carried out by a suitably competent person and in sequence of this instruction book.

Care taken during the installation will give a long and trouble free life from your mixer shower.

SITE REQUIREMENTS

The installation must be in accordance with Water Regulations and Bylaws.

Water pressure requirements

Running water pressure:

0.1 bar min.

10 bar max.

Maximum static water pressure:

Gravity and mains - 10 bar

This mixer shower is designed for all pressures found in the UK.

For effective operation of the internal seals, the maximum static pressure must not be exceeded.

Water Minimum Flow Rate

For best performance within the specified running pressure range a minimum flow of 8 litres per minute should be available to both inlets.

Water Temperature Requirements

Maximum hot water temperature: = 80°C

Recommended maximum: = 65°C

Minimum hot water temperature: = 52°C

Maximum cold water temperature: = 20°C

The mixer shower MUST NOT be subjected to water temperatures above 80°C.

BS 6700 recommends that the temperature of stored water should never exceed 65°C.

A stored water temperature of 60°C is considered sufficient to meet all normal requirements and will minimise the effects of scale in hard water areas.

SAFETY WARNINGS

- DO NOT** choose a position where the shower could become frozen.
- DO NOT** connect this mixer shower to any form of tap or fitting not recommended by the manufacturer.
- DO NOT** allow the inlet pressure or flow rates to operate outside the guidelines laid out in 'site requirements'.

IMPORTANT: This B.S.M is not thermostatic and will not stop water flowing if there is a loss of either supply.

PLUMBING REQUIREMENTS

DO NOT use jointing compounds on any pipe fittings for the installation.

DO NOT solder fittings near the mixer unit as heat can transfer along the pipework and damage the mixer valve.

IMPORTANT:

- The layout and sizing of pipework **MUST** be such that nominally equal inlet supply pressures are achieved and the effects of other draw-offs are minimised.
- The pipework should be installed such that other taps and appliances being operated elsewhere on the premises do not significantly affect the flow
- When connecting pipework avoid using tight 90° elbows; swept or formed bends will give the best performance.
- The hot water pipe entry must be made to the left-hand side inlet, marked HOT, 'H' or with a red/orange label.
- Suitable isolating valves (complying with Water Regulations and Bylaws) must be fitted on the hot and cold water supplies to the shower as an independent means of isolating the water supplies should maintenance or servicing be necessary.
- It is preferable to flush the pipework to clear the system of debris and check for leaks before connecting to the mixer.
- The mixer inlets contain removable filters that may become blocked if debris is not flushed through before fitting.

Commercial Applications

- Triton recommends for all commercial applications that, easily accessible, in-line filters are used to aid maintenance.

Hard Water Areas

- a. If it is intended to operate the shower in areas of hard water (above 200-ppm temporary hardness), a scale inhibitor may have to be fitted. For advice on the Triton scale inhibitor, please contact Customer Experience.
- b. For best performance the shower head **MUST** be regularly cleaned to remove scale and debris.

WATER SYSTEM REQUIREMENTS

This mixer shower is suitable for:

- Pumped gravity systems
- Gravity
- Fully modulating type combination boilers
- Multi-point hot water heaters
- Thermal storage
- Unvented systems

When installing this mixer with a combination or multi-point boiler, it may be necessary to install flow regulation.

Check that the appliance is capable of delivering hot water at a minimum switch-on flow rate of 3 litres per minute. At flow rates between 3 and 8 litres per minute, the appliance must be capable of raising the water temperature to 52°C minimum.

Water temperature at the inlet of the mixer valve must remain relatively constant when flow rate adjustments are made - refer to the appliance operating manual to confirm compatibility with this mixer shower.

Where thermal store systems and instantaneous gas water heaters are used, if excessive draw-off takes place the appliance may not be able to maintain an adequate output temperature. This could result in the shower temperature becoming noticeably cooler.

Flow regulators can be fitted with high-pressure water systems to reduce flow rate and assist economy.

***Fig.2**

*Diagrammatic view – not to scale. For illustration purposes only.

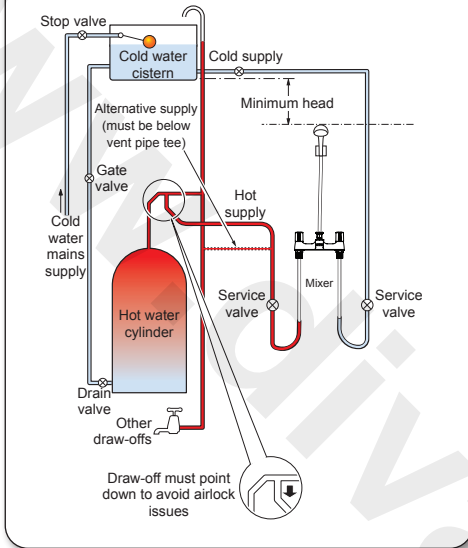

Domestic Gravity Fed Systems (fig.2)

The bath shower mixer MUST be fed from a cold water cistern and hot water cylinder providing nominally equal pressures. There MUST be a minimum of one metre head of water. The minimum head distance is measured from the base of the cold water cistern to top of the shower head. If valves are gravity fed then supply pressure should be verified to ensure conditions of use are appropriate for the valve.

***Fig.3**

*Diagrammatic view – not to scale. For illustration purposes only.

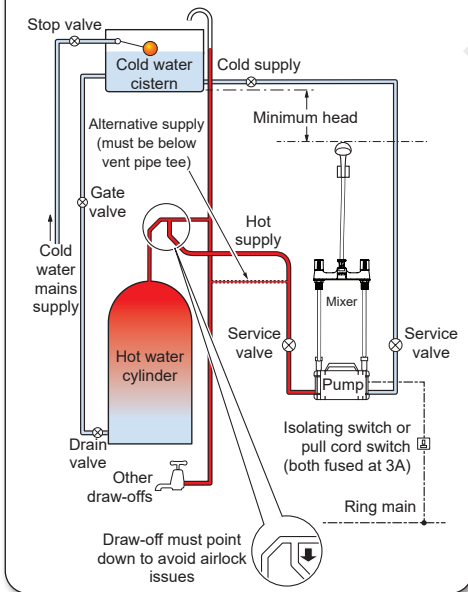

TYPICAL DOMESTIC INSTALLATIONS Pumped gravity fed systems (fig.3)

The bath shower mixer MUST be fed from a cold water cistern and hot water cylinder providing nominally equal pressures. The mixer unit may be used with a gravity fed system with a pump to boost pressures as shown; please refer to the pump installation guide to establish the minimum head requirements for automatic operation of the pump.

Instantaneous Gas-heated Systems, e.g. combination boilers (fig.4)

The bath shower mixer **MUST** be installed with a multi-point gas water heater or combination boiler of a fully modulating design i.e. to maintain relatively stable hot water temperatures. An expansion vessel **MAY** be fitted, and regularly maintained, to prevent the shower mixer being damaged by excess pressures. This may already be installed within the boiler (check with manufacturer) and is in addition to the normally larger central heating expansion vessel.

***Fig.4**

*Diagrammatic view – not to scale. For illustration purposes only.

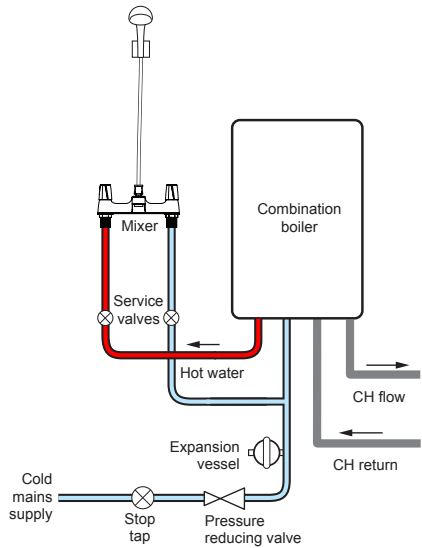

Unvented Mains Pressure Systems (fig.5)

The bath shower mixer can be installed with an unvented, stored hot water cylinder.

For systems with no cold water take off after the appliance reducing valve, it will be necessary to fit an additional drop tight pressure reducing valve when the mains pressure is over 5 bar. The drop tight pressure reducing valve must be set at the same value as the unvented package pressure reducing valve.

NOTE: An additional expansion vessel may be required if a second pressure reducing valve is installed. This does not apply to packages with a cold take off after the pressure reducing valve to the cylinder.

***Fig.5**

*Diagrammatic view – not to scale. For illustration purposes only.

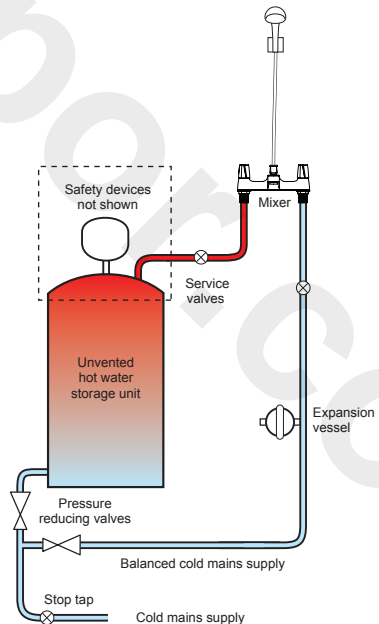

***Fig.6**

*Diagrammatic view – not to scale.
For illustration purposes only.

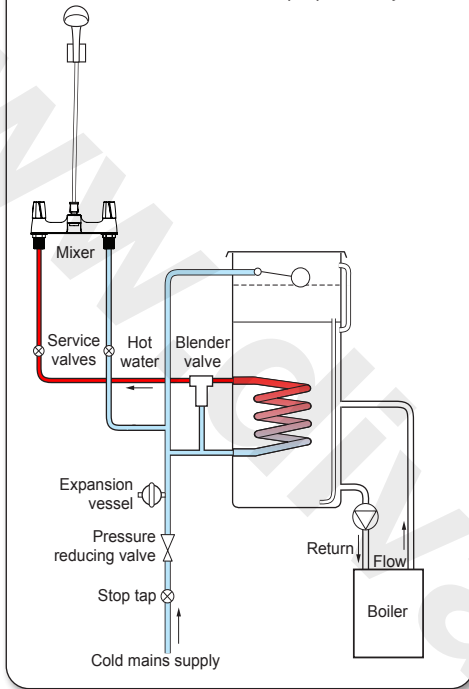

Mains Pressurised Thermal Store Systems (fig.6)

Packages of this type, fitted with a tempering valve (blender valve) can be used. An expansion vessel **MUST** be fitted and regularly maintained to ensure the unit is not damaged by excess pressures. This may already be installed externally or internally within the thermal store (check with thermal store manufacturer).

INSTALLATION

PREPARING THE SHOWER

Check the contents to make sure all parts are present.

Before starting the installation, make sure all the openings on the valve are carefully covered to stop ingress of any debris etc. while routing the supply pipework.

The shower is suitable for exposed installation onto the top surface of a bath tub.

SITING OF THE SHOWER AND ACCESSORIES

Refer to **fig.7** for correct siting of the shower.

The mixer shower should be positioned as detailed, with all controls within comfortable reach of the user.

The accessories (shower head, riser rail and / or fixed shower head) can be positioned above or to either side of the shower.

Connect to the bath shower mixer using 3/4 BSP tap connector fitting.

LEAK TESTING

Fit the hose to the outlet and direct it to waste. Open the isolating valves to the bath shower mixer and check for leaks. Remedy any leaks found.

COMMISSIONING

Important: Make sure that all supply pipework has been flushed through before commissioning.

Start the water flow by rotating the hot and cold controls.

***Fig.7**

*Diagrammatic view – not to scale.
For illustration purposes only.

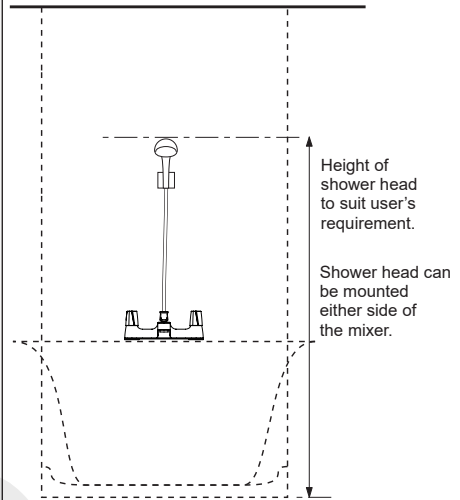

OPERATING THE BATH SHOWER MIXER

To start the bath shower mixer rotate either or both the hot (clockwise for flow) and cold (anti-clockwise for flow) controls, adjusting each individually to achieve the desired showering temperature. Further rotating the controls will increase the flow rate.

To stop the water flow rotate both hot and cold controls back to their original starting position.

USING THE SHOWER SETTING

To use the shower setting pull the diverter up (**fig.14**) and to return to the tap setting, push down on the diverter (**fig.15**).

Caution: Exposed metal surfaces may become hot during use.

Fitting the Fixed Shower Head Holder (if supplied)

Decide on the position for the shower head holder
Proceed as follows:

Hold the shower head holder mounting plate in a suitable position on the wall. Using the plate as a template, mark two locating holes (**fig.16**).

Drill and plug the wall. The wallplugs provided are suitable for most brick walls – use an appropriate masonry drill, but if the wall is plasterboard or a soft building block, use special wallplugs and an appropriate drill bit.

Replace the mounting plate and secure using the fixing screws supplied.

Slide the shower head holder down onto the mounting plate (**fig.16**) until it clicks into place.

Fig.14

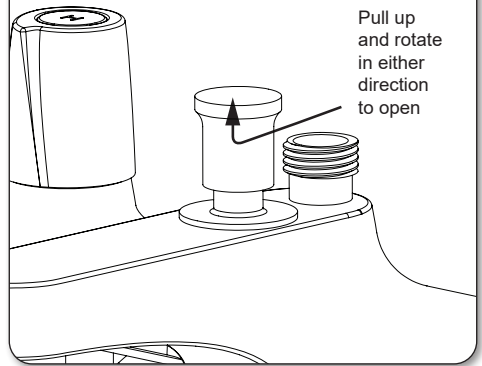

Fig.15

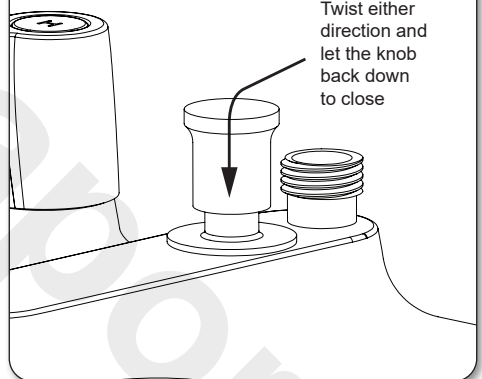
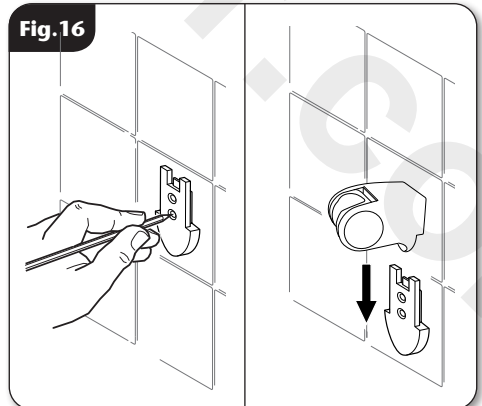
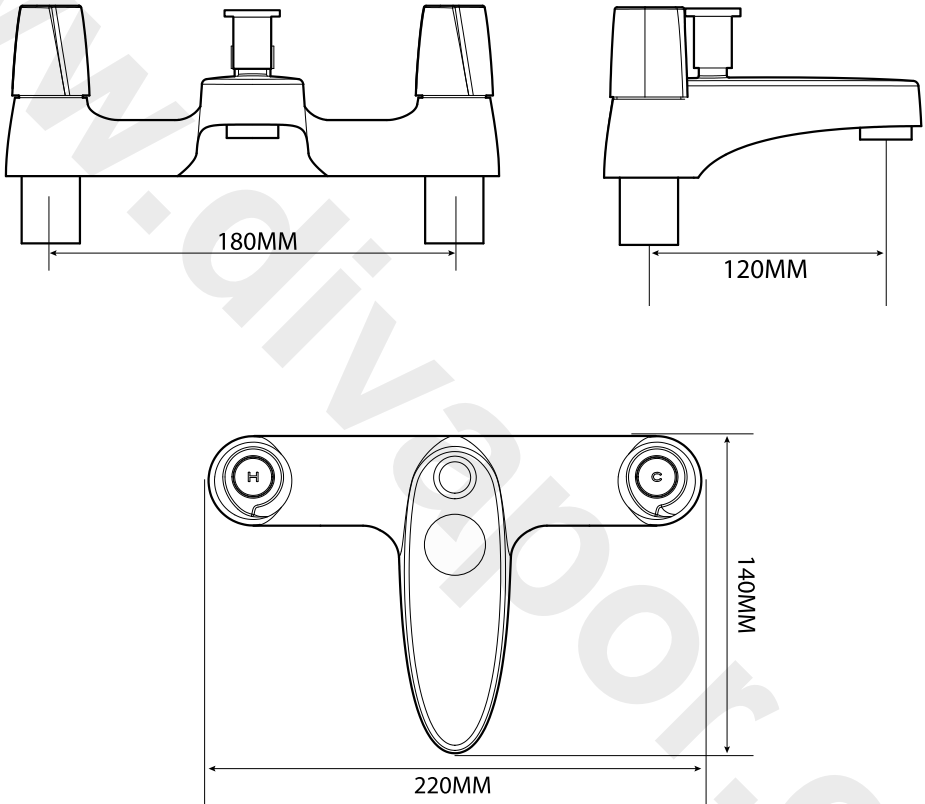

Fig.16



Bath shower mixer

DIMENSIONS - All dimensions regarding the product and installation are approximate.



PRODUCT FLOW RATES

Shower Flow Rate (l/m)	9.0	15.0	18.0	21.0	23.0	33.0	42.0	49.0	55.0	61.0
Bath Flow Rates (l/m)	15.0	22.5	25.0	31.5	38.0	55.5	73.5	91.5	93.5	93.5
Pressure (bar)	0.1	0.2	0.3	0.4	0.5	1.0	2.0	3.0	4.0	5.0

Conditions for test

Flow control fully open.

Open outlet - No hose or shower head connected.

Important

Product flow rates are for guidance only.

www.divapor.com

www.divapor.com

www.divapor.com

UK SERVICE POLICY

In the event of a product fault or complaint occurring, the following procedure should be followed:

DO NOT REMOVE THE PRODUCT

1. Telephone Customer Experience on **024 7637 2222** having available your details including post code, the model number and power rating of the product, together with the date of purchase and, where applicable, details of the particular fault.
2. If required, the Customer Experience Advisor will arrange for a qualified engineer to call.
3. All products attended to by a Triton service engineer must be installed in full accordance with the Triton installation guide applicable to the product. Every product pack contains an installation guide, however, they can also be downloaded free at www.tritonshowers.co.uk.
4. Our engineer will require local parking and if a permit is required, this must be available to the engineer on arrival at the call.
5. If loft access is required for isolation or to complete a repair, the loft must have a fixed access ladder and be boarded, with appropriate lighting from the access point to and around the repair area.
6. It is essential that you or an appointed representative (who must be over 18 years of age) is present for the duration of the service engineer's visit. If the product is in guarantee you must produce proof of purchase.
7. Where a call under the terms of guarantee has been booked and the failure is not product related (i.e. scaling and furring, incorrect water pressure, pressure relief device operation or electrical/plumbing installation fault) a charge will be made. A charge will also be issued if nobody is at the property when the service engineer calls or adequate parking/permit is not available.
8. If the product is no longer covered by the guarantee an up-front fixed fee will be charged before the site visit.
9. Your receipt must be retained as proof of purchase. Should proof of purchase not be available on an 'in-guarantee' call, or should the service engineer find that the product is no longer under guarantee, the engineer will charge the same fixed price and will request payment prior to departing. If payment is not made on the day an administration charge will be added to the fixed charge.
10. If a debt is outstanding from a previous visit, or from any other Triton purchase, Triton reserves the right to withhold service until the debt has been settled.
11. Triton takes the health, safety and wellbeing of its employees very seriously and expects customers to treat all staff members with respect. Should any employee feel threatened or receive abuse, either verbally or physically, Triton reserves the right to withhold service.

Replacement Parts Policy

In line with AMDEA guidelines, Triton retains functional spares for as long as there is a market for them and in most cases, well beyond. Due to the vast array of product types, the life cycle of products can vary and therefore so can the length of time parts can be supplied. Spare parts can be ordered via our online spare parts store or by telephoning our Triton Customer Experience team on **024 7637 2222**. Payment should be made by credit / debit card (excluding American Express or Diners Card). Payment can also be made by pre-payment of a pro-forma invoice, by cheque or postal order.

Telephone orders are based on information given during the call. Before contacting Triton, please verify your requirements using the information contained in the user guide. Triton cannot accept liability for incorrect part identification.

Triton Showers
Triton Road
Nuneaton
Warwickshire, CV11 4NR

Triton is a division of Norcros Group (Holdings) Limited

Triton reserve the right to change product specification without prior notice. E&OE. © TRITON SHOWERS 2022

TRITON UK STANDARD GUARANTEE

This guarantee applies only to products installed within the United Kingdom and does not apply to products used expressly for commercial gain, unless this use has been specified by Triton. This guarantee does not affect your statutory rights.

With the exception of accessories, Triton guarantee the product against all manufacturing defects for a period of **5 years** for use in a domestic environment from the date of purchase, provided that it has been installed by a competent person in full accordance with the fitting instructions.

All accessories such as shower heads, hoses and riser rails carry a **1 year** parts only guarantee against manufacturing defects.

Any part found to be defective during this guarantee period we undertake to repair or replace at our option without charge, so long as it has been properly maintained and operated in accordance with the instructions and has not been subject to misuse or damage or the effects of limescale build up. This product must not be taken apart, modified or repaired except by a person authorised by Triton.

What is not covered:

1. Breakdown due to:
 - a) use other than domestic use by the property occupants;
 - b) wilful act or neglect;
 - c) any malfunction resulting from the incorrect use or quality of electricity, gas or water or incorrect setting of controls;
 - d) failure to install in accordance with this installation guide.
2. Claims for missing parts once the product has been installed.
3. Repair costs for damage caused by foreign objects or substances.
4. Total loss of the product due to non-availability of parts.
5. Compensation for loss of use of the product or consequential loss of any kind.
6. Call out charges due to an abortive visit or where no fault has been found with the appliance.
7. The cost of repair or replacement of isolating switches, electrical cable, fuses and/or circuit breakers or any other accessories installed at the same time. Replacement of the Pressure Relief Device that only activates when the shower outlet is blocked is also excluded.
8. The cost of routine maintenance, adjustments, overhaul modifications or loss or damage arising therefrom, including the cost of repairing damage, breakdown, malfunction caused by corrosion, furring, frost or exposure to freezing conditions.
9. Call out charges where the water supply cannot be isolated, this includes consequential losses arising from unserviceable supply valves, or inaccessible product or valves located in a loft space without suitable access.

For the latest Terms & Conditions please see:

www.tritonshowers.co.uk/terms

PLEASE NOTE PRODUCT REGISTRATION IS ONLY AVAILABLE TO UNITS PURCHASED & INSTALLED IN THE UK

Customer Experience: **024 7637 2222**

Trade Installer Hotline: **024 7637 8344**

www.tritonshowers.co.uk

E-mail: serviceenquiries@tritonshowers.co.uk

E-mail: technical@tritonshowers.co.uk