

# ***INCLUSIVE*** ***Riser Rail Kit***

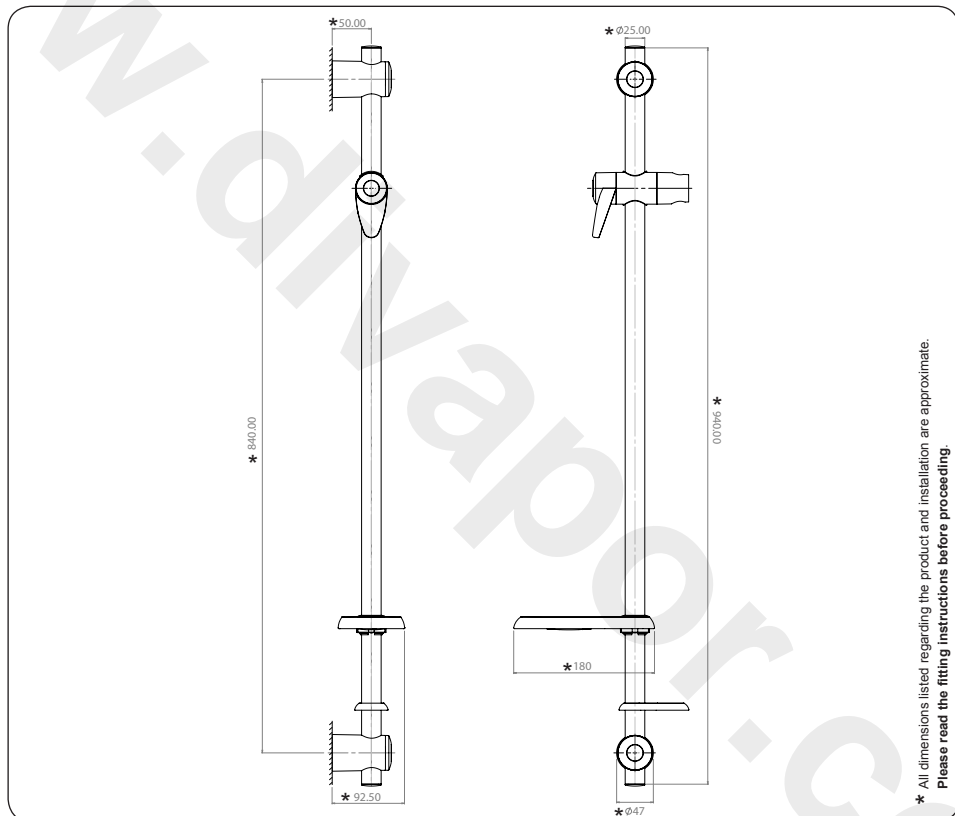

## **Installation Instructions**

INSTALLERS PLEASE NOTE THESE INSTRUCTIONS ARE TO BE LEFT WITH THE USER

## FITTING THE RISER RAIL ASSEMBLY

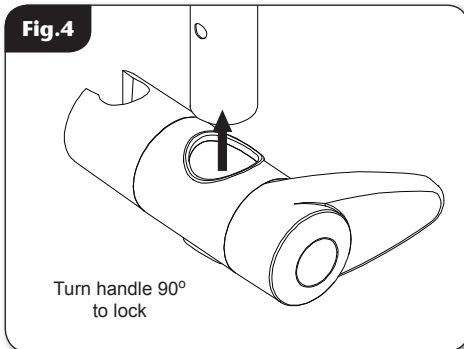
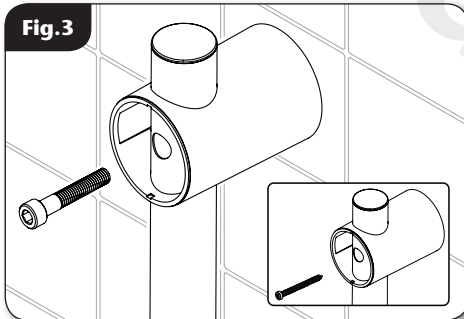
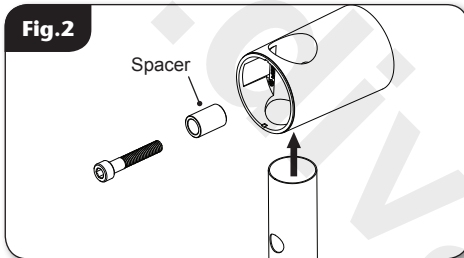
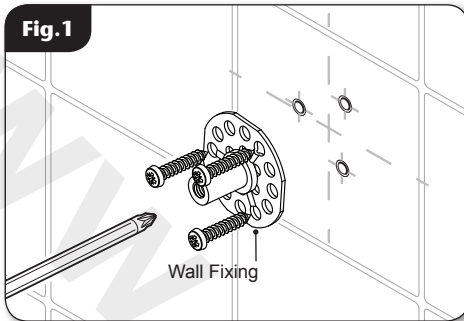

### WARNING!

**Check there are no hidden cables or pipes before drilling holes for wall plugs. Use great care when using power tools near water. The use of a residual current device (RCD) is recommended when using power tools.**

- Place the riser rail to the wall and use both of the fixing holes to mark the position of the top and bottom wall fixing. Position the wall fixing in place and use it to mark out the number of screw holes you wish to drill. Remove the wall fixing then drill and plug the wall. An appropriate drill bit should be used. If the wall is brick, plasterboard or a soft building block, appropriate wall plugs and screws should be fitted.
- Replace the wall fixing to the wall and secure in place with the desired number of screws (**Fig. 1**).

**Note: Screws are not supplied with kit.**

- Fit the top bracket onto the wall fixing and insert the spacer. Slide the riser rail into the bracket and line up the fixing holes (**fig. 2**).
- Note: The larger of the two holes in the top and bottom of the riser rail should be facing outwards when the holes are aligned with the fixing hole in the bracket.**

- Use the supplied M6 cap head screw (5mm hexagonal wrench) to fix the riser rail and bracket to the wall fixing (**fig. 3**). When secured fit the bracket cap to the bracket.
- Alternatively a single screw and suitable wall plug (not supplied) can be used in place of the supplied cap head screw and wall fixing. (**fig. 3**).
- Fit the showerhead holder onto the riser rail. Turn the lever anti-clockwise to release the locking mechanism, then slide the holder onto the rail (**fig. 4**). To secure the holder in place, turn the lever clockwise.

## FITTING THE RISER RAIL ASSEMBLY

- Slide the soapdish and hose retainer onto the bottom of the riser rail, below the holder (**fig.5**).
- Fit the bottom bracket, with spacer already inserted, onto the riser rail and screw to the bottom wall fixing.

**Note:** *The screw should pass through the larger hole in the base of the riser rail (fig.6) and come to rest against the inner of the riser rail to stop it from turning within the bracket.*

- Fit the end caps onto both brackets. The end caps will only fit one way. Fit the riser rail trims to both ends of the rail.

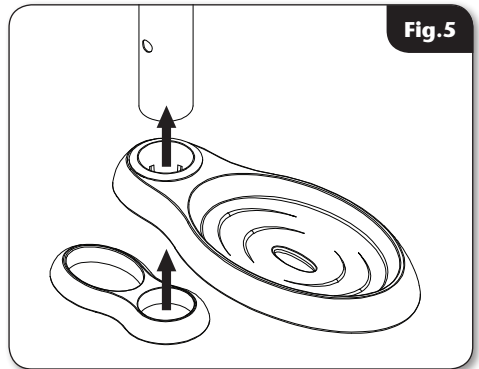

**Fig.5**

## FITTING THE HOSE AND SHOWERHEAD

- Feed the flexible hose through the ring on the hose retainer. This is to comply with Water Regulations.
- Screw the flexible hose to the shower outlet and showerhead, making sure the supplied washers are in place at both ends of the flexible hose (**fig.7**).
- Place the showerhead into the holder and check that it fits correctly (**fig.8**).

**Note:** *The holder is slightly tapered and the showerhead and hose will only fit from one direction.*

**IMPORTANT:** It is the conical end of the hose which grips into the holder. The showerhead will not fit in the holder without the hose attached.

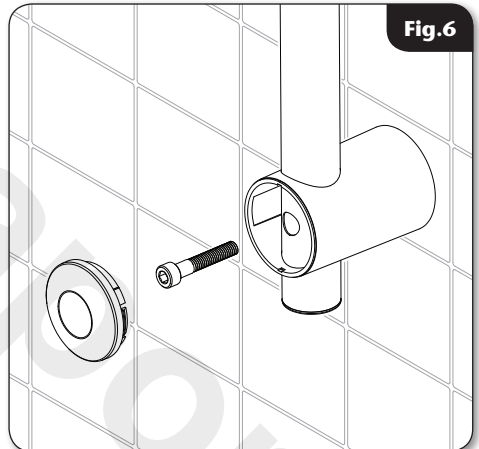

**Fig.6**

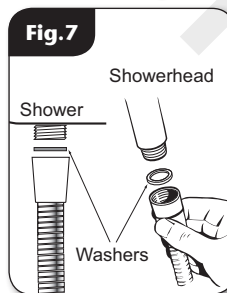

**Fig.7**

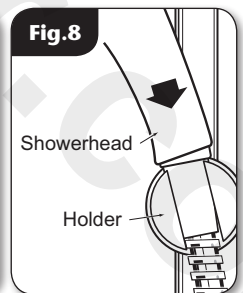

**Fig.8**

## SPARE PARTS

<b>Ref.</b>	<b>Description</b>	<b>Part number</b>
<b>1</b>	Bracket Set* Bracket / Cap <i>White</i> <i>Chrome</i>	83315380 83315390
<b>2</b>	Riser Rail 25 mm <i>Stainless Steel</i>	88800037
<b>3</b>	S/Head Holder <i>White/grey</i> <i>Chrome/grey</i>	P84200110 P84200120
<b>4</b>	Soap Dish	586100380
<b>5</b>	Hose Retainer <i>White</i> <i>Chrome</i>	7054532 7054546
<b>6</b>	Bracket Cap <i>White</i> <i>Chrome</i>	7054530 7054545
<b>7</b>	Wall Fixing Set Wall Fixing / M6 Cap Head Screw / Spacer	83315400
	Full Kit <i>White/grey</i> <i>Chrome/grey</i>	88900039 88900045

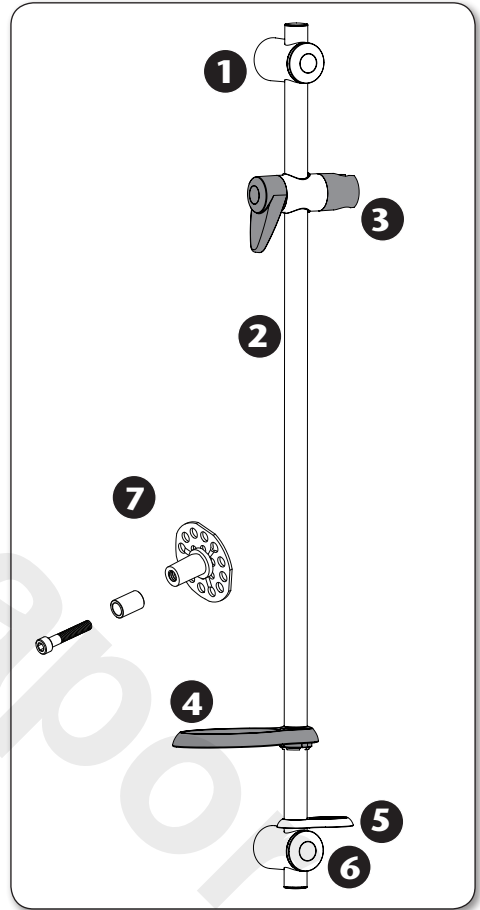

\* Bracket Set for both white and chrome contains 2 of each component.

**Please refer to shower installation and operating instructions for service details. E&OA.**