

TRITON

EDEN

Thermostatic
Bar Diverter

**REGISTER ONLINE
ENTER A PRIZE DRAW**

**WIN
£100**

LOVE2SHOP VOUCHERS

VISIT OUR WEBSITE TODAY

TRITONSHOWERS.CO.UK/REGISTER

*PRODUCT REGISTRATION IS ONLY AVAILABLE
TO UNITS PURCHASED & INSTALLED IN THE UK*



86005000

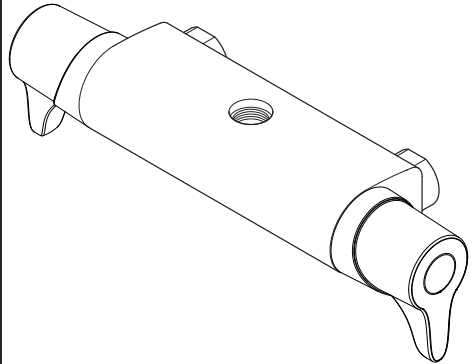

FOR YOUR SERVICE REFERENCE

NOTE DOWN THE PRODUCT CODE BELOW
(FROM THE LABEL ON THE FRONT OR TOP OF THE BOX)

ALTERNATIVELY REGISTER BY TEL: 024 7637 8321

IMPORTANT SAFETY ADVICE

The shower head and hose supplied with this product are a safety critical part of your shower. Failure to use genuine Triton parts may cause injury and invalidate your guarantee.

INSTALLATION AND OPERATING INSTRUCTIONS

Please read this book thoroughly and familiarise yourself with all instructions before commencing installation and keep it for future reference.

The mixer shower installation **MUST** be carried out by a suitably qualified person, **in the sequence of this instruction book.**

| CONTENTS | Page |
|---|-------------|
| DIMENSIONS AND MAIN COMPONENTS | 1 |
| INTRODUCTION..... | 2 |
| SITE REQUIREMENTS | 2 |
| SAFETY WARNINGS | 2 |
| PLUMBING REQUIREMENTS | 3 |
| WATER SYSTEM REQUIREMENTS..... | 3 |
| TYPICAL DOMESTIC INSTALLATIONS..... | 4 - 6 |
| INSTALLATION..... | 7 |
| PREPARING THE SHOWER | 7 |
| SITING OF THE SHOWER | 7 |
| FITTING THE RISER PIPE/FIXED HEAD..... | 8 - 9 |
| LEAK TESTING | 9 |
| COMMISSIONING..... | 10 |
| FITTING THE CONTROLS..... | 10 |
| ADJUSTING THE MAXIMUM TEMPERATURE STOP SETTING..... | 10 |
| TEMPERATURE ADJUSTMENT RANGE..... | 11 |
| RECOMMENDED OUTLET TEMPERATURES | 11 |
| OPERATING THE SHOWER (DIVERTER)..... | 12 |
| TMV2 AND FLOW RATES | 13 |
| MAINTENANCE | 14 |
| FAULT FINDING..... | 15 - 16 |
| GUARANTEE, SERVICE POLICY, ETC. | rear cover |



Find our step-by-step installation video for this product on our YouTube channel. Go to [youtube.com/TritonShowers](https://www.youtube.com/TritonShowers) and search for 'how to guides'.

To check the product suitability for commercial and multiple installations, please contact Triton's specification advisory service before installation. Please see back of book for contact information.

Thermostatic bar mixer shower

DIMENSIONS

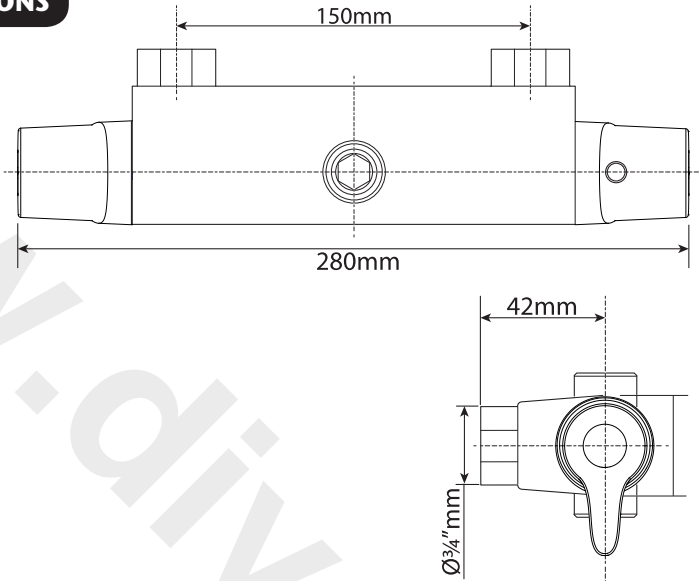

All dimensions listed in this fitting book regarding the product and installation are approximate.

MAIN COMPONENTS

1. Fixed spray arm
 2. Fixed shower head
 3. Rigid riser rail pipe
 4. Handset
 5. Handset holder
 6. Hose
 7. Eden thermostatic mixer valve
 8. Collar & outlet assembly
- Arm mounting plate (*not shown*)

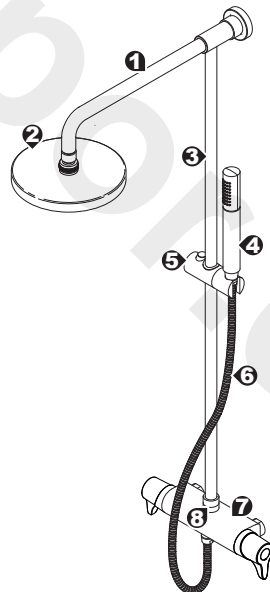

INTRODUCTION

This book contains all the necessary fitting and operating instructions for your mixer shower. Please read them carefully and read through the whole of this book before beginning your installation.

The shower installation must be carried out by a suitably competent person and in sequence of this instruction book.

Care taken during the installation will give a long and trouble free life from your mixer shower.

SITE REQUIREMENTS

The installation must be in accordance with water supply (water fittings) regulation 1999 and/or local Bylaws.

| | |
|---------------------------------|--------------------------|
| Maximum static pressure (Bar) | 10 |
| Flow pressure, Hot & Cold (Bar) | 0.5 to 5 |
| Hot supply temperature (°C) | 55 to 65 |
| Cold supply temperature (°C) | Equal to or less than 25 |

This mixer shower is designed for high pressure systems found in the UK, but can be installed with low pressure gravity water systems with reduced flow rates.

For effective operation of the internal seals, the maximum static pressure must not be exceeded.

NOTE: Valves operating outside these conditions cannot be guaranteed by the buildcert scheme to operate as Type 2 valves.

A stored water temperature of 60°C is considered sufficient to meet all normal requirements and will minimise the effects of scale in hard water areas.

Pressure Reducing Valve

On sites where the running pressure is above 5 bar, the use of a suitably sized pressure reducing valve fitted in the cold mains supply pipework can provide nominally equal pressures at the mixer shower.

Water Minimum Flow Rate

For best performance within the specified running pressure range a minimum flow of 8 litres per minute should be available to both inlets.

Water Temperature Adjustment and Thermal Safety

The mixed water temperature can be adjusted from cold through to a top limit which must be preset during installation with full anti-scald protection throughout the range (35°C to 40°C) providing the hot water temperature at the inlet remains 10°C above the outlet temperature.

Should there be a loss of flow to either incoming supply then water from the shower will stop or be reduced until both supplies are restored.

SAFETY WARNINGS

- DO NOT** choose a position where the mixer shower could become frozen.
- DO NOT** connect this mixer shower to any form of tap or fitting not recommended by the manufacturer.
- DO NOT** allow the inlet pressure or flow rates to operate outside the guidelines laid out in Site Requirements.
- DO NOT** connect the mixer shower to a gravity hot supply and a mains cold supply or vice versa.

APPROVALS

This mixer valve has the following approvals

- WRAS**
- TMV2** (BS EN 1111)

Designation: **HP-S** (high pressure shower only)

On pressures above 0.5 bar.

PLUMBING REQUIREMENTS

DO NOT use jointing compounds on any pipe fittings for the installation.

DO NOT solder fittings near the mixer shower as heat can transfer along the pipework and damage the mixer valve.

DO NOT subject the unit to a water temperature above 80°C during installation, use, maintenance or disinfection.

IMPORTANT:

- The layout and sizing of pipework **MUST** be such that nominally equal inlet supply pressures are achieved and the effects of other draw-offs are minimised.
- The pipework should be installed such that other taps and appliances being operated elsewhere on the premises do not significantly affect the flow.
- When connecting pipework avoid using tight 90° elbows; swept or formed bends will give the best performance.
- The hot water pipe entry **MUST** be made to the left-hand side inlet, marked HOT, 'H' or with a red/orange label.
- Suitable isolating valves (complying with Water Regulations and Bylaws) **MUST** be fitted on the hot and cold water supplies to the shower as an independent means of isolating the water supplies should maintenance or servicing be necessary position as close as is practicable to the water supply inlets of the mixer shower; position as close as is practicable to the water supply inlets of the mixer shower. If this isolator is fitted in a loft space, the loft must have a fixed access ladder and be boarded, with appropriate lighting from the access point to the isolator.
- It is preferable to flush the pipework to clear the system of debris and check for leaks before connecting to the mixer.
- The mixer inlets contain removable filters that may become blocked if debris is not flushed through before fitting.

Commercial Applications

- It is recommended that for all commercial applications, easily accessible, in-line filters are used to aid maintenance.

Hard Water Areas

- a. If it is intended to operate the shower in areas of hard water (above 200-ppm temporary hardness), a scale inhibitor may have to be fitted. For advice on the scale inhibitor, please contact Customer Experience.
- b. For best performance the shower head **MUST** be regularly cleaned to remove scale and debris.

WATER SYSTEM REQUIREMENTS

This mixer shower is suitable for:

- Gravity water systems
- Pumped gravity systems
- Fully modulating type combination boilers
- Multi-point hot water heaters
- Thermal storage
- Unvented systems

When installing this mixer with a combination or multi-point boiler, it may be necessary to install flow regulation.

Check that the appliance is capable of delivering hot water at a minimum switch-on flow rate of 3 litres per minute. At flow rates between 3 and 8 litres per minute, the appliance **MUST** be capable of raising the water temperature to 52°C minimum.

Water temperature at the inlet of the mixer valve **MUST** remain relatively constant when flow rate adjustments are made - refer to the appliance operating manual to confirm compatibility with this mixer shower.

Where thermal store systems and instantaneous gas water heaters are used, if excessive draw-off takes place, the appliance may not be able to maintain an adequate output temperature. This could result in the shower temperature becoming noticeably cooler.

Flow regulators can be fitted with high-pressure water systems to reduce flow rate and assist economy.

The hot supply temperature **MUST** remain a minimum of 10°C hotter than the required blend temperature for optimum performance.

***Fig.2**

*Diagrammatic view – not to scale.
For illustration purposes only.

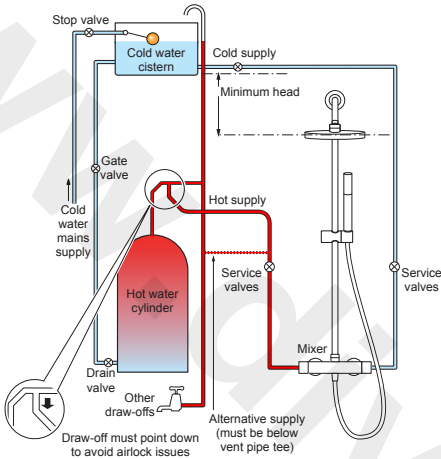

TYPICAL DOMESTIC INSTALLATIONS Domestic Gravity Fed Systems (fig.2)

The mixer shower **MUST** be fed from a cold water cistern and hot water cylinder providing nominally equal pressures. There **MUST** be a minimum of one metre head of water. The minimum head distance is measured from the base of the cold water cistern to top of the shower head.

If valves are gravity fed then supply pressure should be verified to ensure conditions of use are appropriate for the valve.

***Fig.3**

*Diagrammatic view – not to scale.
For illustration purposes only.

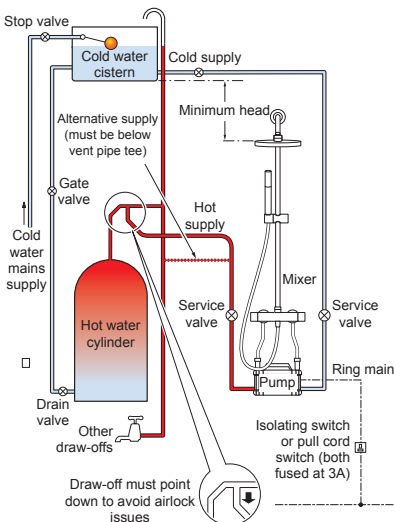

Pumped Gravity Fed Systems (fig.3)

The mixer shower **MUST** be fed from a cold water cistern and hot water cylinder providing nominally equal pressures.

The mixer shower may be used with a gravity fed system with a pump to boost pressures as shown; please refer to the pump installation guide to establish the minimum head requirements for automatic operation of the pump.

Thermostatic bar mixer shower

Instantaneous Gas-heated Systems, e.g. combination boilers (fig.4)

The mixer shower **MUST** be installed with a multi-point gas water heater or combination boiler of a fully modulating design i.e. to maintain relatively stable hot water temperatures.

A drop tight pressure reducing valve **MUST** be fitted if the supply pressures exceed 5 bar running.

An expansion vessel **MAY** be fitted, and regularly maintained, to prevent the mixer shower being damaged by excess pressures. This may already be installed within the boiler (check with manufacturer) and is in addition to the normally larger central heating expansion vessel.

*Fig.4

*Diagrammatic view – not to scale. For illustration purposes only.

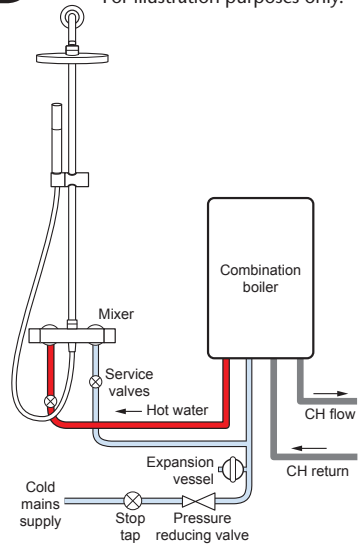

Unvented Mains Pressure Systems (fig.5)

The mixer shower can be installed with an unvented, stored hot water cylinder.

For systems with no cold water take off after the appliance reducing valve, it will be necessary to fit an additional drop tight pressure reducing valve when the mains pressure is over 5 bar. The drop tight pressure reducing valve **MUST** be set at the same value as the unvented package pressure reducing valve.

NOTE: An additional expansion vessel may be required if a second pressure reducing valve is installed. This does not apply to packages with a cold take off after the pressure reducing valve to the cylinder.

*Fig.5

*Diagrammatic view – not to scale. For illustration purposes only.

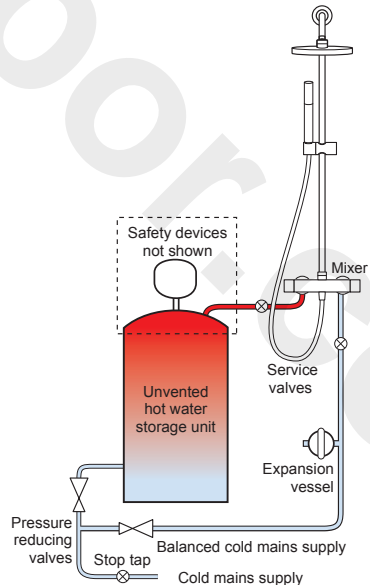

***Fig.6**

*Diagrammatic view – not to scale.
For illustration purposes only.

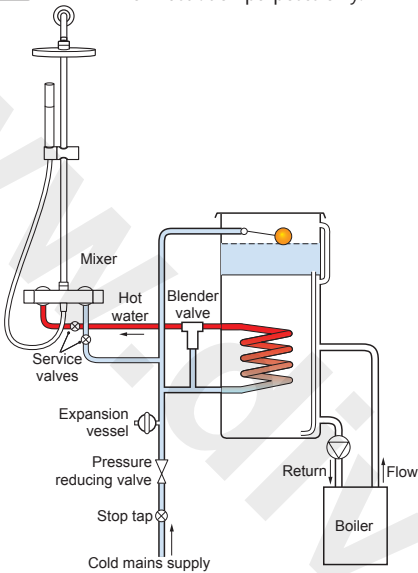

Mains Pressurised Thermal Store Systems (fig.6)

Packages of this type, fitted with a tempering valve (blender valve) can be used. A drop tight pressure reducing valve **MUST** be fitted if the supply pressures exceed 5 bar running.

An expansion vessel **MUST** be fitted and regularly maintained, to ensure the unit is not damaged by excess pressures. This may already be installed externally or internally within the thermal store (check with thermal store manufacturer).

INSTALLATION

PREPARING THE SHOWER

Check the contents to make sure all items are present.

Before starting, make sure all of the openings on the valve are carefully covered to stop ingress of any debris etc. while routing the supply pipework.

The shower valve is suitable for exposed installation onto solid wall, a stud partition wall, dry lined wall or fixing to a laminate cubicle or panel.

SITING OF THE SHOWER & ACCESSORIES

Refer to **fig.7** for correct siting of the shower.

The mixer shower should be positioned as detailed, with all controls within comfortable reach of the user.

The handset can be positioned on either side of the riser rail pipe.

The valve must be installed in a position that allows for easy access for future maintenance and commissioning.

PUSH FIT BRACKET

If the product has been supplied with the push fit bracket (**fig.8**), please follow the fitting instructions supplied with it.

***Fig.7**

*Diagrammatic view – not to scale.
For illustration purposes only.

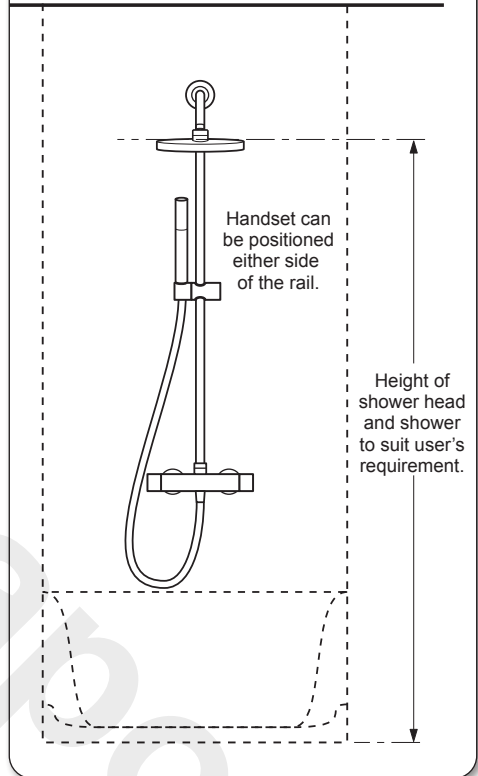

Fig.8

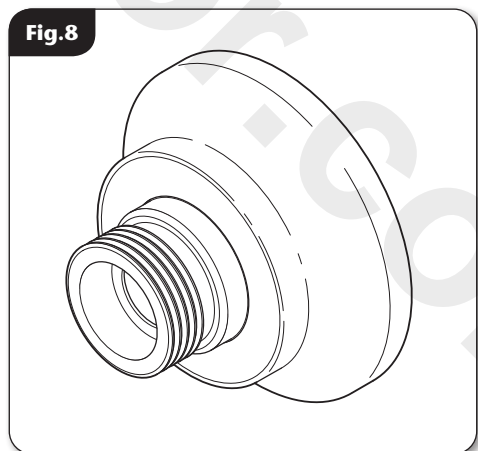
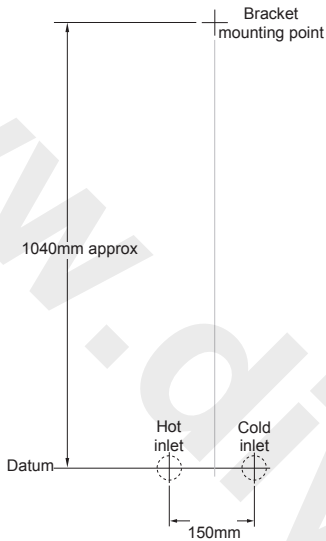

Fig.9



FITTING THE RISER PIPE/FIXED HEAD

Mark the centre hole for the fixed head mounting bracket at a height of approximately 1040mm from the inlet datum (**fig.9**).

IMPORTANT: All dimensions listed in this fitting book regarding the product and installation are approximate.

NOTE: The elongated hole in the mounting bracket allows for a small amount of adjustment.

Drill and plug the wall. An appropriate drill bit should be used. If the wall is brick, plasterboard or a soft building block, appropriate wall plugs and screws should be fitted.

Secure the arm mounting plate to the wall.

Fig.10

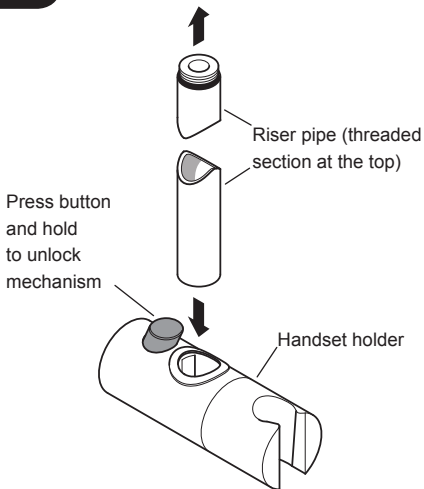

If the handset holder is required, depress the button on the handset holder (**fig.10**), slide the holder onto the pipe. The threaded section of the riser pipe should be at the top.

Screw the fixed shower head arm to the top of the riser pipe.

NOTE: If the mixer shower is supplied with the fixed riser kit and the kit is to be used, it will be necessary to remove the outlet adapter and replace it with the collar and adapter assembly supplied with the riser kit.

Thermostatic bar mixer shower

Install the adaptor into the top outlet of the mixer shower. Slide the base of the riser pipe into the adaptor (**fig.11**), making sure the sealing washer and locking collar are in place. Do not fully tighten the collar at this time.

Fit the rear section of the fixed arm over the mounting plate, but do not fully tighten the grub screw at this time (**fig.12**).

Adjust the riser pipe and fixed arm position to suit.

Once correctly positioned, lock the diverter collar. Finger tight should be sufficient.

NOTE: There is a small amount of depth adjustment within the collar. Adjust the depth of the bracket before securing in place to the mounting plate.

Using a suitable allen key, secure the fixed arm in place by tightening the locking screw.

LEAK TESTING

IMPORTANT: Flush out the pipework in accordance with Water Regulations and Bylaws.

Fit the hose to the outlet without the shower head fitted and direct it towards the waste outlet.

Open the water isolating valves to the shower and check for leaks.

If any leaks are found, rectify them before carrying out the commissioning procedure.

Fitting the Fixed Shower Head

Screw the fixed head to the fixed spray arm. Make sure the sealing washer is in place and screw tight to seal the joint.

Fitting the Hose and Handset

Connect one end of the flexible hose to the bottom outlet connector on the mixer shower and the other end to the handset, making sure that the seals are in place.

IMPORTANT: It is the conical end of the hose which grips into the holder. The handset will not fit in the holder without the hose attached.

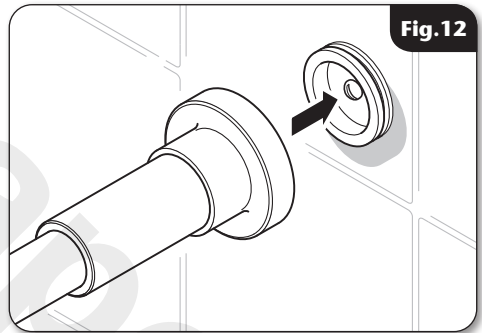
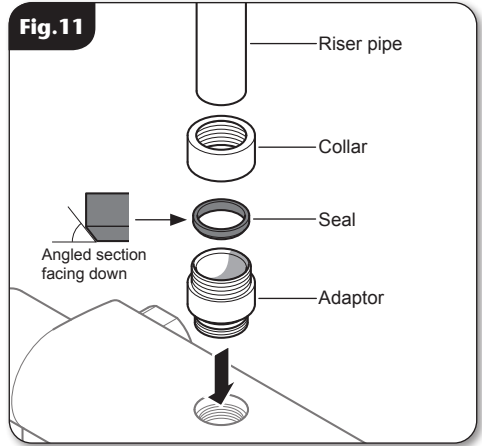

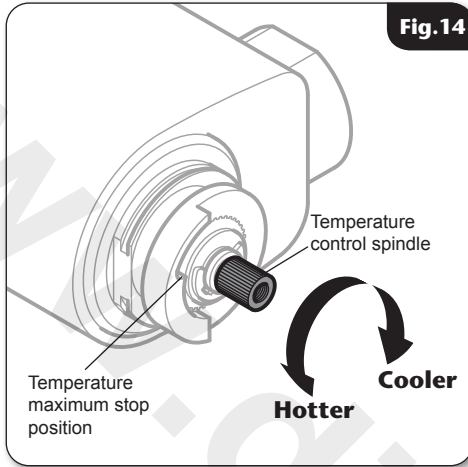

COMMISSIONING

Start the water flow by rotating the diverter control spindle (left hand side) clockwise for the fixed shower head or anti-clockwise for the handset.

Make sure that the hot and cold water supplies are fully open and at (or near to) their design temperature and pressures, and are within the requirements as stated on **page 2**.

Allow the shower to run until the water temperature has stabilised.

Rotate the temperature control spindle (**fig. 14**) until your maximum showering temperature is reached.

FITTING THE CONTROLS

The mixer shower is supplied without the handle controls fitted. Once a comfortable showering temperature has been established, turn the shower off using the diverter control (6 o'clock position). Fit the handles as shown in **figs. 14, 15a & 15b**.

IMPORTANT: DO NOT over tighten fitting screws.

Fit the temperature control, making sure the maximum temperature stop pin is as close to the flat edge of the temperature stop as possible.

(**figs. 14 & 15a**). Secure the temperature control in place with the retaining screw and fit the screw cap. **DO NOT over tighten.**

Fit the diverter control so that the lever is in a 6 o'clock position. Secure the flow handle in place with the retaining screw and fit the screw cap. **DO NOT over tighten.**

REMOVING THE HANDLES FOR MAINTENANCE

Remove the lever cap from the temperature control to allow access to the retaining screw. Remove the retaining screw and pull the temperature control off (**figs. 15a & 15b**).

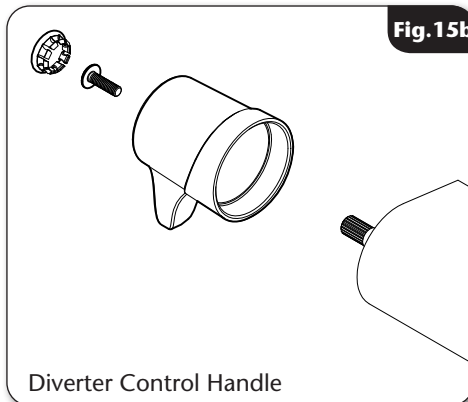
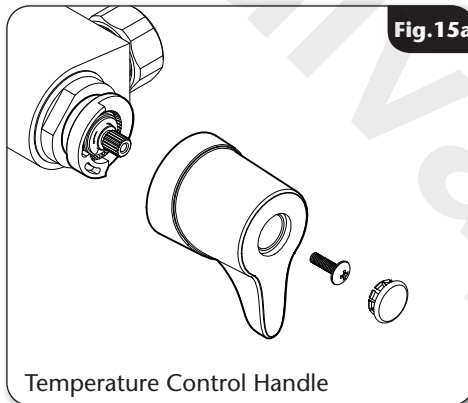

TEMPERATURE ADJUSTMENT RANGE

The mixer shower has a temperature stop to prevent accidental rotation to higher temperatures. This is adjustable to provide a maximum temperature of 35°C – 45°C.

The mixed water temperature can be adjusted from cold through to a top limit (which can be pre-set during installation).

Recommended Outlet Temperatures

The **BuildCert TMV** scheme recommends the following set maximum mixed water outlet temperatures for use in all premises:

44°C - for bath fill but see notes below.

41°C - for showers.

41°C - for washbasins.

38°C - for bidets.

The mixed water temperatures must never exceed **46°C** at terminal fitting.

The British Burns Association recommends **37°C** to **37.5°C** as a comfortable bathing temperature for children. In premises covered by the Care Standards Act 2000, the maximum mixed water outlet temperature is **43°C**.

ADJUSTING THE MAXIMUM TEMPERATURE STOP SETTING

The maximum temperature stop **SHOULD NOT** need to be removed. Correct position shown in **fig 16**.

Turn the flow control (left hand side) to full flow. With a steady flow running, adjust the temperature spindle until the temperature is to your maximum showering temperature (**fig.14**).

When the showering temperature is satisfactory turn off the shower. Refit the temperature control as shown in **fig.15a**.

Secure the temperature control in place with the screw and refit the lever cap.

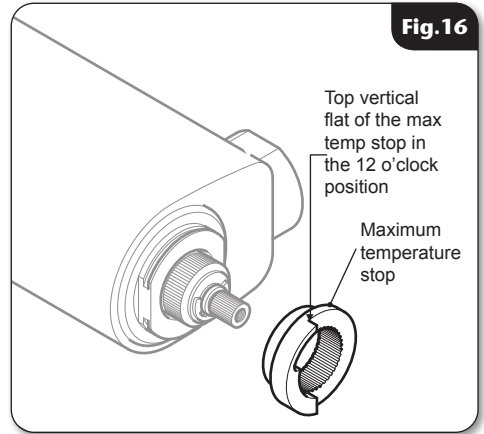
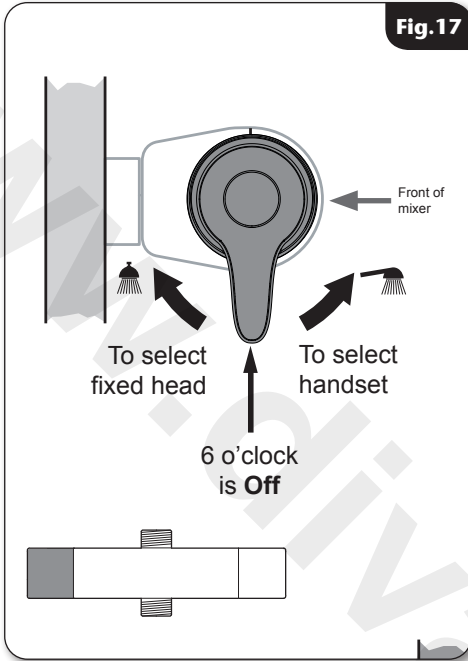

Fig.16

Fig.17



OPERATING THE SHOWER (Diverter)

When the **ON/OFF** diverter control lever is at **6 o'clock**, it is in the **OFF** position.

To use the **fixed head** outlet turn the diverter clockwise. To decrease the flow, turn the diverter control lever back towards the **OFF** setting (**fig.17**).

To use the **handset** turn the diverter control anti-clockwise. To decrease the flow, turn the diverter control lever back towards the **OFF** setting.

To stop the water flow, reposition the diverter control lever to the (6 o'clock) **OFF** position.

To adjust the water temperature, rotate the temperature control (right-hand side) clockwise for a **cooler** shower or anti-clockwise for a **hotter** shower (**fig.18**).

CAUTION: Exposed metal and chromed surfaces may become hot during use.

Fig.18

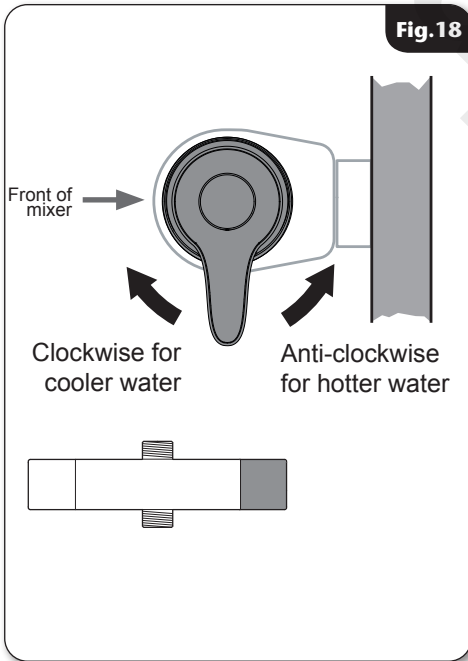

TMV2 REQUIREMENTS (12 MONTHLY VERIFICATION)

It is a requirement that all TMV2 approved valves shall be verified against the original set temperature results once a year.

On installation and on a yearly basis please perform the following checks:

1. Cold water supply isolation test

Isolating the cold water supply to the TMV, wait for five seconds if water is still flowing check that the temperature is below **46°C**.

If there is no significant change to the set outlet temperature ($\pm 2^{\circ}\text{C}$ or less change from the original settings) and the fail-safe shut off is functioning, then the valve is working correctly and no further service work is required.

If there is a residual flow during the commissioning or the annual check this is acceptable providing the temperature of the water seeping from the valve is no more than **2°C** above the designated maximum mixed water outlet temperature setting of the valve.

NOTE:

Temperature readings should be taken at the normal flow rate after allowing for the system to stabilise. The sensing part of the thermometer probe must be fully submerged in the water that is to be tested.

PRODUCT FLOW RATES - For guidance only

| | | | | | | | | | | |
|----------------|-----|-----|-----|-----|-----|------|------|------|------|------|
| Flow rate l/m | 3.5 | 5.5 | 7.0 | 8.5 | 9.5 | 14.0 | 20.0 | 25.0 | 28.5 | 31.5 |
| Pressure (bar) | 0.1 | 0.2 | 0.3 | 0.4 | 0.5 | 1.0 | 2.0 | 3.0 | 4.0 | 5.0 |

Conditions for test

Inlet temperatures comply with EN1111 requirements.

Outlet Temperatures 38°C.

Flow Control open.

Open outlet - No hose or shower head connected.

MAINTENANCE

The following maintenance procedure must be carried out for commercial and health care premises, but is not necessarily required for domestic installations.

Maintenance of the unit is required to give continued performance after installation and that it continues to provide scald prevention.

NOTE: A thermostatic mixing valve in need of maintenance can be undetectable in normal use and only becomes apparent when a disruption occurs in the hot or cold water supply temperatures or pressures.

The frequency of routine maintenance of the internal of the valve will depend mainly on the water supply condition. Experience of local conditions will dictate the intervals for inspection and in-service testing - guidance has been given below which can be adjusted for local requirements.

- a) Initially check the filters for debris once every three months and clean if necessary.
- b) Perform a thermal shut off test every three months and check the maximum temperature setting. See the Commissioning section for the details of this test and readjustment of the maximum temperature setting if required.
- c) If the maximum water temperature varies by more than 2°C from the commissioned setting then carry out the following checks
 - Check the isolating valves are fully open.
 - Check the internal surface for scaling.

If the body requires descaling then it should be removed from the pipework to carry out this work - all rubber parts **MUST** be removed before descaling.

- Check the function of the non-return valves.

The non-return valves (NRVs) prevent cross-flow between hot and cold supplies under unequal pressure conditions. They are designed for long life with no maintenance.

NOTE: The NRV's will only operate in one direction - water should be able to flow into the unit from the inlets, but NOT back out through the inlets.

If these checks do not highlight the reason for the temperature variation, then internal components will require replacement - please contact Customer Experience.

Cleaning

It is recommended that all products are cleaned using warm, soapy water.

Do not use abrasive or aggressive chemical cleaning products as this may affect the product surface finish and invalidate your guarantee.

Cleaning the Filters (fig.A)

It is advised that this should be carried out by a qualified person.

- Turn off the water supplies before starting.
- To gain access to the filters remove the unit from the inlet fittings.
- Remove the filter housing and disassemble.
- Wash the filters thoroughly under running water, use a suitable brush to remove all debris.
- Reassemble and fit in reverse order.

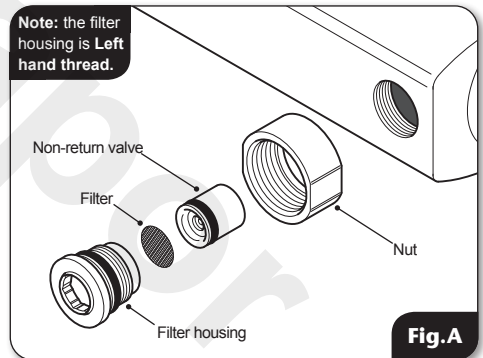

Disinfection

Where chlorine is used for the disinfection of water systems all relevant guidelines and approved codes of practice must be strictly followed. Failure to comply with the relevant guidelines and approved codes of practice may invalidate your guarantee.

WARNING!

DO NOT use powerful abrasive or solvent cleaning fluids when cleaning the shower as they may damage the fittings.

Thermostatic bar mixer shower

FAULT FINDING

The following can be carried out by a competent person

| Problem | Cause | Action |
|--------------------------|---|---|
| 1 Water too hot. | 1.1 Temperature control incorrectly commissioned. | 1.1.1 Refer to the Commissioning section. |
| | 1.2 Not enough cold water flowing through shower. | 1.2.1 Reposition temperature control knob |
| | 1.3 Increase in the ambient cold water temperature. | 1.3.1 Reposition temperature control knob. |
| | 1.4 Cold water supply blocked. | 1.4.1 Turn off the shower and consult a competent plumber or contact Customer Experience. |
| | 1.5 High volume of cold water drawn off elsewhere. | 1.5.1 Reduce the simultaneous demand from the supply. |
| 2 Water too cold. | 2.1 Temperature control incorrectly commissioned. | 2.1.1 Refer to the Commissioning section. |
| | 2.2 Not enough hot water flowing through shower. | 2.2.1 Reposition temperature control knob |
| | 2.3 Decrease in the ambient cold water temperature. | 2.3.1 Reposition temperature control knob |
| | 2.4 Insufficient hot water supplies from the heating system. | 2.4.1 Make sure heating appliance is set to maximum or has sufficient stored hot water. 2.4.2 Make sure heating appliance is igniting by trying a hot water tap elsewhere. |
| | 2.5 Hot water supply blocked or restricted. | 2.5.1 Turn off shower and consult a competent plumber or contact Customer Experience. |
| | | |

Thermostatic bar mixer shower

FAULT FINDING

| <i>Problem</i> | <i>Cause</i> | <i>Action</i> |
|--|---|--|
| 3 Water does not flow or shower pattern collapses when another outlet is turned on. | 3.1 Water supplies cut off. | 3.1.1 Check water elsewhere in house and if necessary contact local water company. |
| | 3.2 Shower unit blocked. | 3.2.1 Inspect the inlet filters. Clean if necessary. |
| | 3.3 Blockage in pipework. | 3.3.1 Turn off the shower and consult a suitably competent plumber. |
| | 3.4 Shower head blocked. | 3.4.1 Clean shower head. |
| | 3.5 System not capable of supplying multiple outlets at the same time. | 3.5.1 Reduce the simultaneous demand. 3.5.2 Make sure stop/service valves are fully open. 3.5.3 Check if sufficient water pressure. |

The following is recommended for a professional qualified installer only

| | | |
|--|---|---|
| 4 Water too cold. | 4.1 Running pressure in excess of maximum recommended. | 4.1.1 Fit a pressure reducing valve. |
| 5 Shower controls noisy while in use. | 5.1 Running pressure in excess of maximum recommended. | 5.1.1 Fit a pressure reducing valve. |
| 6 Shower will not shut off. | 6.1 Flow control cartridge worn. | 6.1.1 Renew flow control cartridge. |

www.divapor.com

UK SERVICE POLICY

In the event of a product fault or complaint occurring, the following procedure should be followed:

DO NOT REMOVE THE PRODUCT

1. Telephone Customer Experience on **024 7637 2222** having available your details including post code, the model number and power rating of the product, together with the date of purchase and, where applicable, details of the particular fault.
2. If required, the Customer Experience Advisor will arrange for a qualified engineer to call.
3. All products attended to by a Triton service engineer must be installed in full accordance with the Triton installation guide applicable to the product. Every product pack contains an installation guide, however, they can also be downloaded free at www.tritonshowers.co.uk.
4. Our engineer will require local parking and if a permit is required, this must be available to the engineer on arrival at the call.
5. If loft access is required for isolation or to complete a repair, the loft must have a fixed access ladder and be boarded, with appropriate lighting from the access point to and around the repair area.
6. It is essential that you or an appointed representative (who must be over 18 years of age) is present for the duration of the service engineer's visit. If the product is in guarantee you must produce proof of purchase.
7. Where a call under the terms of guarantee has been booked and the failure is not product related (i.e. scaling and furring, incorrect water pressure, pressure relief device operation or electrical/plumbing installation fault) a charge will be made. A charge will also be issued if nobody is at the property when the service engineer calls or adequate parking/permit is not available.
8. If the product is no longer covered by the guarantee an up-front fixed fee will be charged before the site visit.
9. Your receipt must be retained as proof of purchase. Should proof of purchase not be available on an 'in-guarantee' call, or should the service engineer find that the product is no longer under guarantee, the engineer will charge the same fixed price and will request payment prior to departing. If payment is not made on the day an administration charge will be added to the fixed charge.
10. If a debt is outstanding from a previous visit, or from any other Triton purchase, Triton reserves the right to withhold service until the debt has been settled.
11. Triton takes the health, safety and wellbeing of its employees very seriously and expects customers to treat all staff members with respect. Should any employee feel threatened or receive abuse, either verbally or physically, Triton reserves the right to withhold service.

Replacement Parts Policy

In line with AMDEA guidelines, Triton retains functional spares for as long as there is a market for them and in most cases, well beyond. Due to the vast array of product types, the life cycle of products can vary and therefore so can the length of time parts can be supplied. Spare parts can be ordered via our online spare parts store or by telephoning our Triton Customer Experience team on **024 7637 2222**. Payment should be made by credit / debit card (excluding American Express or Diners Card). Payment can also be made by pre-payment of a pro-forma invoice, by cheque or postal order.

Telephone orders are based on information given during the call. Before contacting Triton, please verify your requirements using the information contained in the user guide. Triton cannot accept liability for incorrect part identification.

Triton Showers
Triton Road
Nuneaton
Warwickshire, CV11 4NR

Triton is a division of Norcros Group (Holdings) Limited

Triton reserve the right to change product specification without prior notice. E&OE. © TRITON SHOWERS 2021

TRITON UK STANDARD GUARANTEE

This guarantee applies only to products installed within the United Kingdom and does not apply to products used expressly for commercial gain, unless this use has been specified by Triton. This guarantee does not affect your statutory rights.

With the exception of accessories, Triton guarantee the product against all manufacturing defects for a period of **5 years** for use in a domestic environment from the date of purchase, provided that it has been installed by a competent person in full accordance with the fitting instructions.

All accessories such as shower heads, hoses and riser rails carry a **1 year** parts only guarantee against manufacturing defects.

Any part found to be defective during this guarantee period we undertake to repair or replace at our option without charge, so long as it has been properly maintained and operated in accordance with the instructions and has not been subject to misuse or damage or the effects of limescale build up. This product must not be taken apart, modified or repaired except by a person authorised by Triton.

What is not covered:

1. Breakdown due to:
 - a) use other than domestic use by the property occupants;
 - b) wilful act or neglect;
 - c) any malfunction resulting from the incorrect use or quality of electricity, gas or water or incorrect setting of controls;
 - d) failure to install in accordance with this installation guide.
2. Claims for missing parts once the product has been installed.
3. Repair costs for damage caused by foreign objects or substances.
4. Total loss of the product due to non-availability of parts.
5. Compensation for loss of use of the product or consequential loss of any kind.
6. Call out charges due to an abortive visit or where no fault has been found with the appliance.
7. The cost of repair or replacement of isolating switches, electrical cable, fuses and/or circuit breakers or any other accessories installed at the same time. Replacement of the Pressure Relief Device that only activates when the shower outlet is blocked is also excluded.
8. The cost of routine maintenance, adjustments, overhaul modifications or loss or damage arising therefrom, including the cost of repairing damage, breakdown, malfunction caused by corrosion, furring, frost or exposure to freezing conditions.
9. Call out charges where the water supply cannot be isolated, this includes consequential losses arising from unserviceable supply valves, or inaccessible product or valves located in a loft space without suitable access.

For the latest Terms & Conditions please see:

www.tritonshowers.co.uk/terms

PLEASE NOTE PRODUCT REGISTRATION IS ONLY AVAILABLE TO UNITS PURCHASED & INSTALLED IN THE UK

Customer Experience: 024 7637 2222

Trade Installer Hotline: 024 7637 8344

www.tritonshowers.co.uk

E-mail: serviceenquiries@tritonshowers.co.uk

E-mail: technical@tritonshowers.co.uk