

**TRITON**

**86005350 BASIN MIXER**

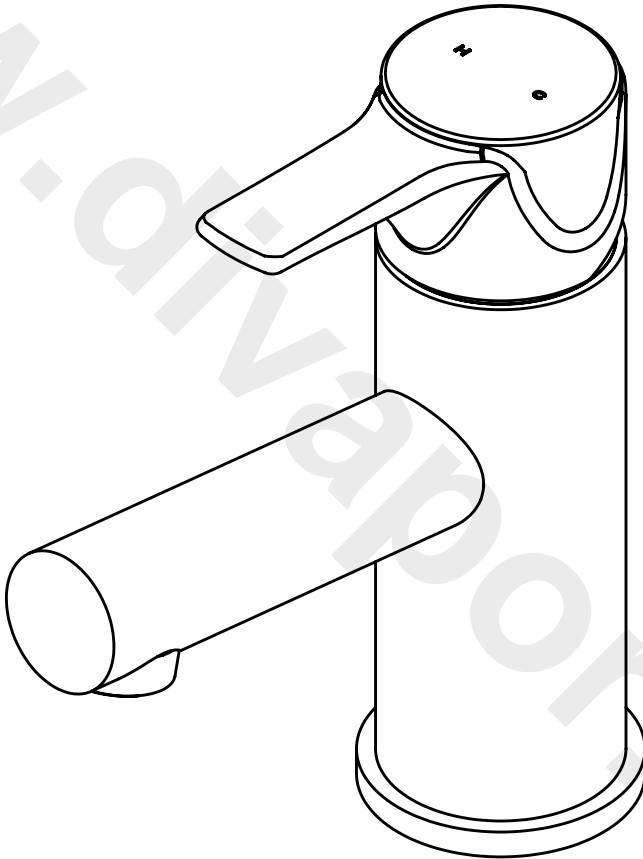

**Installation and  
operating instructions**

2181422C - February 2021

<b>CONTENTS</b>	<b>Page</b>
DIMENSIONS .....	1
MAIN COMPONENTS.....	1
INTRODUCTION.....	2
INSTALLATION.....	3 - 4
SPARE PARTS .....	5
GUARANTEE, SERVICE POLICY, ETC. ....	REAR COVER

**INSTALLERS PLEASE NOTE**

- THESE INSTRUCTIONS ARE TO BE LEFT WITH THE USER
- ALL DIMENSIONS LISTED IN THIS FITTING BOOK REGARDING THE PRODUCT AND INSTALLATION ARE APPROXIMATE.
- TO CHECK THE PRODUCT SUITABILITY FOR COMMERCIAL AND MULTIPLE INSTALLATIONS, PLEASE CONTACT TRITON'S SPECIFICATION ADVISORY SERVICE BEFORE INSTALLING. PLEASE SEE BACK OF BOOK FOR CONTACT INFORMATION.



## **INTRODUCTION**

This guide contains all the necessary fitting instructions for your basin mixer. Please read this guide carefully before beginning your installation.

Care taken during the installation will provide a long life and trouble free operation from your tap.

## **COMPONENTS**

Check that all components are correct. The box contains:

- Mixer x1
- Fixing Kit x1
- Flexible pipe x1
- Click Waste x1

## **SITE REQUIREMENTS**

The installation must be in accordance with water supply (water fittings) regulation 1999 and/or local Bylaws.

Before installing taps flush all pipework to remove debris.

Maximum static pressure:	10 Bar
Running Pressure::	0.2 to 5.0 Bar

This mixer is designed for high pressure systems found in the UK, but can be installed with low pressure gravity water systems with reduced flow rates.

This mixer is suitable for all water pressures and should be fitted in accordance with Water Regulations.

For effective operation of the internal seals, the maximum static pressure must not be exceeded.

## **FLOW RATE**

Basin Tap:

Flow Rate 3.0 Bar	23 l/min
-------------------	----------

## **CLEANING**

Triton recommends that all products are cleaned using warm, soapy water.

Do not use abrasive or aggressive chemical cleaning products as this may affect the product surface finish and invalidate your guarantee.

### INSTALLATION - BASIN MIXER

Before starting the installation check that all components are present.

#### IMPORTANT

DO NOT choose a position where the tap could become frozen.

#### ASSEMBLY

Connect the hot and cold supplies to the mixer using the braided hoses supplied, hot on left as shown in fig 1.

Fit the mixer into the basin (fig.2).

Secure the mixer in position using the stud, seal and horse shoe plate.

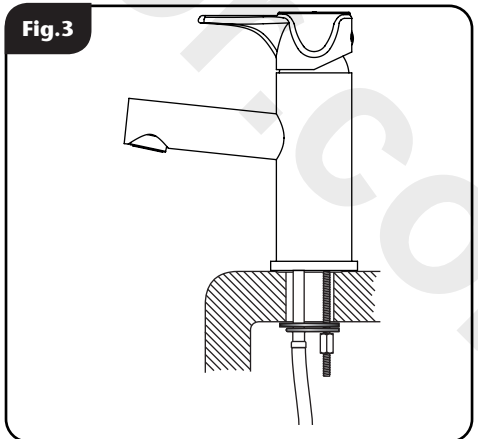
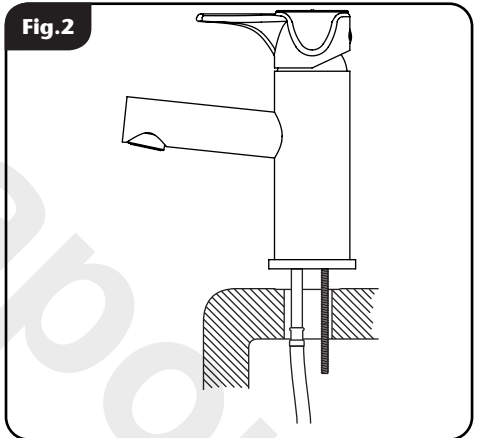
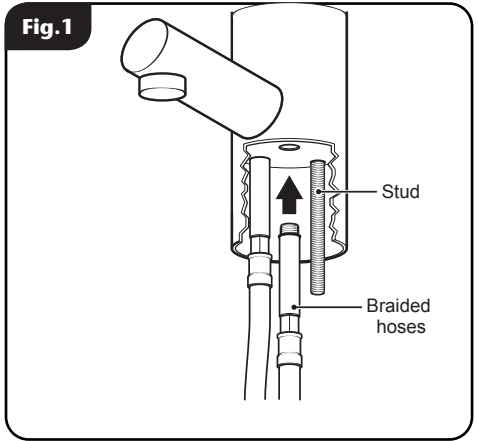
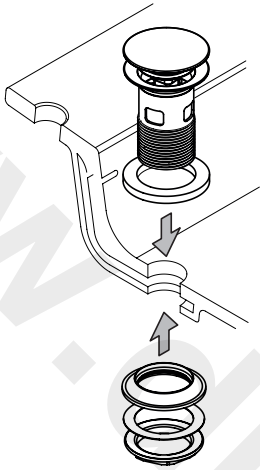

Fig.3



### INSTALLATION - SLOTTED CLICK WASTE

Before starting the installation check that all components are present.

### ASSEMBLY

Remove the retaining nut and base seals from the slotted waste and push the waste through the hole in the basin.

Re-fit the seals and secure the waste with the retaining nut (fig 3).

### OPERATING CLICK WASTE

The click waste operates by pressing the chrome cap; push to close and push to open.

### LEAK TESTING

Switch on the supplies at the mains. Turn the tap on and test for leaks in the pipe connections and waste. Remedy if required.

**SPARE PARTS**

Replacement parts can be ordered from Triton Customer Experience.

**Basin Tap**

**Ref. Description Part number**

- 1 – Handle / Trims Pack.....83316410
- 2 – Flow Control Cartridge.....83316330
- 3 – Fixing Pack .....83316340
- 4 – Flow Straightener .....83316360
- 5 – Flexible Pipes.....83316480
- 6 – Click Waste.....83316470

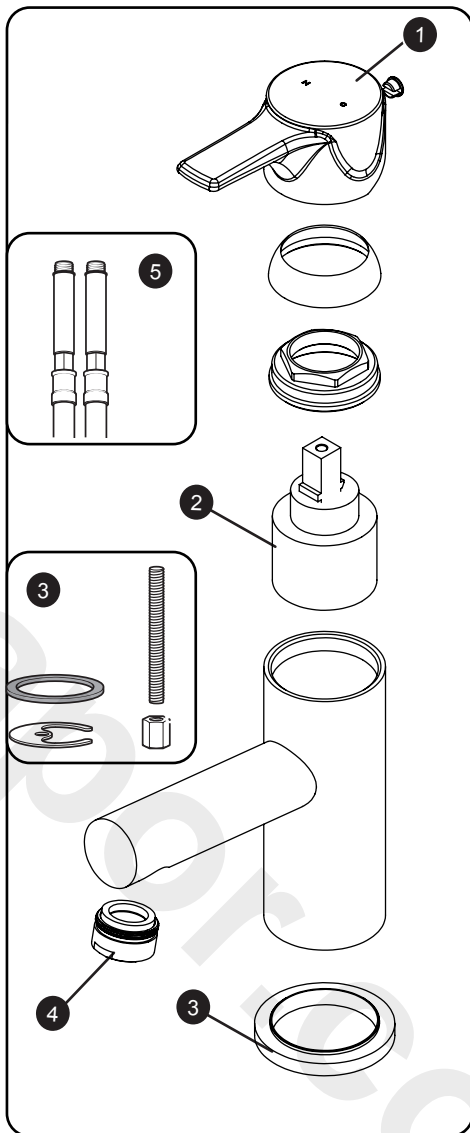

To check the product suitability for commercial and multiple installations, please contact Triton's specification advisory service before installation.

Telephone: 024 7637 2222

E mail: [technical@tritonshowers.co.uk](mailto:technical@tritonshowers.co.uk)

## UK SERVICE POLICY

In the event of a product fault or complaint occurring, the following procedure should be followed:

1. Telephone Customer Experience having available, your details including post code and the model number together with the date of purchase and, where applicable, details of the particular fault.
2. If required, the Customer Experience Advisor will arrange for a replacement part or product to be sent.
3. If the product is no longer covered by the guarantee, contact Triton for advice.
4. Should proof of purchase not be available the customer may be expected to pay for any parts or repair.
5. If a debt is outstanding from a previous visit, or from any other Triton purchase, Triton reserves the right to withhold service or supply of replacement parts until this debt has been settled.
6. Triton takes the health, safety and wellbeing of its employees very seriously and expects customers to treat all staff members with respect. Should any employee feel threatened or receive abuse, either verbally or physically, Triton reserves the right to withhold service.

### Replacement Parts Policy

Availability: It is the policy of the manufacturer to maintain parts availability for the duration of production and a period of two years thereafter

Spare parts are available via our website [www.tritonshowers.co.uk](http://www.tritonshowers.co.uk) or by telephoning Triton Customer Experience.

Payment should be made by credit/debit card (excluding American Express or Diners Card). Payment can also be made by pre-payment of a pro forma invoice by cheque or money order. Telephone orders are based on information given during of the call.

Before contacting Triton, please verify your requirements using the information contained in the user guide. Triton cannot accept liability for incorrect part identification.

## TRITON UK STANDARD GUARANTEE

This guarantee applies only to products installed within the United Kingdom and does not apply to products used commercially. This guarantee does not affect your statutory rights.

Triton guarantee the product against all manufacturing defects for a period of 5 years for domestic use only, from the date of purchase, provided that it has been installed by a competent person in full accordance with the fitting instructions.

Any part found to be defective during this guarantee period we undertake to repair or replace at our option without charge so long as it has been properly maintained and operated in accordance with the instructions, and has not been subject to misuse, damage or the effects of limescale build up. This product must not be taken apart, modified or repaired except by a person authorised by Triton.

### What is not covered:

1. Breakdown due to:
  - a) use other than domestic use by the property occupants;
  - b) wilful act or neglect;
  - c) any malfunction resulting from the incorrect use or quality of water or incorrect setting of controls;
  - d) failure to install in accordance with this installation guide.
2. Claims for missing components once the product has been installed.
3. Repair costs for damage caused by foreign objects or substances.
4. Total loss of the product due to non-availability of parts.
5. Compensation for loss of use of the product or consequential loss of any kind.
6. The cost of routine maintenance, adjustments, overhaul modifications or loss or damage arising therefrom, including the cost of repairing damage, breakdown, malfunction caused by corrosion, furring, or limescale build up.
7. Charges where the water supply cannot be isolated, this includes consequential losses arising from unserviceable supply valves.

For the latest Terms & Conditions, please see: [www.tritonshowers.co.uk](http://www.tritonshowers.co.uk)

Triton Showers

Triton Road

Nuneaton

Warwickshire CV11 4NR

Triton is a division of Norcrox Group (Holdings) Limited

Customer Experience: 024 7637 2222

Trade Installer Hotline: 024 7637 8344

E-mail: [serviceenquiries@tritonshowers.co.uk](mailto:serviceenquiries@tritonshowers.co.uk)

TRITON reserve the right to change product specification without prior notice. E&OE.