

ISABEL

fixed showerhead

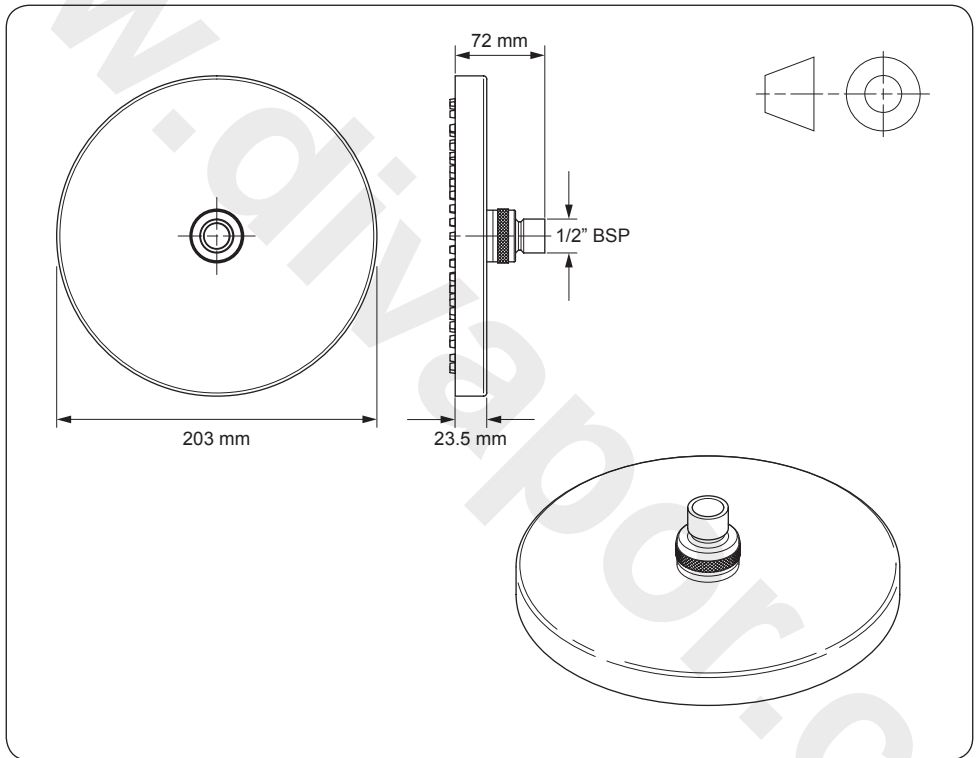

Installation Instructions

INSTALLERS PLEASE NOTE THESE INSTRUCTIONS ARE TO BE LEFT WITH THE USER

INTRODUCTION

Your shower is supplied with a single mode fixed showerhead, with a rub clean head.

CLEANING

WARNING!

Do not use abrasive or solvent cleaning fluids. The showerhead should be cleaned using a soft cloth and warm water.

Before cleaning, turn off the unit at the mains supply to avoid the shower being accidentally switched on.

IT IS IMPORTANT TO KEEP THE SHOWERHEAD CLEAN TO MAINTAIN THE PERFORMANCE OF THE SHOWER. The hardness of the water will determine the frequency of cleaning. For example, if the shower is used every day in a very hard water area, it may be necessary to clean the showerhead on a weekly basis.

To clean the nozzles simply rub your thumb over them.

DO NOT use a pin or similar to poke the holes otherwise the efficiency of the shower spray will be impaired.

In extreme cases, remove the showerhead and leave to soak overnight in a mild proprietary descaler. Make sure all traces of scale are removed and thoroughly rinse in clean water afterwards.

Before refitting the showerhead, flush any debris out of the arm.

SPARES

Ref.	Description	Part No.
1.	Fixed showerhead	88600010

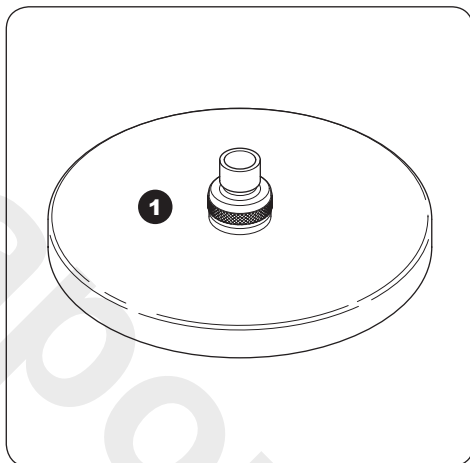

TRITON STANDARD GUARANTEE

Triton guarantee this product against defects arising from faulty workmanship or materials for a period of one year for domestic use only, from the date of purchase, provided that it has been installed by a competent person in full accordance with the fitting instructions.

Any part found to be defective during this guarantee period we undertake to repair or replace at our option without charge so long as it has been properly maintained and operated in accordance with the operating instructions, and has not been subject to misuse or damage.

This product must not be taken apart, modified or repaired except by a person authorised by Triton.

This guarantee applies only to products installed within the United Kingdom and does not apply to products used commercially. This guarantee does not affect your statutory rights.

Customer Service: ☎ 0844 980 0750

Trade Installer Hotline: ☎ 0844 980 0730

Fax: 0844 980 0744

www.tritonshowers.co.uk

E-mail: serviceenquiries@tritonshowers.co.uk

Triton Showers
Triton Road
Nuneaton
Warwickshire CV11 4NR

Triton is a division of Norcross Group (Holdings) Limited