

TRITON

POLONA *manual mixer shower*

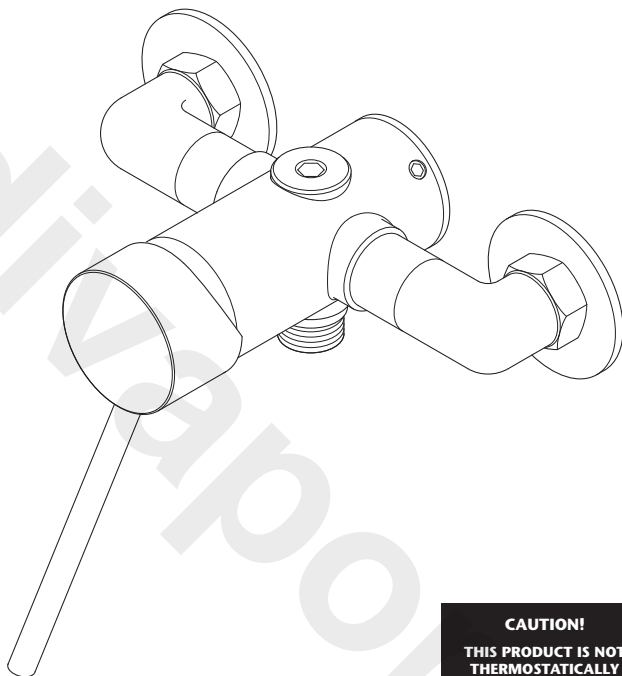

CAUTION!
THIS PRODUCT IS NOT
THERMOSTATICALLY
CONTROLLED

Installation and operating instructions

INSTALLERS PLEASE NOTE THESE INSTRUCTIONS ARE TO BE LEFT WITH THE USER

CONTENTS	Page
Main components	1
Introduction	2
Site requirements	2
Safety warnings	2
Plumbing requirements	3
Water system requirements	3
Typical suitable installations.....	4 - 5
Siting of the shower	6
Fitting the mixer.....	7
Bottom to top outlet change.....	8
Fitting to the wall	9
Fitting the control lever	9
Commissioning.....	10
Operating the shower.....	10
Cleaning.....	10
Flow chart	11
Dimensions.....	12
Spare parts	13
Fault finding	14
Guarantee, service policy, etc.	rear cover

To check the product suitability for commercial and multiple installations, please contact Triton's specification advisory service before installation.

Telephone: 0844 980 0730

Facsimile: 0844 980 0744

E mail: technical@tritonshowers.co.uk

MAIN COMPONENTS

Fig. 1

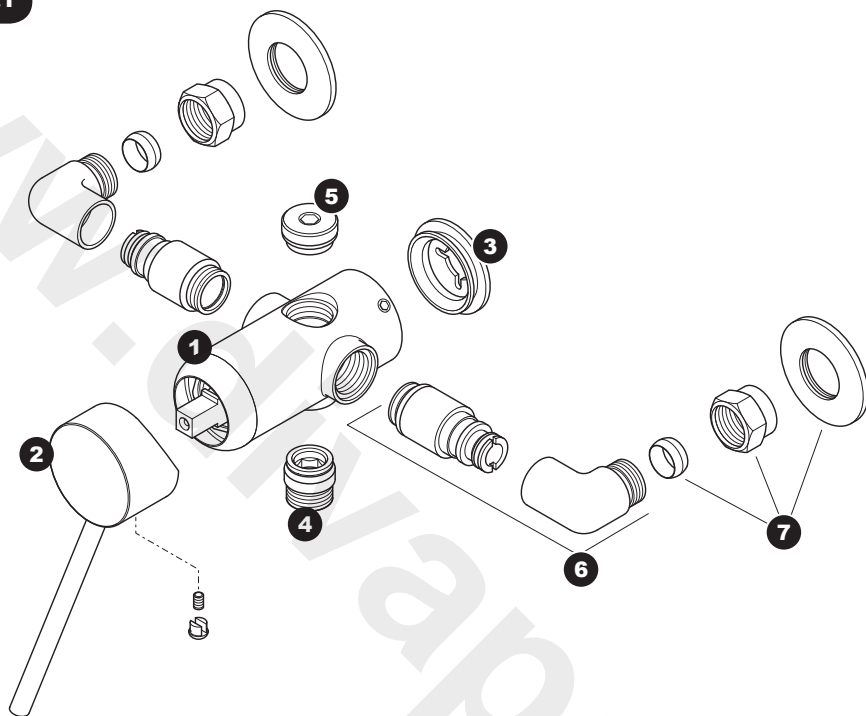

Ref. Description

1. Mixer shower body (*non thermostatic*)
2. Control handle
3. Fixing plinth
4. Outlet adaptor
5. Blanking plug
6. Elbows and fittings X2
7. Olive, nut, trim X2

All dimensions listed in this fitting book regarding the product and installation are approximate.

*All kits and fittings are for illustration purposes only and are not supplied unless otherwise stated.

INTRODUCTION

This book contains all the necessary fitting and operating instructions for your Triton mixer shower. Please read them carefully and read through the whole of this book before beginning your installation.

The shower installation must be carried out by a suitably competent person and in sequence of this instruction book.

Care taken during the installation will give a long and trouble free life from your mixer shower.

SITE REQUIREMENTS

The installation must be in accordance with Water Regulations and Bylaws.

Water pressure requirements

Running water pressure:

Gravity fed	- 0.1 bar min. 1.0 bar max.
Mains fed	- 1.0 bar min. 5.0 bar max.

Maximum static water pressure:

Gravity and mains	- 10 bar
-------------------	----------

This mixer shower is designed for use with traditional low pressure 'gravity' water systems, using a cold water cistern and hot water cylinder as well as for the higher pressure systems found in the UK up to a maximum of 5 bar running pressure.

For effective operation of the internal seals, the maximum static pressure must not be exceeded.

Pressure reducing valve

On sites where the running pressure is above 5 bar, the use of a suitably sized pressure reducing valve fitted in the cold mains supply pipe work can provide nominally equal pressures at the mixer shower.

Water minimum flow rate

For best performance within the specified running pressure range a minimum flow of 8 litres per minute should be available to both inlets.

Water temperature requirements

Maximum hot water temperature:	= 80°C
Recommended maximum:	= 65°C
Minimum hot water temperature:	= 52°C
Maximum cold water temperature:	= 20°C

The mixer shower MUST NOT be subjected to water temperatures above 80°C.

BS 6700 recommends that the temperature of stored water should never exceed 65°C.

A stored water temperature of 60°C is considered sufficient to meet all normal requirements and will minimise the effects of scale in hard water areas.

SAFETY WARNINGS

- DO NOT** choose a position where the shower could become frozen.
- DO NOT** connect this mixer shower to any form of tap or fitting not recommended by the manufacturer.
- DO NOT** allow the inlet pressure or flow rates to operate outside the guidelines laid out in 'site requirements'.
- DO NOT** connect the mixer shower to a gravity hot supply and a mains cold supply (or vice versa).

CAUTION!

**THIS PRODUCT IS NOT
THERMOSTATICALLY CONTROLLED**

Replacement parts can be ordered from Triton Customer Service. See 'spare parts' for details and part numbers.

PLUMBING REQUIREMENTS

DO NOT use jointing compounds on any pipe fittings for the installation.

DO NOT solder fittings near the mixer unit as heat can transfer along the pipework and damage the mixer valve.

IMPORTANT:

- The layout and sizing of pipework MUST be such that nominally equal inlet supply pressures are achieved and the effects of other draw-offs are minimised.
- The pipe-work should be installed such that other taps and appliances being operated elsewhere on the premises do not significantly affect the flow.
- When connecting pipe-work avoid using tight 90° elbows; swept or formed bends will give the best performance.
- The hot water pipe entry must be made to the left-hand side inlet, marked HOT, 'H' or with a red/orange label.
- Suitable isolating valves (complying with Water Regulations and Bylaws) must be fitted on the hot and cold water supplies to the shower as an independent means of isolating the water supplies should maintenance or servicing be necessary.
- It is preferable to flush the pipe-work to clear the system of debris and check for leaks before connecting to the mixer.

(Commercial applications)

- Triton recommends for all commercial applications that, easily accessible, in-line filters are used to aid maintenance.

Hard water areas

- a. If it is intended to operate the shower in areas of hard water (above 200-ppm temporary hardness), a scale inhibitor may have to be fitted. For advice on the Triton scale inhibitor, please contact Customer Service.
- b. For best performance the showerhead MUST be regularly cleaned to remove scale and debris.

WATER SYSTEM REQUIREMENTS

This mixer shower is suitable for: -

- Gravity water systems.
- Pumped gravity systems.
- Fully modulating type combination boilers.
- Multi-point hot water heaters.
- Thermal storage.
- Unvented systems.

When installing this mixer with a Combination or multi-point boiler, it may be necessary to install flow regulation.

Check that the appliance is capable of delivering hot water at a minimum switch-on flow rate of 3 litres per minute. At flow rates between 3 and 8 litres per minute, the appliance must be capable of raising the water temperature to 52°C (minimum).

Water temperature at the inlet of the mixer valve must remain relatively constant when flow rate adjustments are made (refer to the appliance-operating manual to confirm compatibility with this mixer shower).

Where thermal store systems and instantaneous gas water heaters are used, if excessive draw-off take place the appliance may not be able to maintain an adequate output temperature. This could result in the shower temperature becoming noticeably cooler.

The hot supply temperature MUST remain a minimum of 10°C hotter than the required blend temperature for optimum performance.

***Fig.2** *(diagrammatic view – not to scale)

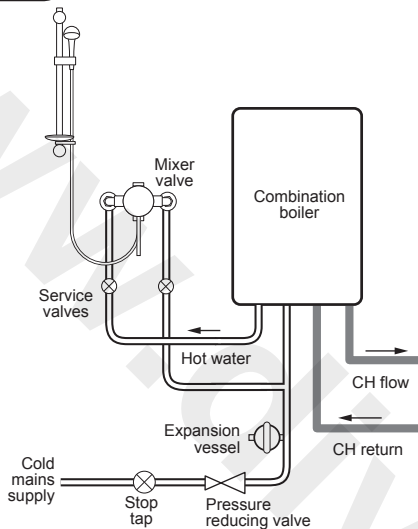

TYPICAL SUITABLE INSTALLATIONS

Instantaneous gas-heated systems, e.g. combination boilers (fig.2)

The shower control **MUST** be installed with a multipoint gas water heater or combination boiler of a fully modulating design (i.e. to maintain relatively stable hot water temperatures).

A drop tight pressure reducing valve **MUST** be fitted if the supply pressures exceed 5 bar running.

An expansion vessel, shown in (fig.2), **MUST** be fitted and regularly maintained, to prevent the shower mixer being damaged by excess pressures. This may already be installed within the boiler (check with manufacturer) and is in addition to the normally larger central heating expansion vessel.

The layout and sizing of pipework **MUST** be such that nominally equal inlet supply pressures are achieved and the effects of other draw-offs are minimised.

***Fig.3** *(diagrammatic view – not to scale)

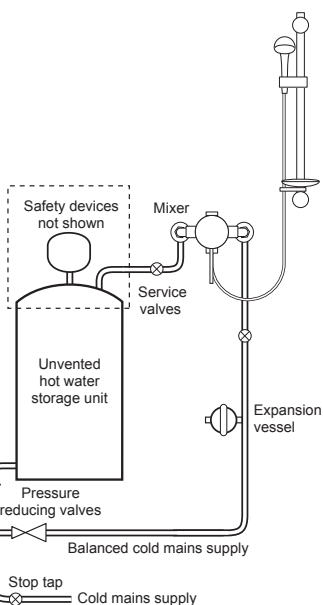

Unvented mains pressure systems (fig.3)

The shower control can be installed with an unvented, stored hot water cylinder.

For systems with no cold water take off after the appliance reducing valve, it will be necessary to fit an additional drop tight pressure reducing valve when the mains pressure is over 5 bar. The drop tight pressure reducing valve **MUST** be set at the same value as the unvented package pressure reducing valve.

Note: An additional expansion vessel (fig.3) may be required if a second pressure reducing valve is installed. This does not apply to packages with a cold take off after the pressure reducing valve to the cylinder.

The layout and sizing of pipework **MUST** be such that nominally equal inlet supply pressures are achieved and the effects of other draw-offs are minimised.

Mains pressurised thermal store systems (fig.4)

Packages of this type, fitted with a tempering valve (blender valve) can be used. A drop tight pressure reducing valve **MUST** be fitted if the supply pressures exceed 5 bar running.

An expansion vessel, shown in (fig.4), **MUST** be fitted, and regularly maintained, to prevent the unit being damaged by excess pressures. This may already be installed externally or internally within the thermal store (check with thermal store manufacturer).

Gravity fed systems (fig.5)

The shower control **MUST** be fed from a cold water cistern and hot water cylinder providing nominally equal pressures. There **MUST** be a minimum of one metre head of water. The minimum head distance is measured from the base of the cold water cistern to the top of the sprayhead.

If required, a twin impellor pump may be installed to increase the water pressure.

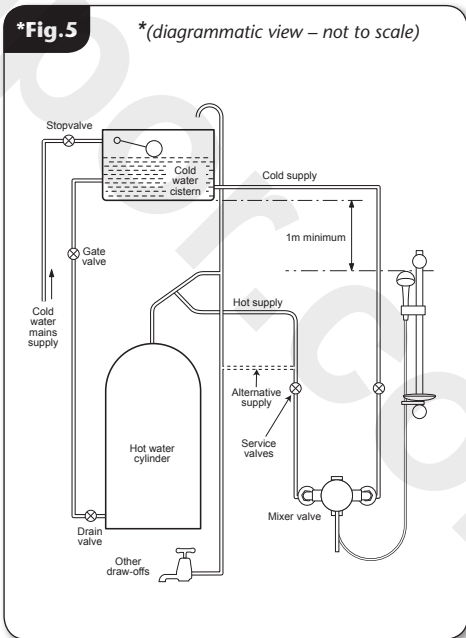
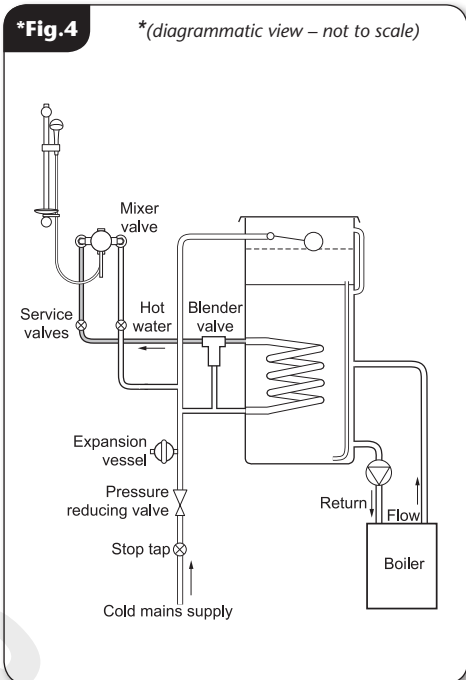

***Fig.7**

*(diagrammatic view – not to scale)

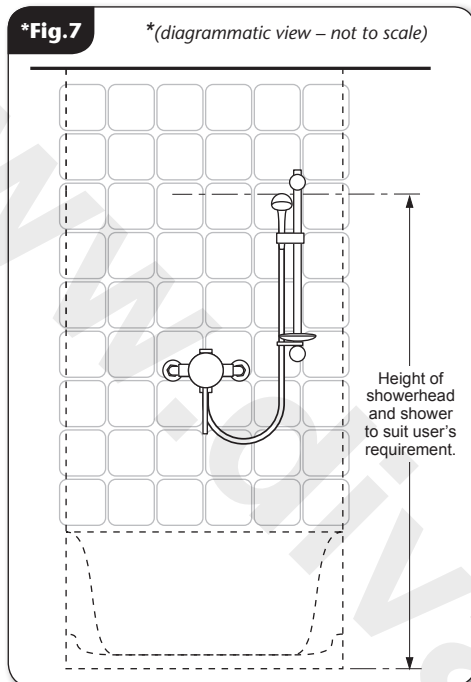
**WARNING!**

The shower must not be positioned where it will be subject to freezing conditions.

INSTALLATION**Preparing the mixer valve**

Check the contents to make sure all parts are present.

Before starting the mixer installation, make sure all the openings on the valve are carefully covered to stop ingress of any debris, etc. while routing the supply pipework.

The shower valve is suitable for exposed installation onto solid wall, a stud partition wall, dry lined wall or fixing to a laminate cubicle or panel.

Siting of the shower and accessories

Refer to **(fig.6)** for correct siting of the shower.

The mixer valve should be positioned, as detailed, with all controls within comfortable reach of the user.

The accessories (showerhead, riser rail) can be positioned above or to either side of the shower, refer to **(fig.6)**.

*(kits are for illustration purposes only)

Supply pipe work

Complete the pipework to the shower area having decided on the position of the shower and direction of pipe entry (for example rising, falling or rear entry)

The hot and cold water pipes should not be permanently attached to the wall within one metre of the valve, before installation is complete, to allow for final adjustment of the valve position.

Rear entry supplies

Using a spirit level, mark the route of incoming hot and cold water supply pipes at a distance of 150mm (approximately) between centres (fig.7).

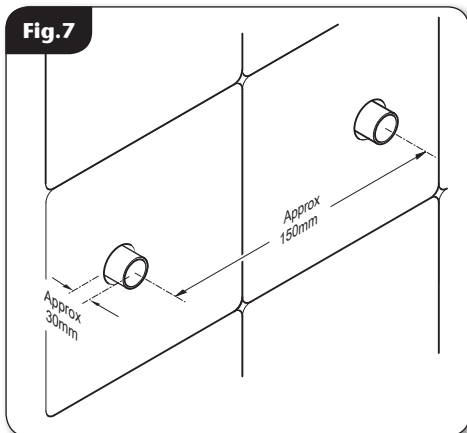

FITTING THE MIXER

Mark the position of the four locating screws for the mounting plate, although if installing to a solid brick wall using two diagonal holes will usually be enough.

Drill and plug the wall.

(An appropriate drill bit should be used. If the wall is brick, plasterboard or a soft building block, appropriate wall plugs and screws should be fitted).

Fit the mounting plate onto the wall (fig.8).

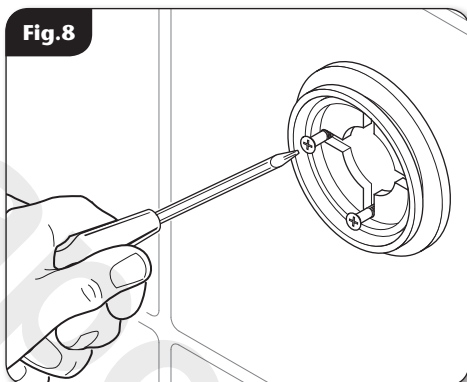

The inlet elbows allow for either rising, falling or rear entry hot and cold water supplies. The elbow adapters have two 'O' ring seals (fig.9) to the body and do not require PTFE tape or other means of sealing. The elbows each have a grub screw that will need tightening once the mixer is fitted to secure them to the elbow adaptors (fig.9).

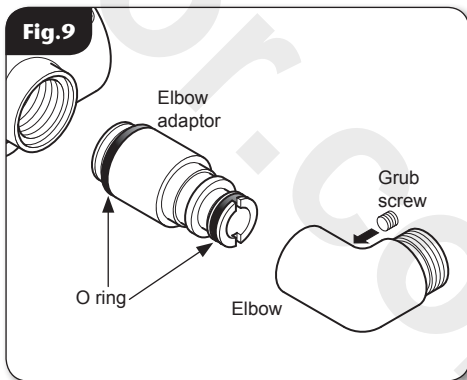
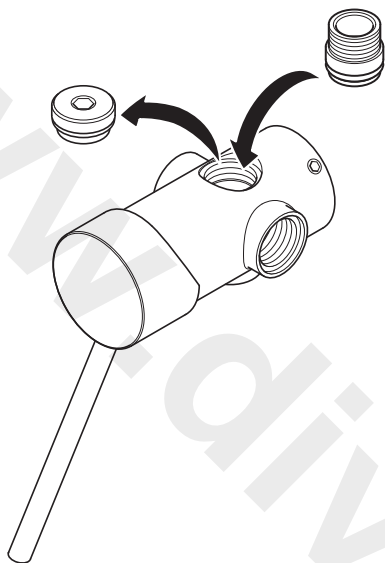

Fig.10



Bottom to top outlet change

Note: The outlet plug and adapter positions can be changed to accommodate top or bottom outlet (**fig.10**).

DO NOT rotate the mixer valve.

IMPORTANT: Make sure that all the supply pipework has been flushed through before fitting the mixer (**fig.11**).

Fig.11

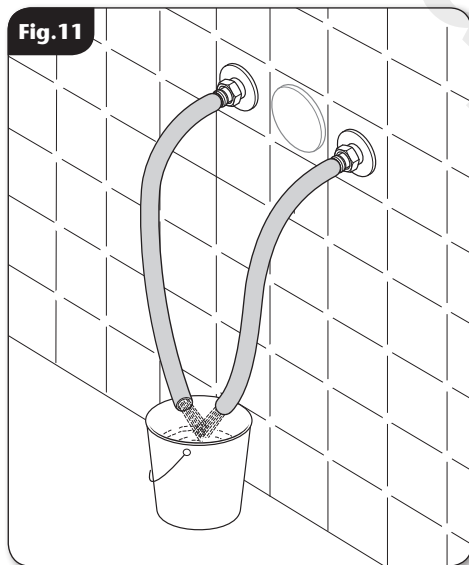

Fitting to the wall

Fit the trim onto the inlet pipes followed by the nut and olive (**fig.12**).

Connect the hot water supply to the inlet marked **HOT**, 'H' or red/orange label and connect the cold water supply to the inlet marked **COLD**, 'C' or blue label (**fig.12**).

Tighten all compression fittings

Tighten all the grub screws to secure the mixer to mounting plate.

FITTING THE CONTROL LEVER

Push the control lever onto the valve. Using an Allen key, secure the lever to the valve by tightening the screw on the underside of the lever and fit the trim (**fig.13**).

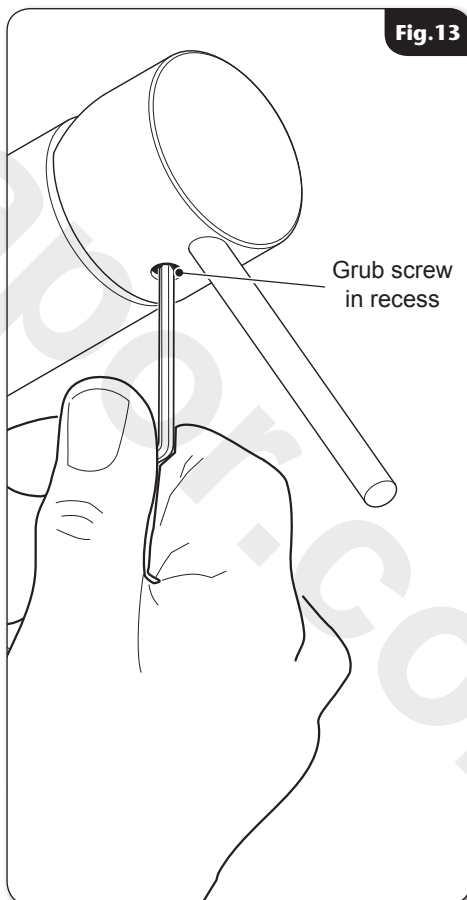
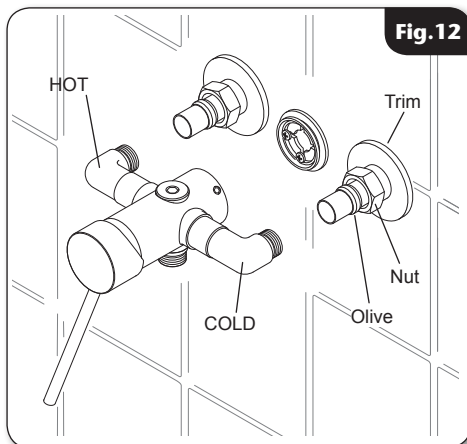
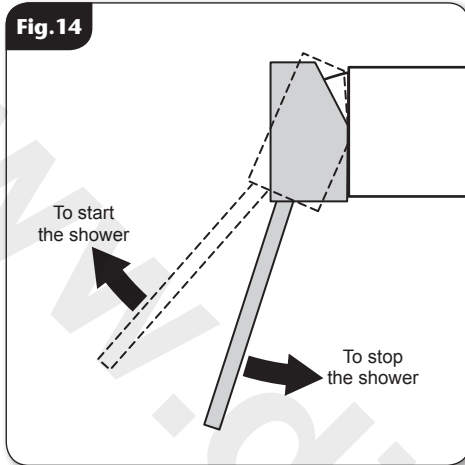

Fig.14



COMMISSIONING

Check that both hot and cold water supplies are fully open and at (or near to) their design temperature and pressures are within the requirements as stated.

Check the mixer can supply the maximum hot and maximum cold water demands.

OPERATING THE SHOWER

To start the shower, pull the control lever upwards for maximum flow (**fig.14**). To stop the water flow, push the control lever down (**fig.14**).

To adjust the water temperature, turn the control lever clockwise for a hotter shower and anti-clockwise for a cooler shower (**fig.15**).

WARNING!

This mixer shower is NOT thermostatic and WILL NOT prevent water from flowing from the sprayhead should there be a loss of one supply to the mixer.

CLEANING

DO NOT use abrasive or solvent cleaning fluids. The shower unit, riser rail, hose, etc. should be cleaned using a soft cloth and warm water.

IT IS IMPORTANT TO KEEP THE SPRAYHEAD CLEAN TO MAINTAIN THE PERFORMANCE OF THE SHOWER. The hardness of the water will determine the frequency of cleaning. For example, if the shower is used every day in a very hard water area, it may be necessary to clean the sprayhead on a weekly basis.

Fig.15

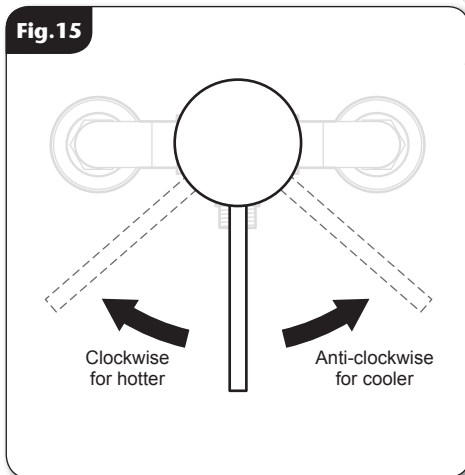

FLOW CHART

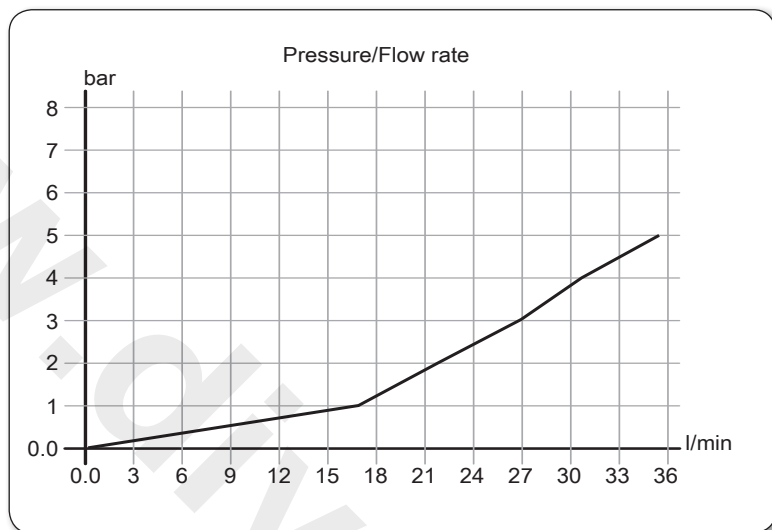

- Flow rate at 38°C
- Flow control fully open
- Open outlet
- No flow regulator fitted

DIMENSIONS

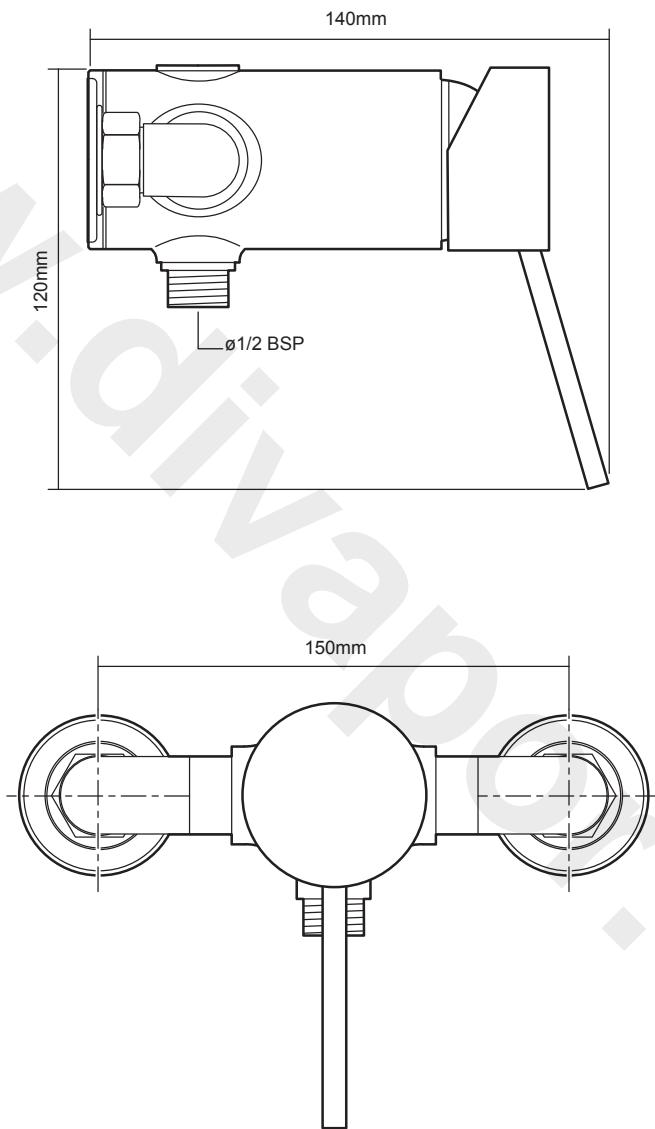

All dimensions listed in this fitting book regarding the product and installation are approximate.

SPARE PARTS

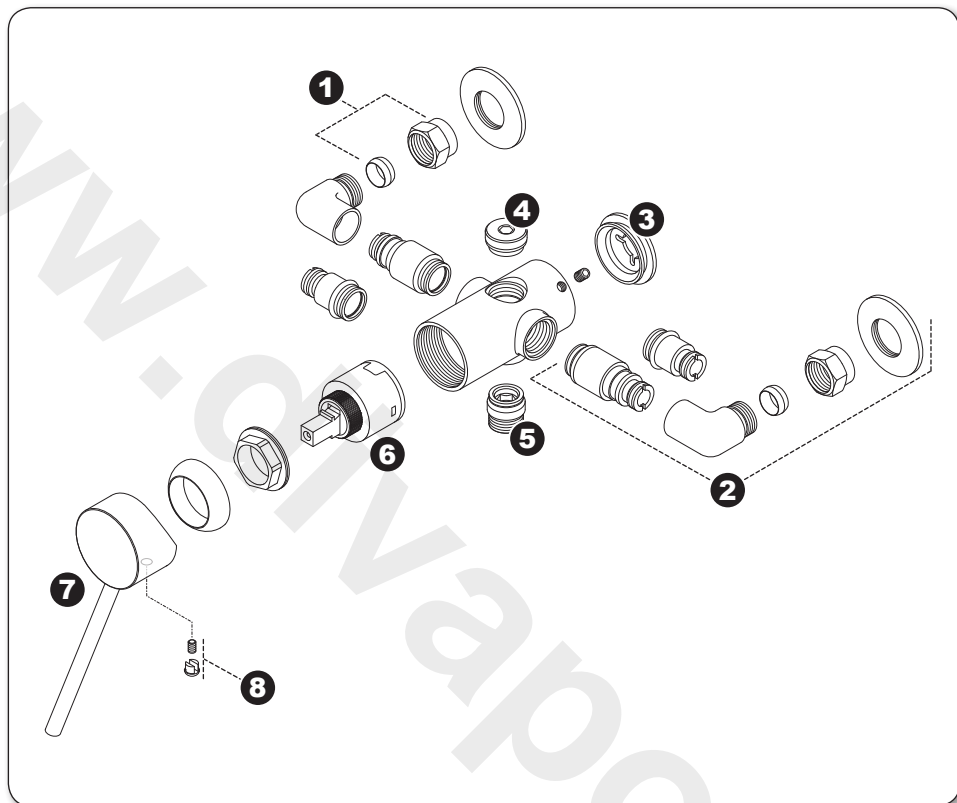

Ref.	Description	Part No.
1.	Nut and olive	83312790
2.	Elbow assembly	83313810
3.	Mounting plate	83313820
4.	Blanking plug	83313830
5.	Outlet connector	83313840
6.	Flow cartridge	83313850
7.	Control handle	86003570
8.	Grub screw and trim	83313540

FAULT FINDING

The following can be carried out by a competent person

<i>Problem/Symptom</i>	<i>Cause</i>	<i>Action/Cure</i>
1 Water too hot.	1.1 Not enough cold water flowing through shower.	1.1.1 Turn the control lever anti-clockwise.
	1.2 Increase in the ambient cold water temperature.	1.2.1 Turn turn control lever anti-clockwise.
	1.3 Cold water supply blocked.	1.3.1 Turn off shower and consult a competent plumber or contact Triton Customer Service.
	1.4 High volume of cold water drawn off elsewhere.	1.4.1 Reduce the simultaneous demand from the mains supply.
2 Water too cold.	2.1 Not enough hot water flowing through shower.	2.1.1 Turn the control lever clockwise.
	2.2 Decrease in the ambient cold water temperature.	2.2.1 Turn the control lever clockwise.
	2.3 Insufficient hot water supplies from the heating system.	2.3.1 Make sure heating appliance is set to maximum or has sufficient stored hot water. 2.3.2 Make sure heating appliance is igniting by trying a hot water tap elsewhere.
	2.4 Hot water supply blocked or restricted.	2.4.1 Turn shower off and consult a competent plumber or contact Triton Customer Service.
3 Water does not flow or shower pattern collapses when another outlet is turned on.	3.1 Water supplies cut off.	3.1.1 Check water elsewhere in house and if necessary contact local water company.
	3.2 Blockage in pipework.	3.2.1 Turn the shower off and consult a suitably competent plumber.
	3.3 Sprayhead blocked.	3.3.1 Clean sprayhead.
	3.4 System not capable of supplying multiple outlets at the same time.	3.4.1 Reduce the simultaneous demand. 3.4.2 Check stop or service valve is fully open. 3.4.3 Check if sufficient water pressure.
4 Water too cold.	4.1 Running pressure in excess of maximum recommended.	4.1.1 Fit a pressure reducing valve.
5 Shower controls noisy while in use.	5.1 Running pressure in excess of maximum recommended.	5.1.1 Fit a pressure reducing valve.

www.divapor.com

www.divapor.com

www.divapor.com

UK SERVICE POLICY

In the event of a product fault or complaint occurring, the following procedure should be followed:

1. Telephone Customer Service on **0844 980 0750** having available, your details including post code, the model number and power rating of the product, together with the date of purchase and, where applicable, details of the particular fault.
2. If required, the Customer Service Advisor will arrange for a qualified engineer to call.
3. All products attended to by a Triton service engineer must be installed in full accordance with the Triton installation guide applicable to the product. (Every product pack contains an installation guide, however, they can also be bought via our Customer Service Spares Department).
4. Our engineer will require local parking and if a permit is required this must be available to the engineer on arrival at the call.
5. It is essential that you or an appointed representative (*who must be over 18 years of age*) is present for the duration of the service engineer's visit. If the product is in guarantee you must produce proof of purchase.
6. Where a call under the terms of guarantee has been booked and the failure is not product related (*i.e. scaling and furring, incorrect water pressure, pressure relief device operation or electrical/plumbing installation fault*) a charge will be made. A charge will also be issued if nobody is at home when the service engineer calls or adequate parking/permit is not available.
7. If the product is no longer covered by the guarantee an up front fixed fee will be charged before the site visit.
8. Should proof of purchase not be available on an "in-guarantee" call, or should the service engineer find that the product is no longer under guarantee, the engineer will charge the same fixed price and the customer will be expected to pay the engineer before he leaves. If payment is not made on the day an administration charge will be added to the fixed charge.
9. If a debt is outstanding from a previous visit, or from any other Triton purchase. Triton reserves the right to withhold service until the debt has been settled.
10. Triton takes the health, safety and wellbeing of its employees very seriously and expects customers to treat all staff members with respect. Should any employee feel threatened or receive abuse, either verbally or physically, Triton reserves the right to withhold service and will support the employee with a legal prosecution.

Replacement Parts Policy

It is the policy of Triton Showers to maintain parts availability for the duration of production and a period of 5 years thereafter in accordance with industry standards. In the event of a spare part not being available a substitute part will be supplied.

Spare parts can be ordered via our online spare parts store, or by telephoning Triton Spares Department. Payment should be made by credit/debit card (*excluding American Express or Diners Card*). Payment can also be made by pre-payment of a pro-forma invoice, by cheque or postal order.

Telephone orders are based on information given during of the call. Before contacting Triton, please verify your requirements using the information contained in the user guide. Triton cannot accept liability for incorrect part identification.

Triton Showers
Triton Road
Nuneaton
Warwickshire CV11 4NR

Triton is a division of Norcros Group (Holdings) Limited

TRITON STANDARD GUARANTEE

Triton guarantee this product against all mechanical defects arising from faulty workmanship or materials for a period of five years for domestic use only, from the date of purchase, provided that it has been installed by a competent person in full accordance with the fitting instructions.

Any part found to be defective during this guarantee period we undertake to repair or replace at our option without charge so long as it has been properly maintained and operated in accordance with the operating instructions, and has not been subject to misuse or damage.

This product must not be taken apart, modified or repaired except by a person authorised by Triton. This guarantee applies only to products installed within the United Kingdom and does not apply to products used commercially. This guarantee does not affect your statutory rights.

What is not covered:

1. Breakdown due to: **a)** use other than domestic use by you or your resident family; **b)** wilful act or neglect; **c)** any malfunction resulting from the incorrect use or quality of electricity, gas or water or incorrect setting of controls; **d)** failure to install in accordance with this installation guide.
2. Claims for missing parts once the product has been installed.
3. Repair costs for damage caused by foreign objects or substances.
4. Total loss of the product due to non-availability of parts.
5. Compensation for loss of use of the product or consequential loss of any kind.
6. Call out charges where no fault has been found with the appliance.
7. Call out charges where the water supply cannot be isolated, this includes consequential losses arising from unserviceable supply valves.
8. The cost of repair or replacement of pressure relief devices, showerheads, hoses, riser rails and/or wall brackets, isolating switches, electrical cable, fuses and/or circuit breakers or any other accessories installed at the same time.
9. The cost of routine maintenance, adjustments, overhaul modifications or loss or damage arising therefrom, including the cost of repairing damage, breakdown, malfunction caused by corrosion, furring, pipe scaling, limescale, system debris or frost.

For the latest Terms & Conditions, please see:
www.tritonshowers.co.uk

Customer Service: ☎ **0844 980 0750**

Trade Installer Hotline: ☎ **0844 980 0730**

Fax: **0844 980 0744**

www.tritonshowers.co.uk

E-mail: **serviceenquiries@tritonshowers.co.uk**