

unichrome

TRITON

NENE

Thermostatic bar mixer shower



Installation and Operating Instructions

INSTALLERS PLEASE NOTE THESE INSTRUCTIONS ARE TO BE LEFT WITH THE USER

CONTENTS	Page
Introduction	1
Safety warnings	1
Main components	2
Site requirements	3
Typical suitable installations	4 – 5
Instantaneous water heater appliance capabilities	6
Preparing the mixer valve	6
Siting of the shower	7
Installation	7 – 8
Leak testing	8
Commissioning	8 – 9
Operating the shower	9
Cleaning the filters	9
Spare parts	11
Fault finding	11 – 12
Guarantee, service policy, etc.	rear cover

To check the product suitability for commercial and multiple installations, please contact Triton's specification advisory service before installation.

Telephone: +44 (0) 24 7632 5491

Facsimile: +44 (0) 24 7632 4564

E mail: technical@triton.plc.uk

INTRODUCTION

This book contains all the necessary fitting and operating instructions for your Unichrome Nene thermostatic bar mixer shower.

Please read the instructions carefully. Read through the whole of this book BEFORE beginning your installation.

The shower installation MUST be carried out by a suitably competent person and in sequence of this instruction book.

Care taken during the installation will provide a long and trouble free life from your shower.

For best performance within the specified running pressure range a minimum flow of eight litres per minute should be available to both inlets.

The mixer shower MUST NOT be subjected to water temperatures above 80°C.

The mixer is designed for use with traditional low pressure 'gravity' water systems, using a cold water cistern and hot water cylinder.

All the models are suitable for the higher pressure systems found in the UK up to a maximum of 5 bar running pressure.

IMPORTANT: When installing this mixer with a combination boiler or multi-point, flow restricters MUST be installed in the unit.

The mixer is suitable for fully modulating type combination boilers and multi-point hot water heaters. It is also suitable for thermal storage, unvented systems and pumped gravity systems.

IMPORTANT: Before installing with a gas instantaneous water heater, make sure it is capable of delivering hot water at a minimum switch-on flow rate of 3 litres per minute.

At flow rates between 3 and 8 litres per minute, the appliance must be capable of raising the water temperature to a minimum of 52°C. Water temperature at the inlet to the mixer must remain relatively constant when flow rate adjustments are made (*refer to the water heater operating manual to confirm compatibility with this mixer shower*).

This mixer is supplied with an integral single check valve and integral filter in each inlet. Inlet connections are to 15mm compression or ½" BSP female fittings (not supplied).

SAFETY WARNINGS

- a Layout and sizing of pipework must be such that when other services are used, pressures at the shower control inlets do not fall below the recommended minimum.
- b **DO NOT choose a position where the shower could become frozen.**
- c **DO NOT connect this mixer shower to any form of tap or fitting not recommended by the manufacturer.**
- d The showerhead MUST be regularly cleaned to remove scale and debris.
- e Conveniently situated service valves in each inlet supply MUST be fitted as an independent method of isolating the shower should maintenance or servicing be necessary.
- f If it is intended to operate the shower in areas of hard water (above 200 ppm temporary hardness), a scale inhibitor may have to be fitted. For advice on the Triton scale inhibitor, please contact Customer Service.
- g **DO NOT operate the shower outside the guidelines as laid out in 'site requirements'.**

Replacement parts can be ordered from Triton Customer Service. See 'spare parts' for details and part numbers.

Due to continuous improvement and updating, specification may be altered without prior notice.

COMPONENTS (Fig.1)

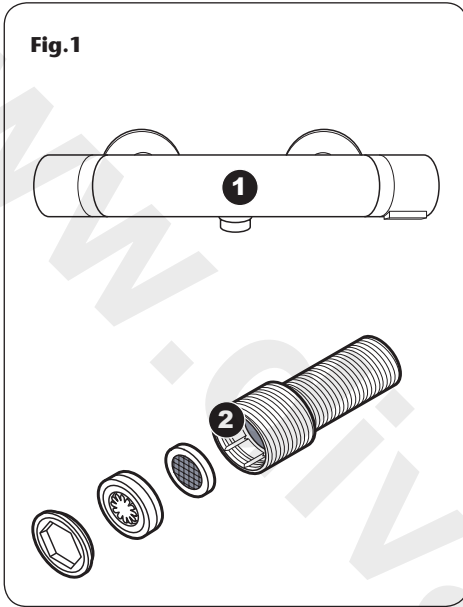

- 1** Nene thermostatic mixer valve
- 2** Long thread straight inlet connector
- 3** Showerhead (*not shown*)
- 4** Riser rail assembly (*not shown*)

SITE REQUIREMENTS

The installation must be in accordance with Water Regulations and Byelaws.

Running water pressure:

Gravity fed – 0.1 bar min. to 1.0 bar max.
Mains fed – 1.0 bar min. to 5.0 bar max.

Maximum static water pressure:

Gravity and mains – 10 bar

DO NOT connect the mixer shower to a gravity hot supply and a mains cold supply (or vice versa).

For the best performance within the specified running pressure range a minimum flow of eight litres per minute should be available to both inlets.

While the mixer shower is operational (open outlet), inlet pressures must not be capable of exceeding 7 bar. For effective operation of the internal seals, the maximum static pressure must not be exceeded.

Note: On sites where the running pressure is above 5 bar, the use of a suitably sized pressure reducing valve fitted in the cold mains supply pipework can provide nominally equal pressures at the mixer shower.

The pipework should be installed such that the flow is not significantly affected by other taps and appliances being operated elsewhere on the premises.

Where thermal store systems and instantaneous gas water heaters are used, if excessive draw-offs take place the boiler may not be able to maintain an adequate output temperature. This could result in the shower temperature becoming noticeably cooler.

Water temperature requirements

Maximum hot water temperature = 80°C

Recommended maximum = 65°C

Minimum hot water temperature = 52°C

Maximum cold water temperature = 20°C

BS 6700 recommends that the temperature of stored water should never exceed 65°C.

A stored water temperature of 60°C is considered high enough to meet all normal requirements and will minimise the effects of scale in hard water areas.

Temperature adjustment range

The mixed water temperature can be adjusted from cold through to a top limit which can be preset during installation. This is with full anti-scald protection throughout the range (35°C to 40°C) providing the hot water temperature at the inlet remains 10°C above the outlet temperature.

IMPORTANT: This shower will shut off if there is a loss of water to either supply.

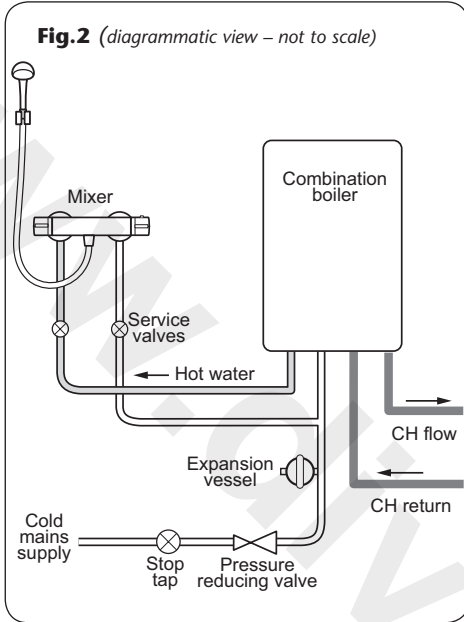

TYPICAL SUITABLE INSTALLATIONS

a) Instantaneous gas-heated systems, e.g. combination boilers (fig.2)

The shower control **MUST** be installed with a multipoint gas water heater or combination boiler of a fully modulating design (i.e. to maintain relatively stable hot water temperatures).

A drop tight pressure reducing valve **MUST** be fitted if the supply pressures exceed 5 bar running.

An expansion vessel (shown in **fig.3**) **MUST** be fitted, and regularly maintained, to prevent the shower mixer being damaged by excess pressures. This may already be installed within the boiler (check with manufacturer) and is in addition to the normally larger central heating expansion vessel.

The layout and sizing of pipework **MUST** be such that nominally equal inlet supply pressures are achieved and the effects of other draw-offs are minimised. The hot supply temperature **MUST** remain a minimum of 10°C hotter than the required blend temperature for optimum performance.

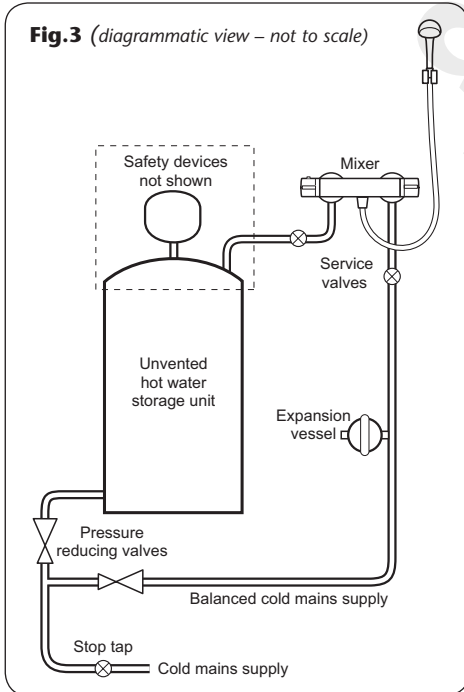

b) Unvented mains pressure systems (fig.3)

The shower control can be installed with an unvented, stored hot water cylinder.

For systems with no cold water take off after the appliance reducing valve, it will be necessary to fit an additional drop tight pressure reducing valve when the mains pressure is over 5 bar. The drop tight pressure reducing valve must be set at the same value as the unvented package pressure reducing valve.

Note: An additional expansion vessel (**fig.3**) may be required if a second pressure reducing valve is installed. This does not apply to packages with a cold take off after the pressure reducing valve to the cylinder.

The layout and sizing of pipework **MUST** be such that nominally equal inlet supply pressures are achieved and the effects of other draw-offs are minimised.

c) Mains pressurised thermal store systems (fig.4)

Packages of this type, fitted with a tempering valve (blender valve) can be used. A drop tight pressure reducing valve MUST be fitted if the supply pressures exceed 5 bar running.

An expansion vessel (shown in **fig.4**) MUST be fitted, and regularly maintained, to ensure the unit is not damaged by excess pressures. This may already be installed externally or internally within the thermal store (check with thermal store manufacturer).

d) Gravity fed systems (fig.5)

The shower control MUST be fed from a cold water cistern and hot water cylinder providing nominally equal pressures. There must be a minimum of 1 metre head of water. The minimum head distance is measured from the base of the cold water cistern to top of the showerhead.

e) Pumped gravity fed systems (fig.6)

The shower control MUST be fed from a cold water cistern and hot water cylinder providing nominally equal pressures.

The mixer unit may be used with a gravity fed system with a pump to boost pressures as shown.

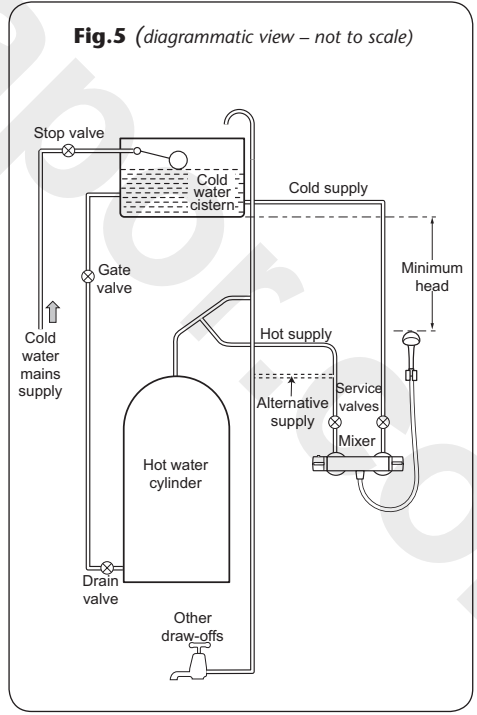
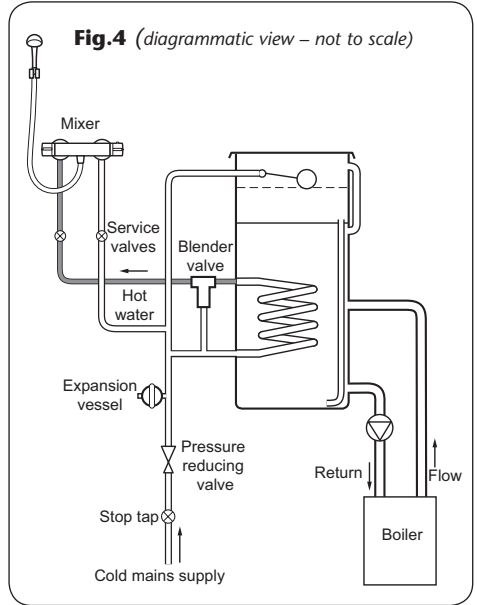
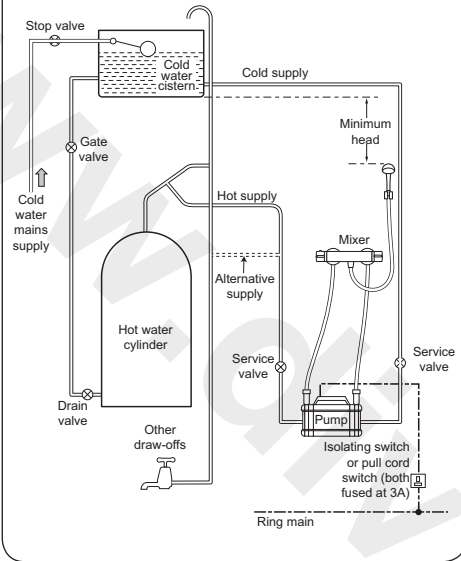

Fig.6 (diagrammatic view – not to scale)



INSTANTANEOUS WATER HEATERS APPLIANCE CAPABILITIES

In order to provide the best performance from the shower when connected to an instantaneous water heater, the appliance must be capable of raising the temperature of the incoming water to a minimum of 52°C (125°F) and delivering a flow rate of not less than eight litres per minute.

Flow regulators supplied MUST be inserted into the long thread straight connectors as follows:

Insert the filter, then the flow regulator (**Fig.7**) and secure in place with the threaded retainer. With the flow regulator fitted and when the system is in use, the On/Off flow control should be turned fully anti-clockwise to the full flow setting.

PREPARING THE MIXER VALVE

WARNING!

The shower must not be positioned where it will be subject to freezing conditions.

Fig.7

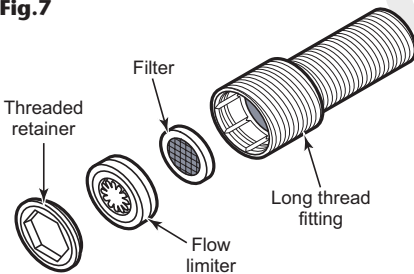

Check the contents to make sure all parts are present.

Before installing, make sure all the openings on the valve are carefully covered to stop ingress of any debris, etc. while routing the supply pipework.

The shower valve is suitable for installation on a solid wall, a stud partition wall, dry lined wall or fixing to a laminate cubicle or panel.

The hot and cold water pipes should be securely attached within the wall or panel to support the valve and prevent movement after installation.

The hot water inlet has a red symbol next to the inlet and must be on the left-hand side.

SITING OF THE SHOWER

Refer to **(fig.8)** for correct siting of the shower.

Position the shower and showerhead on the wall so that all controls can be comfortably reached while using the shower. The showerhead can be positioned either side of the shower.

The unit must be positioned horizontally with the outlet port at the bottom.

INSTALLATION

Note: The outlet of the shower MUST NOT be connected to anything other than the showerhead supplied.

DO NOT use jointing compounds on any pipe fittings for the installation.

DO NOT solder fittings near the shower unit as heat can transfer along the pipework and damage components.

Note: Suitable service valves (complying with Water Regulations and Byelaws) MUST be fitted on the hot and cold water supplies to the shower as an independent means of isolating the water supplies should maintenance or servicing be necessary.

When connecting the pipework avoid using tight 90° elbows. Swept or formed bends will give the best performance.

Straight fittings

The supply pipes can be routed either from the side, rising, rear or falling and must end in suitable fittings **(fig.9)** to accept the long thread connectors.

The straight connectors can be used to connect to ½" BSP female elbow fittings in solid wall installations. The inlet centres on the shower valves must be aligned horizontally and centred to 150mm.

The hot and cold supply pipes must be anchored rigidly to support the valve and stop any movement after installation.

If installing in hollow walls or laminate cubicles, fittings are supplied to compress onto the wall to support the mixer valve **(fig.10)**.

Fig.8 (diagrammatic view – not to scale)

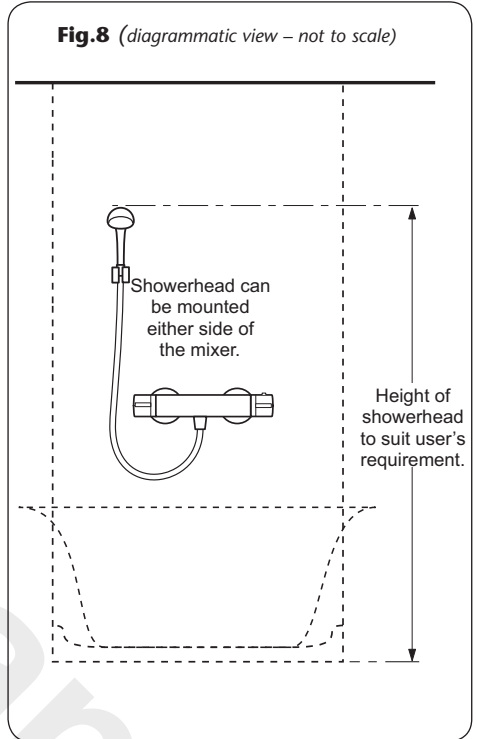

Fig.9

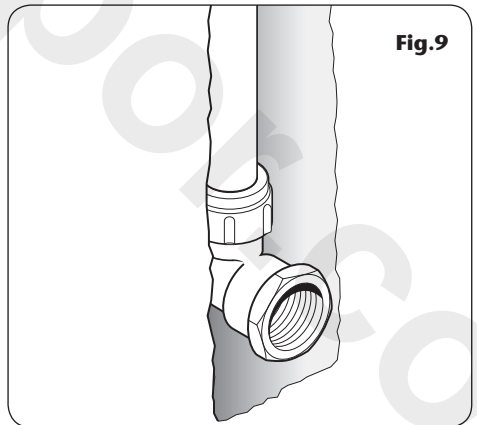
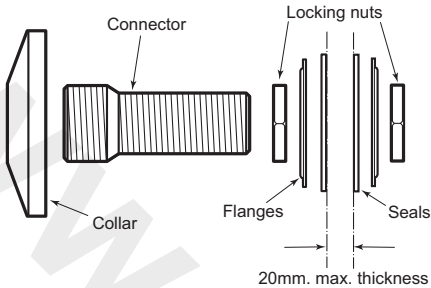

Fig.10



The maximum thickness of wall is about 20mm. Enough room must be left on the connector to fit the compression nut and olive. At the front end, an allowance **MUST** be made to accept the shower union and collar.

Flush out the pipework in accordance with Water Regulations and Byelaws.

Connect 15mm pipework using standard compression nuts and olives (**fig.11**).

Screw the supplied collars onto the fittings until tight to the wall.

Offer the shower valve to the fittings and, checking that the sealing washers are place, screw the unions onto the fittings.

If installing with a combi multipoint system make sure the flow regulators are fitted.

Fig.11

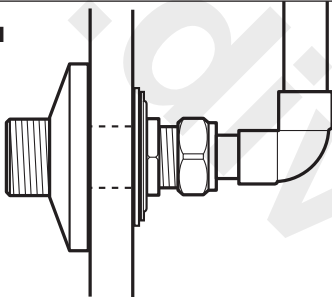

LEAK TESTING

Fit the hose to the outlet and direct it to waste. Open the supplies and test for leaks in the valve connections. Remedy any leaks if necessary.

COMMISSIONING

Make sure that both the hot and cold water supplies are fully open and at (or near to) their design temperature and pressures, and are within the requirements as stated.

Check the temperature knob (right-hand side) is rotated fully anti-clockwise (press the override button to achieve maximum temperature setting).

Make sure the showerhead is directed to waste. Start the water flow by turning the flow control (left-hand side) anti-clockwise.

Allow the shower to run at the maximum temperature setting until the water temperature has stabilised. Using the temperature control knob, rotate until your desired maximum showering temperature is reached.

The mixer valve contains a maximum temperature override button set at 40°C.

The mixer valve is factory set to give a maximum outlet temperature of 40°C. This should be checked on site to make sure the setting has not been altered and also to make sure of user safety.

Adjusting the maximum temperature override setting

When you are satisfied with the showering temperature remove the temperature control knob by undoing the grub screw (**fig.12**).

Reposition the control on the spline so the peg inside the control engages against the stop (**fig.13**) on the temperature control body.

Refit the controls and secure in place with the screw.

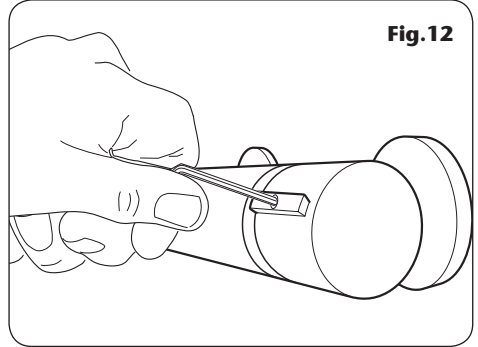

Fig.12

OPERATING THE SHOWER

To start the shower, rotate the On/Off flow lever (left-hand side) fully anti-clockwise for maximum flow.

To stop the water flow, rotate the On/Off flow lever fully clockwise.

To adjust the water temperature, rotate the temperature control (right-hand side) – clockwise for a cooler shower or anti-clockwise for a hotter shower.

To overcome the maximum temperature stop, depress the red button.

CAUTION: Exposed metal surfaces may become hot during use.

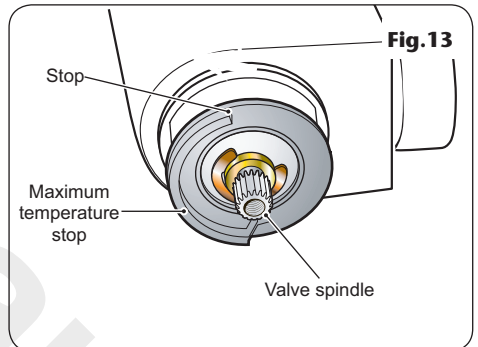

Fig.13

CLEANING THE FILTERS

Turn off the water supplies before starting.

To gain access to the filters remove the unit from the inlet fittings.

Remove the sealing washers from the union inlets and unscrew the filter cap on each inlet (**fig.14**). Remove the filter and wash the filter thoroughly under running water to remove all debris. Replace the filter into the recess on the cap and screw the unit back into each inlet union.

Reassemble the shower to the inlet fittings.

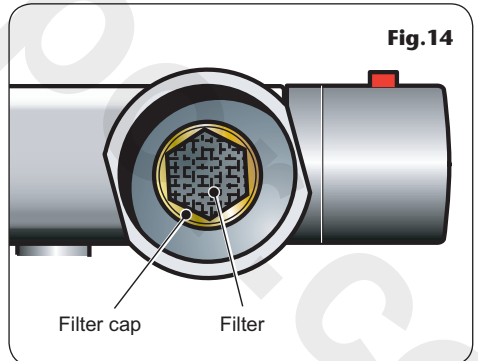
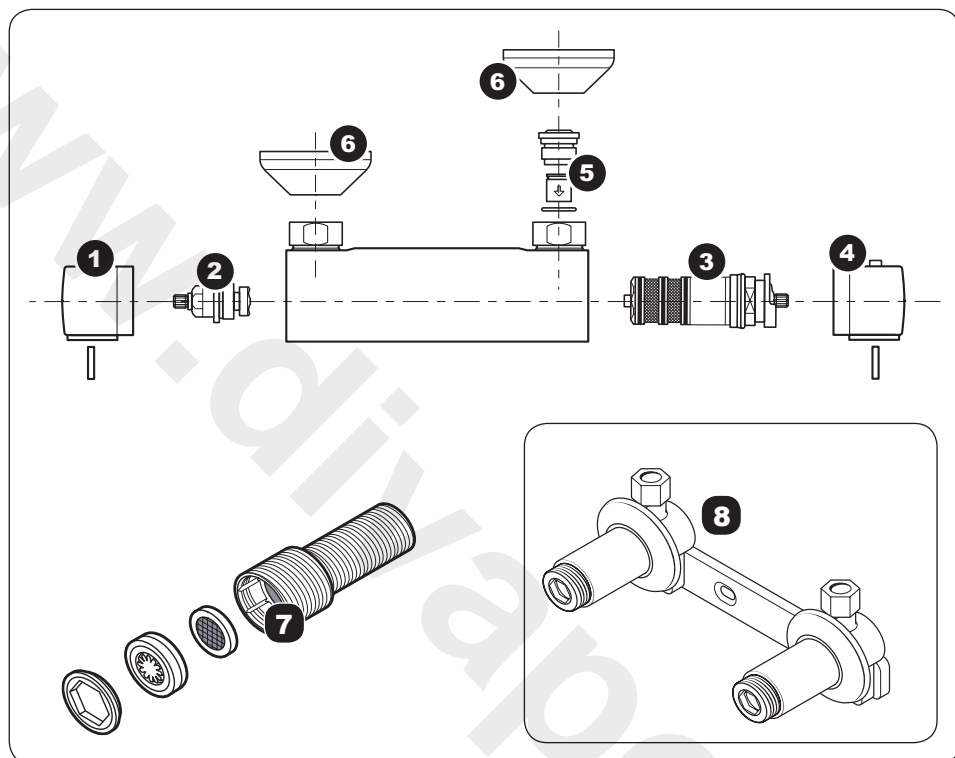

Fig.14

SPARE PARTS



<i>Ref.</i>	<i>Description</i>	<i>Part No.</i>	<i>Ref.</i>	<i>Description</i>	<i>Part No.</i>
1	Closure knob	83307440	8	Bar bracket (optional)	UNBMXBKT
2	Mechanic headwork	83307320			
3	Thermostatic cartridge	83307460			
4	Regulation knob	83307470			
5	Non-return valve	83307290			
6	Trim pack	86001150			
7	Straight inlet connector	UNPIPCON			

FAULT FINDING

The following can be carried out by a competent person

Problem/Symptom	Cause	Action/Cure
1 Water too hot.	1.1 Temperature control incorrectly commissioned.	1.1.1 Refer to commissioning section.
	1.2 Not enough cold water flowing through shower.	1.2.1 Turn temperature control anti-clockwise.
	1.3 Increase in the ambient cold water temperature.	1.3.1 Turn temperature control anti-clockwise.
	1.4 Cold water supply blocked.	1.4.1 Turn off shower and consult a competent plumber or contact Triton Customer Service.
	1.5 High volume of cold water drawn off elsewhere.	1.5.1 Reduce the simultaneous demand from the supply.
2 Water too cold.	2.1 Temperature control incorrectly commissioned.	2.1.1 Refer to commissioning section.
	2.2 Not enough hot water flowing through shower.	2.2.1 Turn the temperature control clockwise.
	2.3 Decrease in the ambient cold water temperature.	2.3.1 Turn the temperature control clockwise.
	2.4 Insufficient hot water supplies from the heating system.	2.4.1 Make sure heating appliance is set to maximum or has sufficient stored hot water. 2.4.2 Make sure heating appliance is igniting by trying a hot water tap elsewhere.
	2.5 Hot water supply blocked or restricted.	2.5.1 Turn off shower and consult a competent plumber or contact Triton Customer Service.
	2.6 Flow regulator not fitted (HP systems only).	2.6.1 Fit the supplied flow regulator in the showerhead (see ' <i>instantaneous gas water heaters</i> ').
3 High water flow and/or poor performance on a mains fed system.	3.1 Flow regulators not fitted.	3.1.1 Fit the supplied regulator in the showerhead or inlets depending upon model (see ' <i>high pressure systems</i> ').

FAULT FINDING

The following is recommended for a professional qualified installer only

Problem/Symptom	Cause	Action/Cure
4 Water does not flow or shower pattern collapses when another outlet is turned on.	4.1 Water supplies cut off.	4.1.1 Check water elsewhere in house and if necessary contact local water company.
	4.2 Shower unit blocked.	4.2.1 Inspect the inlet filters. Clean if necessary.
	4.3 Blockage in pipework.	4.3.1 Turn off the shower and consult a suitably competent plumber.
	4.4 Showerhead blocked.	4.4.1 Clean showerhead.
	4.5 System not capable of supplying multiple outlets at the same time.	4.5.1 Reduce the simultaneous demand. 4.5.2 Make sure stop/service valves are fully open. 4.5.3 Check if sufficient water pressure.
5 Water too cold.	5.1 Running pressure in excess of maximum recommended.	5.1.1 Fit a pressure reducing valve.
6 Shower controls noisy while in use.	6.1 Running pressure in excess of maximum recommended.	6.1.1 Fit a pressure reducing valve.
7 Shower will not shut off.	7.1 Flow control washer worn.	7.1.1 Renew flow control washer.

www.divapor.com

UK SERVICE POLICY

In the event of a product fault or complaint occurring, the following procedure should be followed:

1. Telephone Customer Service on **0844 980 0750** having available, your details including post code, the model number and power rating of the product, together with the date of purchase and, where applicable, details of the particular fault.
2. If required, the Customer Service Advisor will arrange for a qualified engineer to call.
3. All products attended to by a Triton service engineer must be installed in full accordance with the Triton installation guide applicable to the product. *(Every product pack contains an installation guide, however, they can also be bought via our Customer Service Spares Department).*
4. Our engineer will require local parking and if a permit is required this must be available to the engineer on arrival at the call.
5. It is essential that you or an appointed representative (*who must be over 18 years of age*) is present for the duration of the service engineer's visit. If the product is in guarantee you must produce proof of purchase.
6. Where a call under the terms of guarantee has been booked and the failure is not product related (*i.e. scaling and furring, incorrect water pressure, pressure relief device operation or electrical/plumbing installation fault*) a charge will be made. A charge will also be issued if nobody is at home when the service engineer calls or adequate parking/permit is not available.
7. If the product is no longer covered by the guarantee an up front fixed fee will be charged before the site visit.
8. Should proof of purchase not be available on an "in-guarantee" call, or should the service engineer find that the product is no longer under guarantee, the engineer will charge the same fixed price and the customer will be expected to pay the engineer before he leaves. If payment is not made on the day an administration charge will be added to the fixed charge.
9. If a debt is outstanding from a previous visit, or from any other Triton purchase. Triton reserves the right to withhold service until the debt has been settled.
10. Triton takes the health, safety and wellbeing of its employees very seriously and expects customers to treat all staff members with respect. Should any employee feel threatened or receive abuse, either verbally or physically, Triton reserves the right to withhold service and will support the employee with a legal prosecution.

Replacement Parts Policy

Availability: It is the policy of the manufacturer to maintain parts availability for the duration of production and a period of five years thereafter, in accordance with industry standards.

Spare parts are available via our website, **www.tritonshowers.co.uk**, or by telephoning Triton Customer Service Spares Department. Payment should be made by credit/debit card (*excluding American Express or Diners Card*).

Payment can also be made by pre-payment of a pro forma invoice by cheque or money order.

TRITON STANDARD GUARANTEE

Triton guarantee this product against all mechanical defects arising from faulty workmanship or materials for a period of five years for domestic use only, from the date of purchase, provided that it has been installed by a competent person in full accordance with the fitting instructions.

Any part found to be defective during this guarantee period we undertake to repair or replace at our option without charge so long as it has been properly maintained and operated in accordance with the operating instructions, and has not been subject to misuse or damage.

This product must not be taken apart, modified or repaired except by a person authorised by Triton. This guarantee applies only to products installed within the United Kingdom and does not apply to products used commercially. This guarantee does not affect your statutory rights.

What is not covered:

1. Breakdown due to: **a)** use other than domestic use by you or your resident family; **b)** wilful act or neglect; **c)** any malfunction resulting from the incorrect use or quality of electricity, gas or water or incorrect setting of controls; **d)** failure to install in accordance with this installation guide.
2. Repair costs for damage caused by foreign objects or substances.
3. Total loss of the product due to non-availability of parts.
4. Compensation for loss of use of the product or consequential loss of any kind.
5. Call out charges where no fault has been found with the appliance.
6. Call out charges where the water supply cannot be isolated, this includes consequential losses arising from unserviceable supply valves.
7. The cost of repair or replacement of pressure relief devices, showerheads, hoses, riser rails and/or wall brackets, isolating switches, electrical cable, fuses and/or circuit breakers or any other accessories installed at the same time.
8. The cost of routine maintenance, adjustments, overhaul modifications or loss or damage arising therefrom, including the cost of repairing damage, breakdown, malfunction caused by corrosion, furring, pipe scaling, limescale, system debris or frost.

Triton Showers
Triton Road
Nuneaton
Warwickshire CV11 4NR

Triton is a division of Norcros Group (Holdings) Limited

Customer Service: ☎ **0844 980 0750**

Trade Installer Hotline: ☎ **0844 980 0730**

Fax: **0844 980 0744**

www.tritonshowers.co.uk

E-mail: serviceenquiries@tritonshowers.co.uk