

- Installation Performed By Qualified Personnel Only!  
- Clean Carefully The Water Pipes Before Installing The Tap.

**WARNING**

These taps are double flow. Water bylaws require that where the hot water is supplied from a tank and cold from the mains, non return valves are fitted on both hot and cold pipes as close as possible to the tap. These are not supplied. Where combination boilers are fitted it is only necessary to shut off the incoming mains and turn the boiler off and non return valves are not required.

**Preparation and bylaw requirements**

All products are manufactured using materials tested and approved under the Water Bylaws Scheme and comply with requirements of British Standard 5412:1996 where applicable.

**Approvals**

The warranty:  
- On receipt of this product the chrome finish must be checked for blemishes. Defects notified after fitting may be regarded as damage resulting from the installation process, incorrect maintenance or misuse and as a result not be claimable under the warranty.

- Standard specifications
1. Recommended working pressure: .....1 Bar
  2. Maximum test pressure: .....5 Bar
  3. Maximum hot water temperature: ..... 80°C
  4. We recommend installing filters (not supplied) to this product.
  5. Warning:

**General Installation Requirements**  
The installation must comply with regulations of the Local Water Authority as contained in their bylaws. All of the taps in this range are double flow (the hot and cold water are separated) and should therefore be supplied with hot and cold water at balanced pressures, both from the tank or both from the mains (via a combination boiler for example). If the taps are not supplied at balanced pressures then the tap will not function correctly. It will also be necessary to fit non-return valves on both hot and cold feeds. It is very important that all pipe work is flushed thoroughly after installation to avoid damaging the ceramic disc.

Please read these instructions carefully and keep in a safe place for future reference.

**INTRODUCTION**

**Wall mounted washbasin mixer**

**TO130WNC**

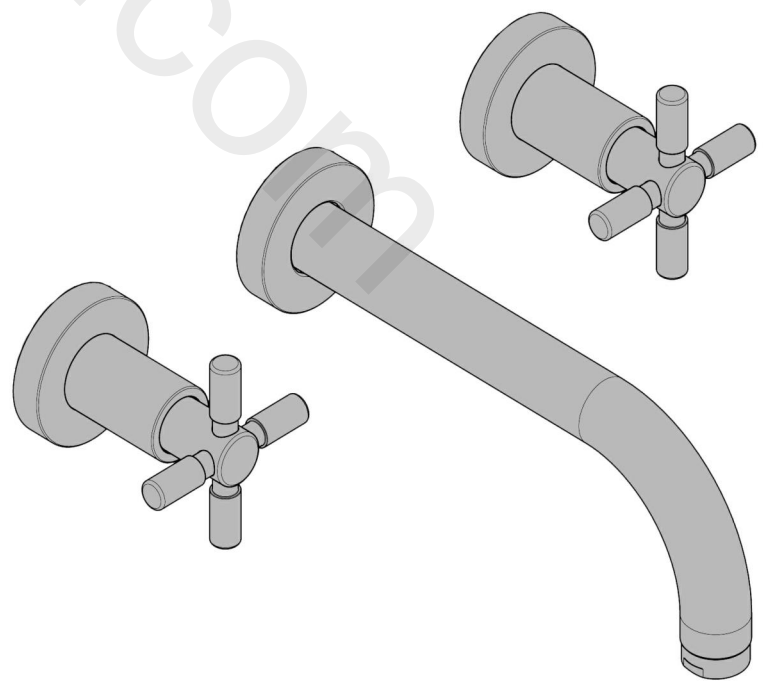

**INSTALLATION INSTRUCTIONS**

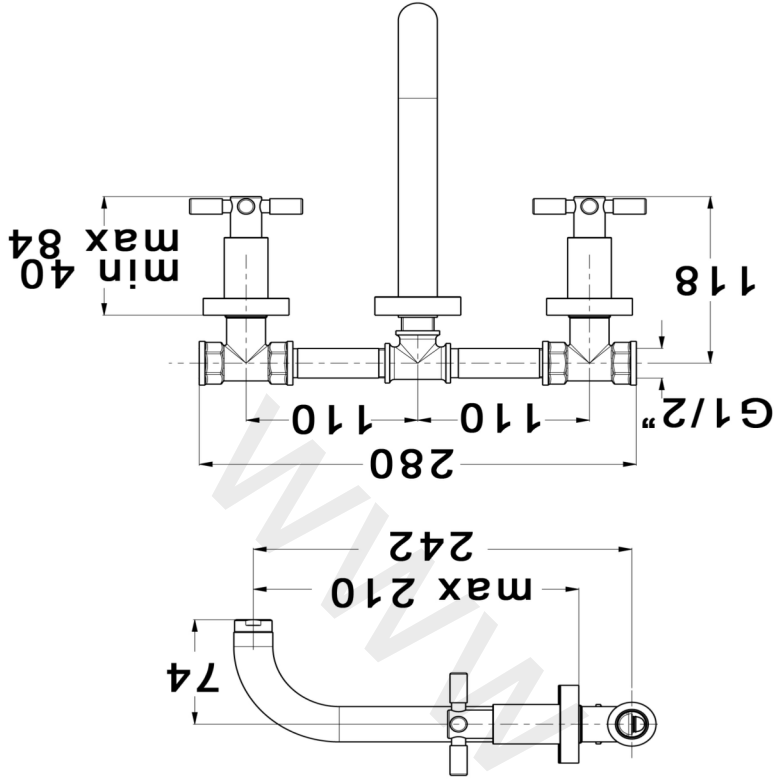

**TO130WNC**

**DIMENSIONS**

This product should only be fitted by a qualified plumber to NVQ (National Vocational Qualification) or SNVQ (Scottish National Vocational Qualification) Level 3. Should the installation be completed by a non-qualified person then the guarantee may be considered invalid.

For a claim made under our warranty written certification of your installers credentials can be required. For further information or to find a qualified installer in your area please visit the Institute of Plumbers website - [www.iphe.org.uk](http://www.iphe.org.uk).

**THE QUALIFICATIONS**

At present, to be a plumber you need to follow the National Vocational Qualification (NVQ) route (Scottish National Vocational Qualification - SNVQ - in Scotland). These qualifications are made up of theory and practical work in the classroom/purpose built training facility and work based experience with a working plumber. Colleges should help students find a work placement, although many students organise it themselves.

The S/NVQ qualification works in levels. All recently qualified plumbers should hold S/NVQ Level 2 as basic with Level 3 as the preferred level. Level 2 will give you the foundation you need for a career in plumbing and teach you domestic plumbing to a satisfactory level. Level 3 is more comprehensive and deals with domestic, commercial and industrial plumbing along with aspects such as gas - if you want to one day set up

your own business, this is the level to reach. The Institute of Plumbing and Heating Engineering, and the industry as a whole recommends that all plumbers reach a minimum of Level 3.

Reaching Level 3 has other advantages. The Institute runs a Master Plumber Certificate, which only those attaining Level 3 or equivalent can reach as long as they have the relevant experience as well. Those with S/NVQ Level 3 can (once in membership with the Institute for five years as a Member MIPHE) gain Engineering Technician EngTech status with the Engineering Council (UK).

## INSTALLATION

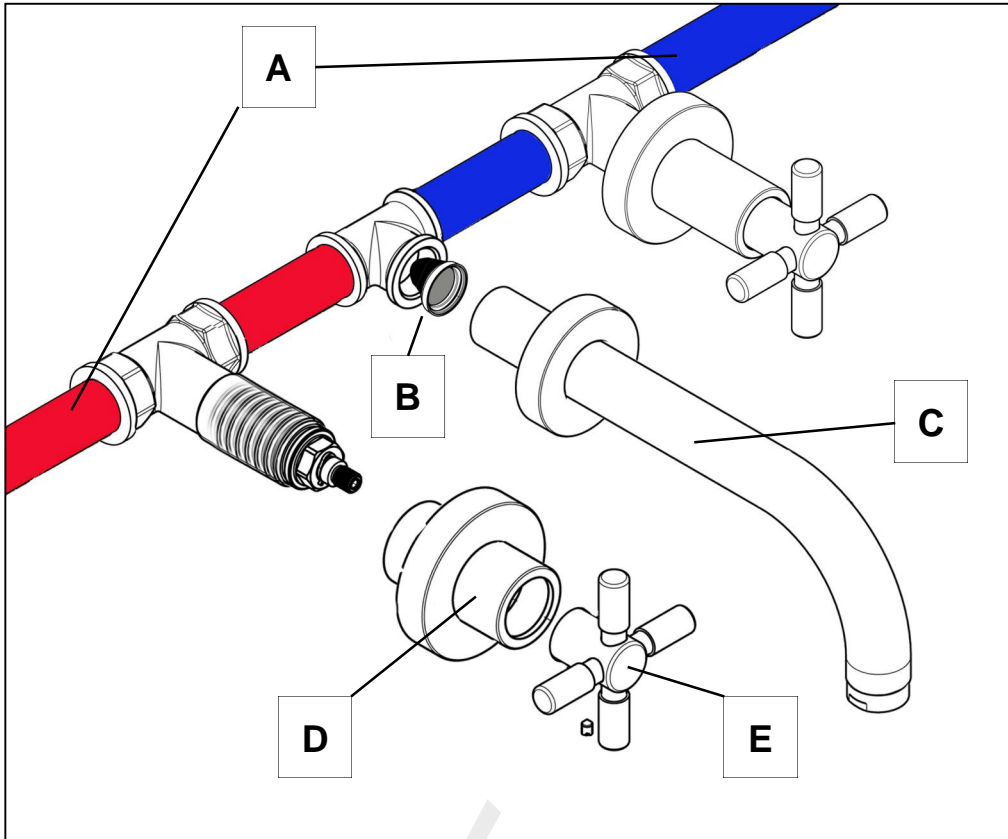

4

## INSTALLATION

TO130WNC

First shut off your water heating system then, with you remains stop cock closed, open the Lowest hot and cold taps in the house and allow to run until the cold storage tank and pipes are empty (the hot water storage cylinder airways remains full).

Where combination boilers are fitted it is only necessary to turn off the boiler and shut off the incoming mains.

Fitting isolating valves to the inlet feeds is recommended for ease of maintenance.



Remember to turn off the mains water supply before connecting to any existing pipe work. Flush the piping with plenty of water prior to installation.

### INSTALLATION

1. Decide on a suitable position for the tap where all users can operate; determine the route for the incoming cold-hot supply pipe work.
2. Mark an opening sufficient to accommodate the tap body, whose dimension like the template (page 3).
3. Install the hot and cold supply (A).

### SPOUT INTALLATION

4. When tiles have set, remove the plastic protection cover (B)
5. Insert the spout (C) into the concealing plate and screw it into the threaded junction pipe
6. Push the concealing plate against the wall the .

### HANDLES INTALLATION

7. Insert the under-handle cylinder (D) into the concealing plate and screw it into the threaded side assemblies valve.
8. Fit the lever (E) in place and secure it with the grub screw (F).

crosswater<sup>x</sup>

5

## MAINTENANCE

TO130WNC

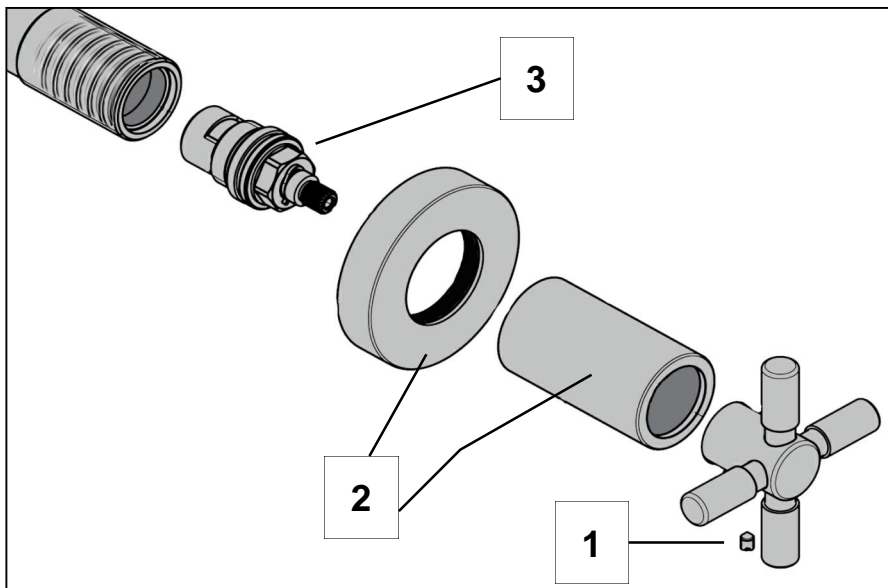

### CLEANING - REPLACE VALVE

The concealed valve should give trouble free service, but in the event of any problems, servicing is straight forward.

First shut off the water supply to the tap. With an allen key loosen the grub screw (1) in handle, but do not remove it. Unscrew the valve cover (2) and carefully using a correct size spanner, unscrew the valve (3). Wash the valve with clean running water and make sure that any trapped debris have been removed. Dry and lightly grease the seals (only use silicone grease) and restore the valve, retaining nut, valve cover followed by the handle.

6

## MIXER NOZZLES (Option)

All the taps are fitted with a flow straightener for use in low pressure installations. If your water is supplied at high pressure you may prefer to change the nozzle to an aerator To change the nozzle. Unscrew the nozzle from the mixer taking care not to loose the washer. Replace the washer, and screw on the chosen nozzle, hand tighten only.

FLOW STRAIGHTENER



AERATOR  
(not included in the package)

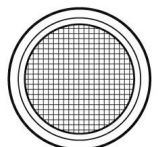

## CLEANING

The chrome plate we use on our taps is very durable, nevertheless care should be taken when cleaning them. They should be cleaned only with warm soapy water followed by rinsing with clean water and drying with a soft cloth. All finishes are vulnerable to acid attack and some strong substances such as household cleaners, disinfectants, denture cleaners, hair dyes, wine making and photographic chemicals can cause the surface to go black or peel.

crosswater<sup>x</sup>

7