

HERITAGE

BATHROOMS

Installation Instructions Lymington Extension Range

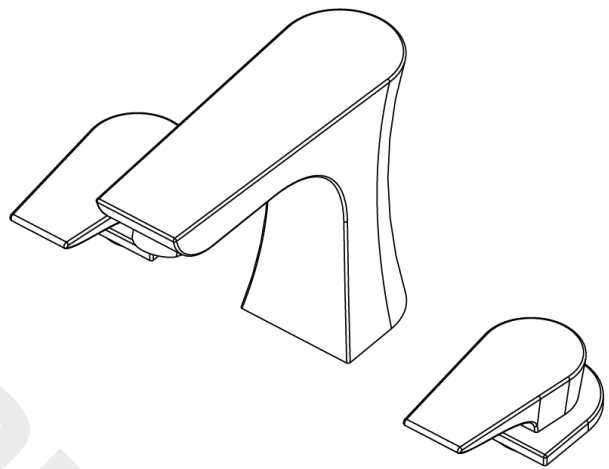

Models Covered:

TLYCG06, TLYCG073, TLYCG074

Please keep this booklet for future reference.

Installer: When you have read these instructions please ensure you leave them with the user.



Contents

When you purchase a Heritage product, you can be confident that it not only features a beautiful, distinctive, classical design, but also, that it has been made to the very highest quality standards.

To ensure that it works to its full potential, it needs to be fitted correctly.

These fitting instructions have been created to give you all of the information you need and if you need any further help, please do not hesitate to give us a call on 0844 701 8503.

Important Safety Information	03
General Specification	03
Dimensions	04-05
Installation	06-09
3 Hole Basin Mixer/ Bath Filler	06-07
5 Hole BSM	08-09
Maintenance	10-11
Troubleshooting	12-13
Notes	14
Guarantee	15

Important Safety Information

- Please read these instructions thoroughly and retain for future use.
- All products manufactured and supplied by Heritage are safe provided they are installed correctly, used correctly and receive regular maintenance in accordance with these instructions.
- **If you are in any doubt about your ability to install this product safely you must employ the services of an experienced qualified plumber.**
- Remove all packaging and check the components for damage before starting installation.
- ⚠ Before starting any installation please consider the following: Prior to drilling into walls, check that there are no hidden electrical wires, cables or water supply pipes. This can be checked with the aid of an electronic detector.
- If power tools are used do not forget to:
 - Wear eye protection
 - Unplug equipment after use
- This product must not be modified in any way as this will invalidate the guarantee
- These fittings need to be installed in accordance with and meet the requirements of the Water Supply (Water Fittings) Regulations 1999 and Scottish Byelaws 2004.

General Specification

Operating pressure range (bar)	Min	Max
3 Hole Basin Mixer	0.2	5.0
3 Hole Bath Filler	0.2	5.0
5 Hole Bath Shower Mixer	0.4	5.0

Maximum static pressure – 10.0 bar

NOTE:- Nominally equal (balanced) inlet supply pressures are recommended for optimum performance of mixer taps.

Designed to comply with BS EN 200 for single taps / combination taps for water systems of type 1 and 2 general technical specifications; and to be used within systems designed to BS 6700.

BS 6700 recommends the temperature of stored water should never exceed 65°C. A stored water temperature of 60°C is considered sufficient to meet all nominal requirements and will minimise the build up of lime scale in hard water areas.



Dimensions

3 Hole Basin Mixer

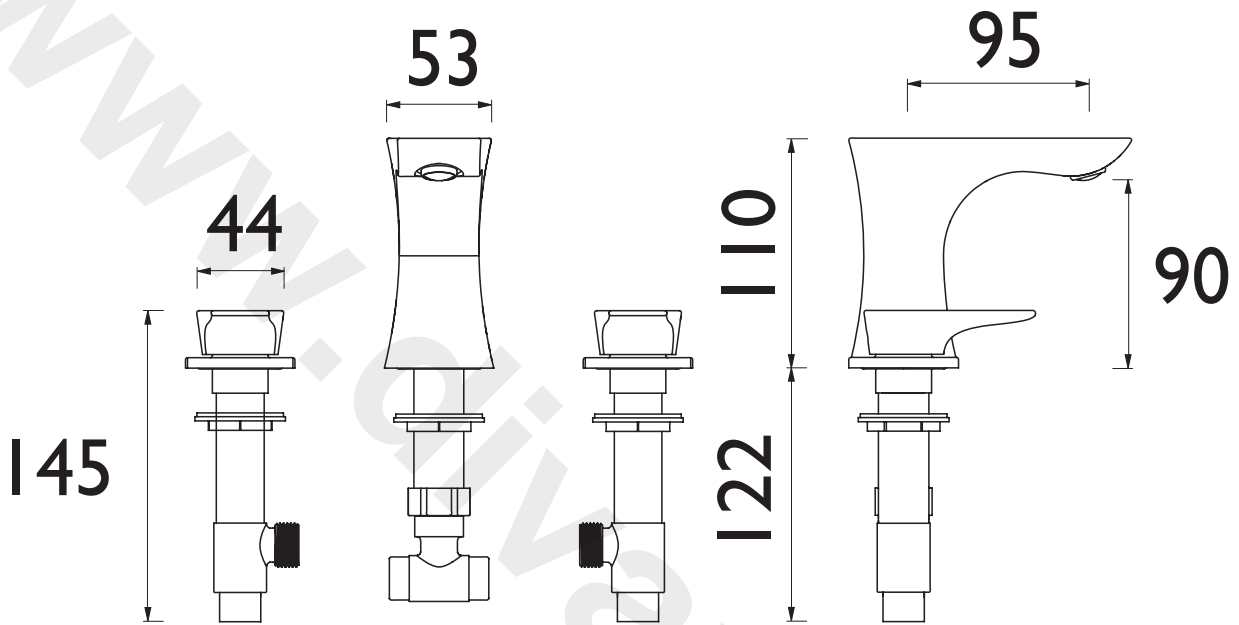

3 Hole Bath Filler

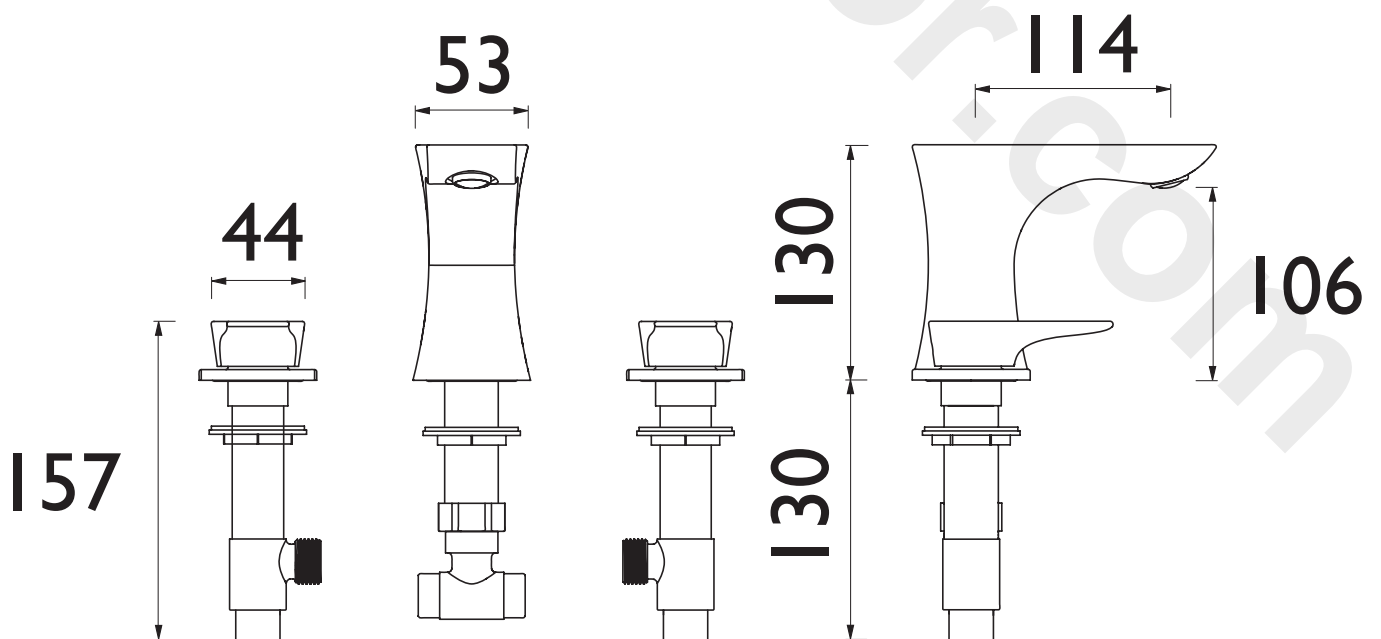

Dimensions

5 Hole Bath Shower Mixer

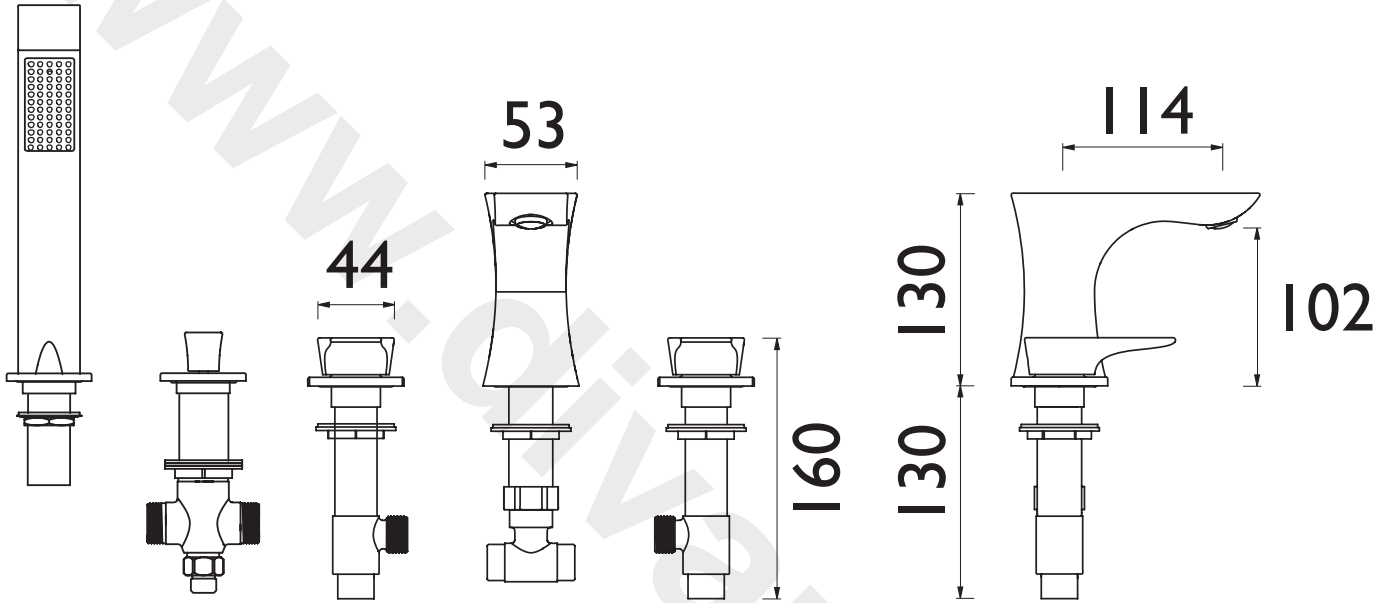



Installation- 3 Hole Basin Mixer/ Bath Filler

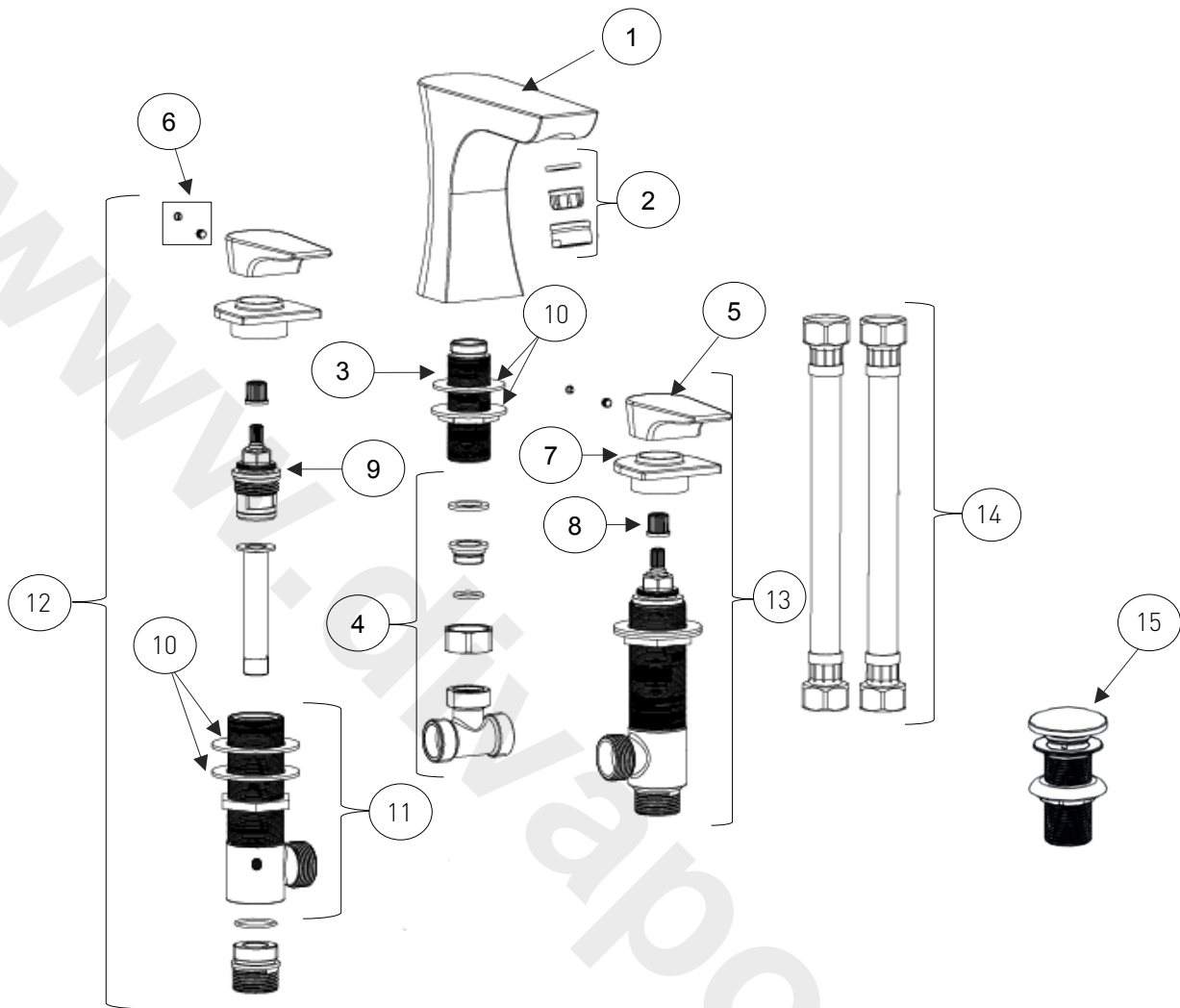

- | | |
|--|----|
| 1. Spout | x1 |
| 2. Anti- splash Assembly | x1 |
| 3. Spout Threaded Tail | x1 |
| 4. T-joint Assembly | x1 |
| 5. Handle | x2 |
| 6. Cap & Grub Screw | x1 |
| 7. Plinth | x2 |
| 8. Spline adaptor | x2 |
| 9. Valve | x2 |
| 10. Washer & Backnut | x3 |
| 11. Side Body Threaded Tail | x2 |
| 12. Hot Tap Body Assembly | x1 |
| 13. Cold Tap Body Assembly | x1 |
| 14. Flexi tails | x2 |
| 15. Complete Clicker Waste
(supplied with Basin Mixer only) | x1 |

Installation- 3 Hole Basin Mixer/ Bath Filler

1. Identify all components are present prior to starting installation.
2. Unscrew the plinth (6) from threaded tail (11) to remove the handle (4).
3. Fit the side body threaded tails (11) to the underside of the basin and secure in place by screwing the plinth (6) and handle (5) back on to the threaded tails (11), and tighten the backnuts (10).
4. Unscrew the T-Joint assembly (4), washers and backnut (10) from the thread of the spout (1) and fit the spout (1) to the basin tightening the backnut (10).
5. Re-attach the T-joint assembly (4) and connect to the side bodies (11&12-hot on the left, cold on the right when viewed from the front), by using the desired length of 15/22mm copper pipe (not supplied) and compression fittings (not supplied).
6. Connect the hot and cold water supplies to the side bodies (hot to the left hand side), fully open both valves, letting them run for a few minutes to flush the system.
7. Fit the clicker waste (15) (basin mixer only) ensuring a rubber washer is fitted between the basin and the waste. Use a pure silicon sealant where necessary. Place the other rubber washer under the basin and secure in place by tightening the backnut. In order to fill the basin, the button in the middle of the waste needs to be pressed down. To release the water, press the button again.
8. Check all joints and connections for leaks.



Installation- 5 Hole Bath Shower Mixer

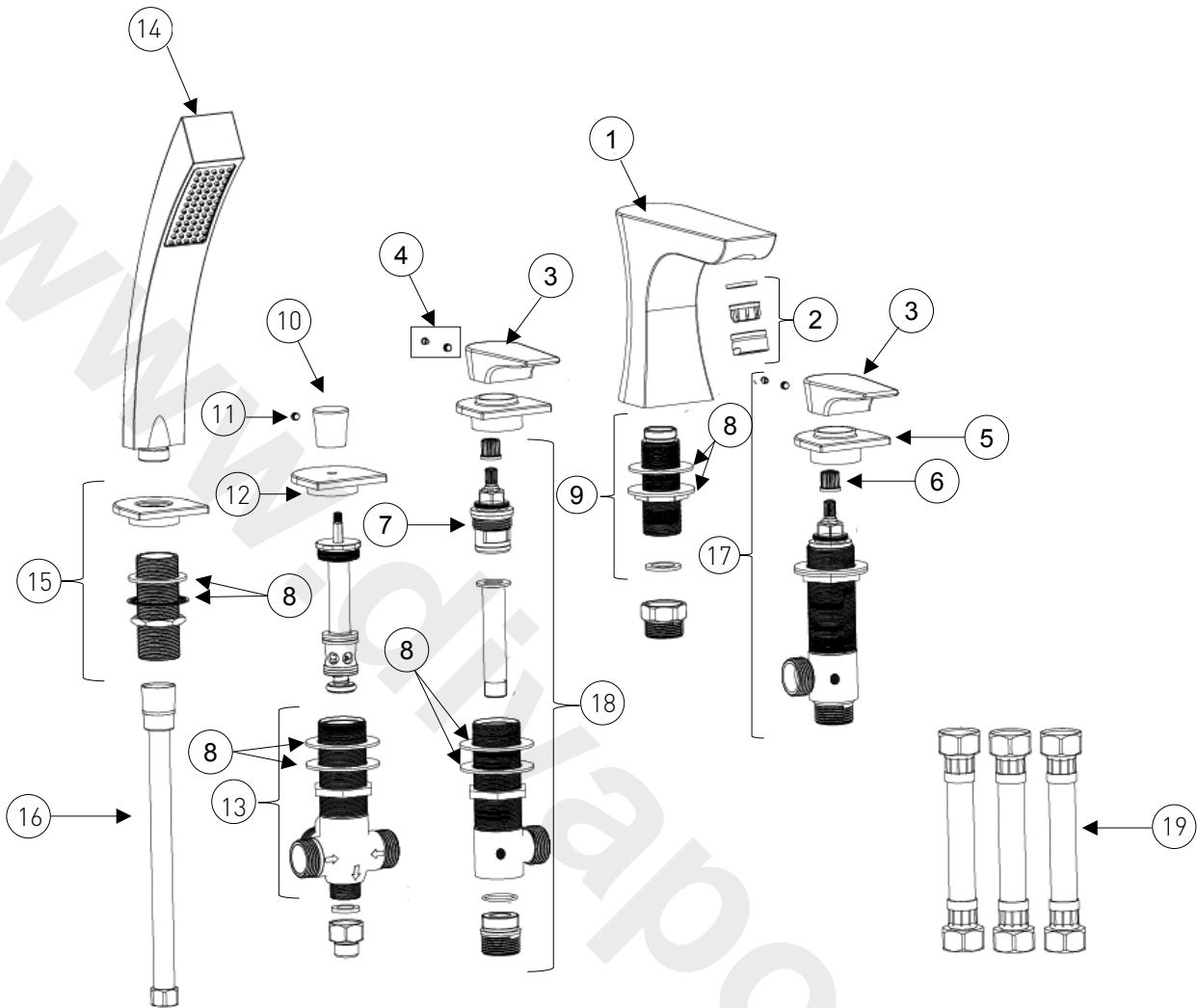

1. Spout	x1
2. Anti- Splash Assembly	x1
3. Handle	x2
4. Cap & Grub Screw	x2
5. Plinth	x2
6. Spline adaptor	x2
7. Valve	x2
8. Backnut & Washer	x4
9. Spout Threaded Tail	x1
10. Diverter knob	x1
11. Diverter Grub Screw	x1
12. Diverter Plinth	x1
13. T- joint assembly	x1
14. Handset	x1
15. Handset Connection	x1
16. Hose	x1
17. Cold Side Body Assembly	x1
18. Hot Side Body Assembly	x1
19. Flexi Tails	x3

Installation- 5 Hole Bath Shower Mixer

1. Identify all components are present prior to starting installation.
2. Remove the handles (3) from the side bodies (17 & 18) by removing the cap (4) and loosening the grub screw (4) at the rear of the handle (3).
3. Unscrew the plinths from the side bodies (5).
4. Fit the side bodies (17 & 18) to the bath from underneath and screw the plinths (5) onto the side bodies (17 & 18). Secure the side bodies by tightening the backnuts (8).
5. Fit the spout (1) to the bath secure by tightening the backnut (8).
6. Unscrew the diverter knob (10) and plinth (12) from the diverter and fit the diverter body to the bath. Re-fit the plinth (12) and diverter knob (10) and tighten backnut (8) to secure into position.
7. Fit the handset connection (15) to the bath and secure in place by tightening the backnut (8).
8. Connect the flexi hoses (19) from the side bodies (17 & 18) to the T-joint (13). The other flexi hose connects the T-joint (13) to the spout threaded tail (9).
9. Screw the shower hose (16) onto the handset (14) and thread the hose through the handset connection (15). Screw the hose (16) onto the back outlet of the T-joint (13).
10. Connect the water supply pipes to the side body threaded tails (17 & 18).
11. Turn on both, hot and cold taps letting the water flow for several minutes to flush the system and check for any leaks.
12. To switch from bath fill to shower mode pull the diverter knob (10) up. To revert back to bath fill mode, while in use, push the diverter back down. The bath shower mixer will automatically revert back to bath fill if turned off while in shower mode.



Maintenance

General Cleaning

Your fitting has a high quality finish and should be treated with care to preserve the visible surfaces. All finishes will wear if not cleaned correctly. The only safe way to clean your product is to wipe with a soft damp cloth. Stains can be removed using washing up liquid. All bathroom cleaning products (powders and liquids) will damage the surface of your fitting, even the non-scratch cleaners.

Note: Never use abrasive detergents or disinfectants or those containing alcohol, hydrochloric acid or phosphoric acid.

Cleaning the Showerhead – TLYCG074

Your Heritage showerhead has rub-clean nozzles for easy cleaning. Simply rub your fingers across the rubber spray jets regularly and before you turn the shower on to remove any scale or debris. The hardness of the water in your area will determine how often you should clean your showerhead. Build up of scale in particularly hard water areas combined with constant use means you may need to clean your showerhead once a week. To ensure continued performance the showerhead needs to be regularly descaled.

Cleaning the Valves:

If your fitting begins to leak the following should be carried out;

Isolate both hot and cold water supplies to the tap by either:

- Turning the water supply off at the mains stopcock
- Turning off the isolation valves to the tap.

1. Remove the cap at the rear of the handle to reveal the concealed grub screw.
2. Unscrew the grub screw and pull the handle upwards.
3. Unscrew the valve from inside of the side body using a suitable spanner.
4. Lift out the valve and clean thoroughly. Be sure to check and clean out the seating within the tap body/assembly.
5. If necessary replace the valve using parts supplied by Heritage only.
6. Place the valve back into the tap side body and tighten the valve nut using a suitable spanner.
7. Replace handle assembly push the handle onto the valve. Tighten the grub screw and push fit the cap.

Note: It may be necessary to tighten the backnut.

8. Turn on water supply and check for leaks.
9. Contact our helpline if problem persists.

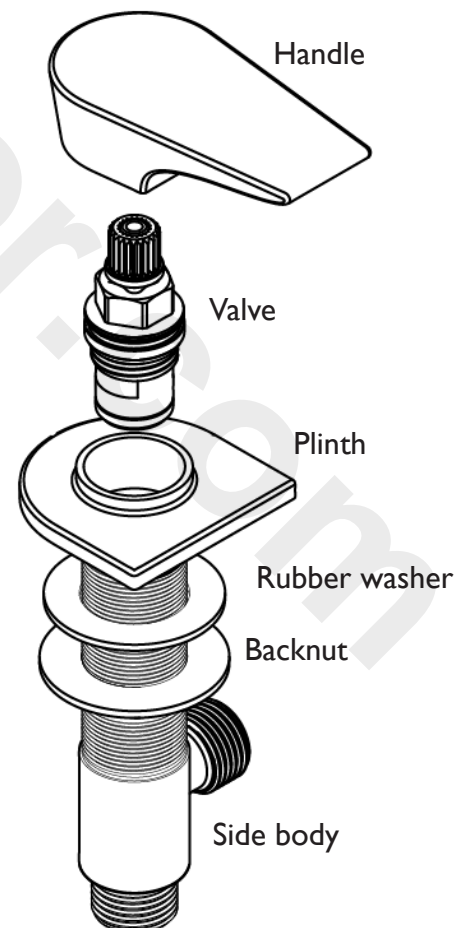

Maintenance

Cleaning the Cartridge:

If your fitting begins to leak the following should be carried out;

Isolate both hot and cold water supplies to the tap by either:

- Turning the water supply off at the mains stopcock
 - Turning off the isolation valves to the tap.
1. Remove the cap at the rear of the handle to reveal the concealed grub screw.
 2. Unscrew the grub screw and pull the handle upwards.
 3. Unscrew the shroud and cartridge retaining nut and pull the cartridge out from the body.
 4. Clean the cartridge thoroughly under cold water to remove any build up of limescale or debris.
If necessary replace the cartridge using parts supplied by Heritage only.
 5. Replace the cartridge into the body and tighten the retaining nut to secure in place.
 6. Screw the shroud onto the retaining nut and push the handle onto the cartridge. Tighten the grub screw and push fit the cap.
 7. Turn on water supply and check for leaks.
 8. Contact our helpline if problem persists.

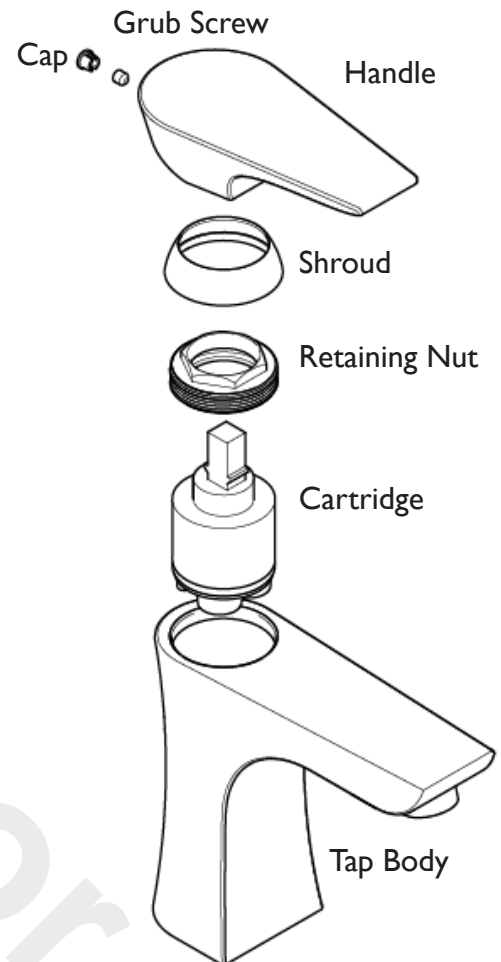



Troubleshooting

Symptom	Cause	Remedy
No flow or poor flow	Partially closed stop or service valve in water supply pipework to the tap.	Open stop or service valve.
	Head of water is below the minimum distance required.	Refer to the Specification section for minimum pressures required.
	Possible airlock / blockage in supply pipework	Remove water supplies from the fitting and flush the system to remove any airlocks / debris.
	Cartridge / Valve not opening fully.	Service fitting. Refer to maintenance section on pages 10-11.
Water dripping for a few seconds after the tap has been turned off.	This is caused by 'capillary action' and residual water in the spout being siphoned out.	This should only last for a couple of seconds.
Constant dripping / leaking when the tap is not in use.	Cartridge / Valve not fully shutting off.	Service fitting and replace cartridge. Refer to maintenance section on page 10-11.
Fitting does not turn on.	Water supplies not turned on.	Check that the water supplies to the fitting are turned on.
	Closed stop or service valve	Open stop or service valve.
Water does not come out of the showerhead when using the bath shower mixer.	Diverter mechanism not fully open.	Ensure diverter is pulled fully up.
	Insufficient water pressure / header height.	Refer to the specification section for minimum pressures required.

Heritage Bathrooms Guarantee

When you buy a Heritage product, you can be confident that it not only features distinctive design, but that it has also been made to meet our rigorous quality standards.

We offer robust guarantees and an attentive aftercare service to ensure that if you do experience any issues, we can deal with a problem quickly, and effectively,

Please note that guarantees are only valid with proof of purchase,

Our guarantees are as follows:



2 Years on
Mirrors & WC
Seats



5 Years on
Bath Screens,
Furniture,
Shower Valves,
Taps, Wastes,
Washstands &
Accessories



Lifetime Guarantees on Acrylic & Cast Iron Baths and Sanitaryware

Register now for additional peace of mind

Register your product with us now and, if you do have any queries after installation, we'll be able to quickly identify the product and give you the best advice. It also means that you won't have to keep your proof of purchase to validate your guarantee. To register, simply go on-line at www.heritagebathrooms.com/register

Guarantee Terms and Conditions

The guarantee is in addition to your statutory and other legal rights and is subject to the following conditions:

- The product was purchased within the United Kingdom or Republic of Ireland
- The product is used in domestic applications only
- The guarantee applies solely to the original purchaser with proof of purchase
- The installation must allow ready access to all products for the purpose of inspection, maintenance or replacement
- Repair under this guarantee does not extend the original expiry date. The guarantee on any replacement parts or product ends at the original expiry date

Any parts found to be defective during the guarantee period will be replaced without charge, providing that the product has been installed in accordance with the instructions given in this guide and used as the manufacturer intended. If the product is no longer available, Heritage will endeavour to provide the nearest equivalent.



Notes

Please use this space to add any notes you or your installer may have regarding plumbing system/ installation of this product.

www.divapor.com

Heritage Bathrooms Guarantee

The guarantee does not cover:

- Damage or defects caused by
 - General wear and tear (including special non-chrome finishes; components such as filters, seals, o-rings and washers)
 - Incorrect installation
 - Repair using non-Heritage parts
 - Accidental or wilful misuse
 - Corrosion and the use of inappropriate cleaning products
 - System debris including the build-up of limescale (which can be controlled through regular servicing and maintenance)
- Compensation for loss of use of the product or consequential loss of any kind

In the interests of continuous product improvement, Heritage reserves the right to alter product specifications without notice.

Need help?

In the unlikely event that you encounter a problem with your Heritage product, you must, in the first instance contact the retailer you purchased it from. They will advise as to whether it is due to a manufacturing fault or an installation fault. If the problem is due to a manufacturing fault, they will contact us to arrange a supply of a replacement product as soon as possible. To speak to a Heritage customer service advisor, please contact our technical helpline on **0844 701 8503**.



HERITAGE®
BATHROOMS

Heritage Bathrooms
Birch Coppice Business Park
Dordon
Tamworth
B78 1SG

Website: www.heritagebathrooms.com

Telephone: 0844 701 8503

Email: technical@heritagebathrooms.com

Lymington Ext - DI

