

shower valves - Telo Thermostatic Bath Shower Mixer

gives you
total control
showering

Introduction

The popular style of the Telo range ensures that it is at home in whatever setting it is installed. A flagship product of the Inta range, the Telo has proven itself time and time again to be a popular choice.

- Suitable for use with unvented supplies, combi boilers, gravity and mains pressure systems
- Thermal cartridge technology
- Temperature stability of +/-2°C
- Fail safe on hot and cold supplies
- Operating pressure range of 0.2 to 5 bar
- Integrated flow diverter
- WRAS and TMV2 approved



TL30014CP

TL30024CP

Product Range

Description	Code
telo thermostatic bath shower mixer with flexible slide rail kit	TL30014CP
telo thermostatic bath shower mixer with flexible slide rail kit and deck mounting legs	TL30024CP



shower valves - Telo Thermostatic Bath Shower Mixer

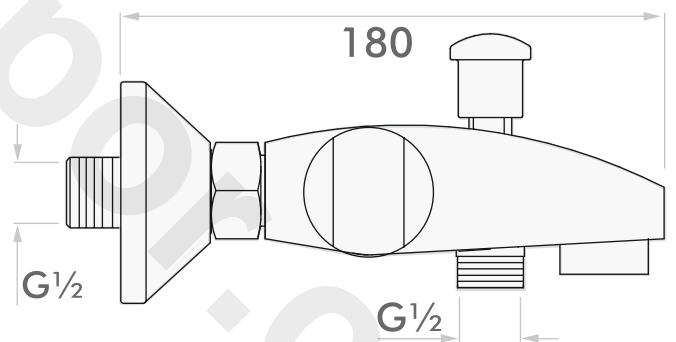
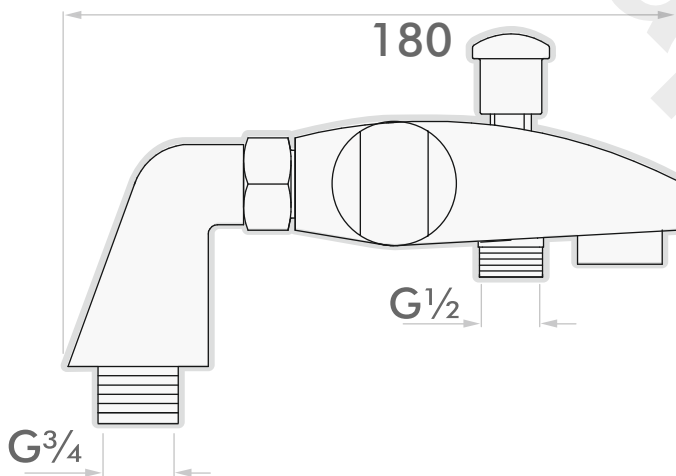
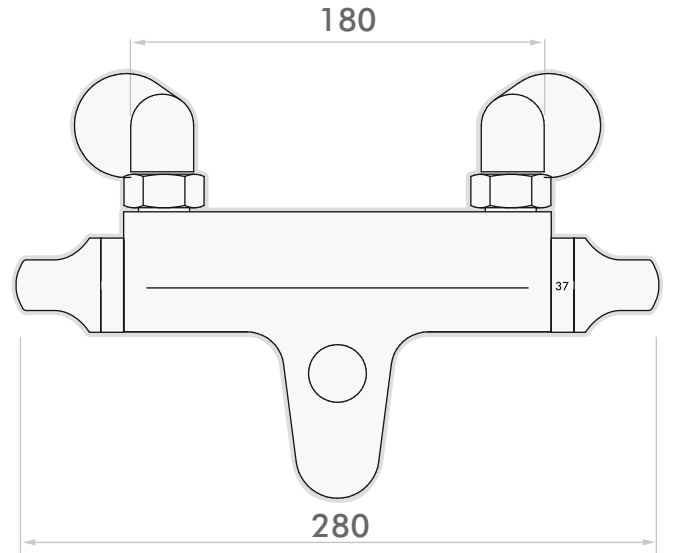
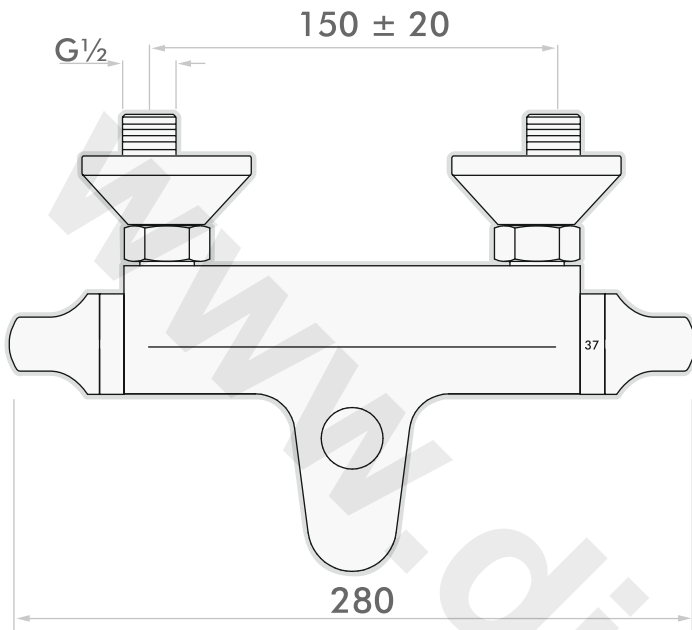

shower valves - Telo Thermostatic Bath Shower Mixer

Features

Technical Specification

Max Inlet Pressure static	5 Bar
Min Inlet Pressure dynamic	0.2 Bar
Max Inlet Temperature	85°C
Factory Pre-set Temperature	38°C with max temp stop
Inlet Connections	G 3/4" F BSP (valve body)
Outlet Connections	G 1/2" F BSP
Min Temperature to achieve hot or cold failsafe	15°C
System Installation	Unvented, Pressurised, Gravity and Combination Boilers

