

BRISTAN

Target Monobloc Kitchen Mixer Chrome

Installation Instructions & User Guide



Please keep these instructions for future reference and request of replacement parts

BRISTAN

Contents

Thank you for choosing Bristan, the UK's leading taps and showers expert. We have designed this product with your enjoyment in mind. To ensure that it works to its full potential, it needs to be fitted correctly. These fitting instructions have been created to give you all of the information you need and, if you need any further help, please do not hesitate to give us a call on 0844 701 6273.

Important Safety Information	03
Dimensions	04
General Specifications	05
Installation Requirements	05
Installation	06-07
Operation	08
Maintenance	08
Troubleshooting	09
Guarantee	10
Installation Notes	11

Important Safety Information

- Please read these instructions thoroughly and retain for future use.
- All products manufactured and supplied by Bristan are safe provided they are installed correctly, used correctly and receive regular maintenance in accordance with these instructions.
- **If you are in any doubt about your ability to install this product safely you must employ the services of an experienced qualified plumber.**
- Remove all packaging and check the components for damage before starting installation.
- ⚠ Before starting any installation please consider the following: Prior to drilling into walls, check that there are no hidden electrical wires, cables or water supply pipes. This can be checked with the aid of an electronic detector.
- If power tools are used do not forget to:
 - Wear eye protection
 - Unplug equipment after use
- This product **must** not be modified in any way as this will invalidate the guarantee.
- These fittings need to be installed in accordance with and meet the requirements of the Water Supply (Water Fittings) Regulations 1999 and Scottish Byelaws 2004.

Warning from your water Supplier

- **It could be a criminal offence to use this tap with a mains water supply drawn directly from the supply pipe.**
- (The supply pipe is the one which brings the water supply into your home and is directly connected to the public water main).
- This tap has an outlet on a flexible hose which, if immersed in water, could result in contaminated water being drawn back into the pipework if the supply pressure dropped. To prevent contamination of drinking water in the premises and in the water main, and to comply with the legal requirement of the UK plumbing regulations and byelaws*, **both hot and cold water supplied to this tap must come from a storage cistern.**
- If the distributing pipes feeding this tap from the storage cistern have other outlets connected to them, the outlet of this tap must be lower than any of those other outlets.
- If installed as a tap which is used for drawing water for drinking, and the quality of water from the storage cistern does not meet the standards for drinking water, a separate tap supplied with wholesome water must be provided for drinking purposes.
- For further information, contact the Water Regulations department of your local Water Supplier (see WRAS website www.wras.co.uk or Yellow Pages for details) or the Water Regulations Advisory Scheme by e-mail (info@wras.co.uk) or telephone: 01495 248454.
- The Water Supply (Water Fittings) Regulation 1999 in England and Wales; The Scottish Water Byelaws 2004 and Northern Ireland Regulations.

BRISTAN

Dimensions

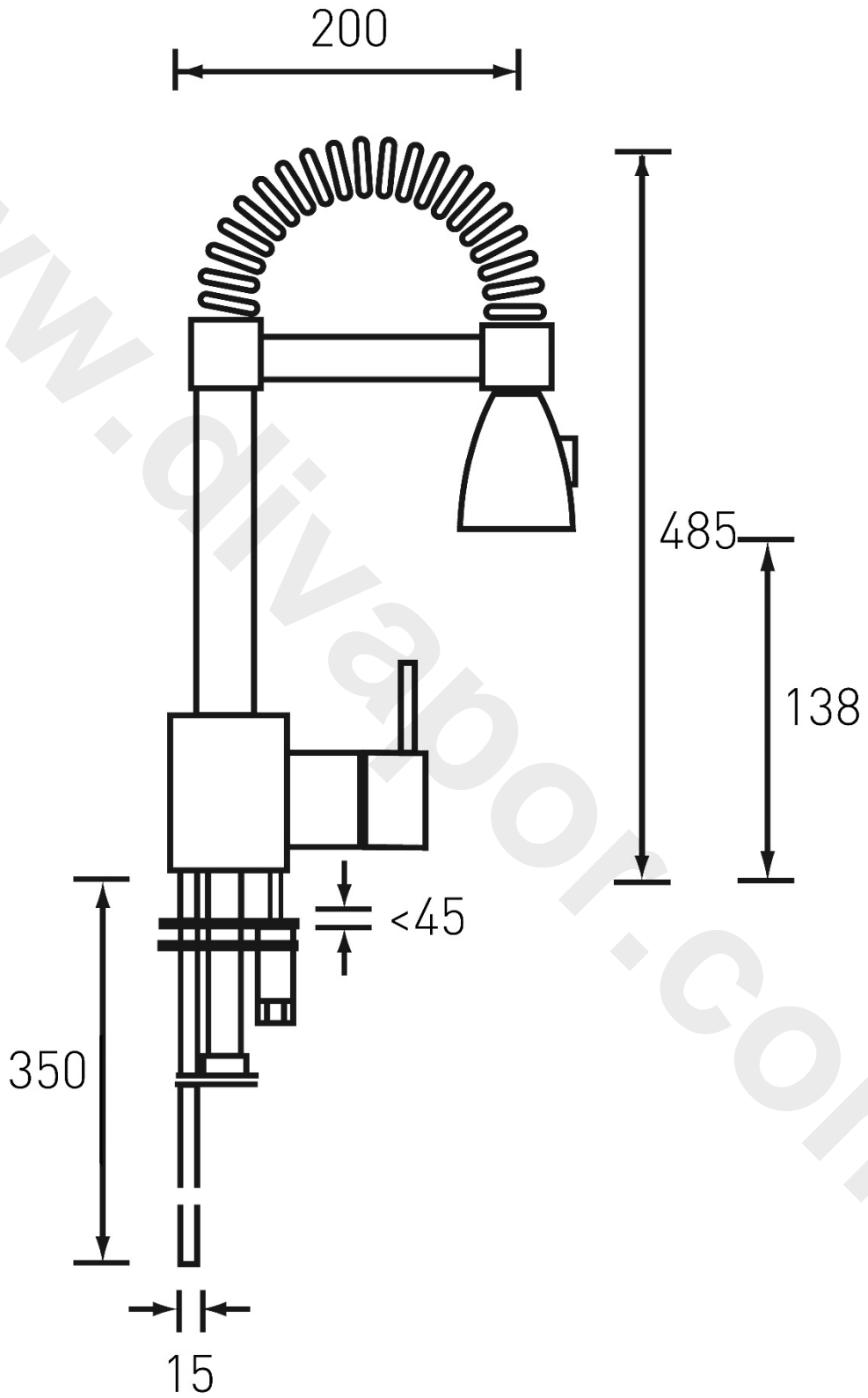

General Specifications

Operating pressure range (bar)	Min	Max
	1.0	8.0

Maximum static pressure – 10.0 bar

NOTE:- Nominally equal (balanced) inlet supply pressures are recommended for optimum Performance of mixer taps.

BS 6700 recommends the temperature of stored water should never exceed 65°C. A stored water temperature of 60°C is considered sufficient to meet all nominal requirements and will minimise the build up of lime scale in hard water areas.

Installation Requirements.

This fitting needs to be installed in accordance with the following Installation Requirements and Notes (IRN) to ensure they meet the requirements of the Water Supply (Water Fittings) Regulations 1999 and the Scottish Byelaws 2004. For further details contact your Local Water Authority.

For backflow protection in premises or installations up to fluid category 5.

The vertical distance of the outlet above the spill-over level shall be not less than 20 mm or twice the diameter of the inlet pipe to the fitting, whichever is the greater. If the fitting cannot be installed as indicated it shall be installed:-

- a) With a backflow prevention arrangement suitable for the Fluid Category or
- b) So that it draws water by gravity only from a cistern, cylinder or tank having a permanently open vent pipe, the vertical distance between the point at which the pipe or pipes supply water to the fittings is or are connected to the supply and the spill-over level of any fixed appliances is not less than the dimensions stated above, and the vent pipe or pipes supply(ies) no other fittings (other than a draining tap) at a lower level.

It is essential that all pipe work is flushed through to remove debris and swarf that could otherwise damage the fitting. Once the pipe work has been flushed through, turn off the water supply at the stop valve.

Important: Independent stop valves complying with the current water regulations should be fitted as a means of isolating both water supplies to the fitting for servicing and/or maintenance work.

Installation.

Identify all components are present prior to starting installation:

No.	Part
1	Pull-Out Head
2	Pull-Out Hose*
3	Spout Assembly including Fixation Cover*
4	M5x5 Grub Screw*
5	Holding Arm*
6	Arm Connection Piece*
7	Sealing Washers*
8	M4x4 Grub Screw*
9	35mm Flat Cartridge*
10	Cartridge Retaining Nut*
11	Shroud*
12	Handle Assembly including Cap & Grub Screw*
13	Copper Tails (Pair)*
14	Reinforcing Plate
15	Hose Weight
16	Plinth & Washer
17	Fixing Kit
18	Flexible Tails (Pair)
19	Check Valves (Pair)
20	White Protective Tube
21	Black Protective Tube (Not Shown)

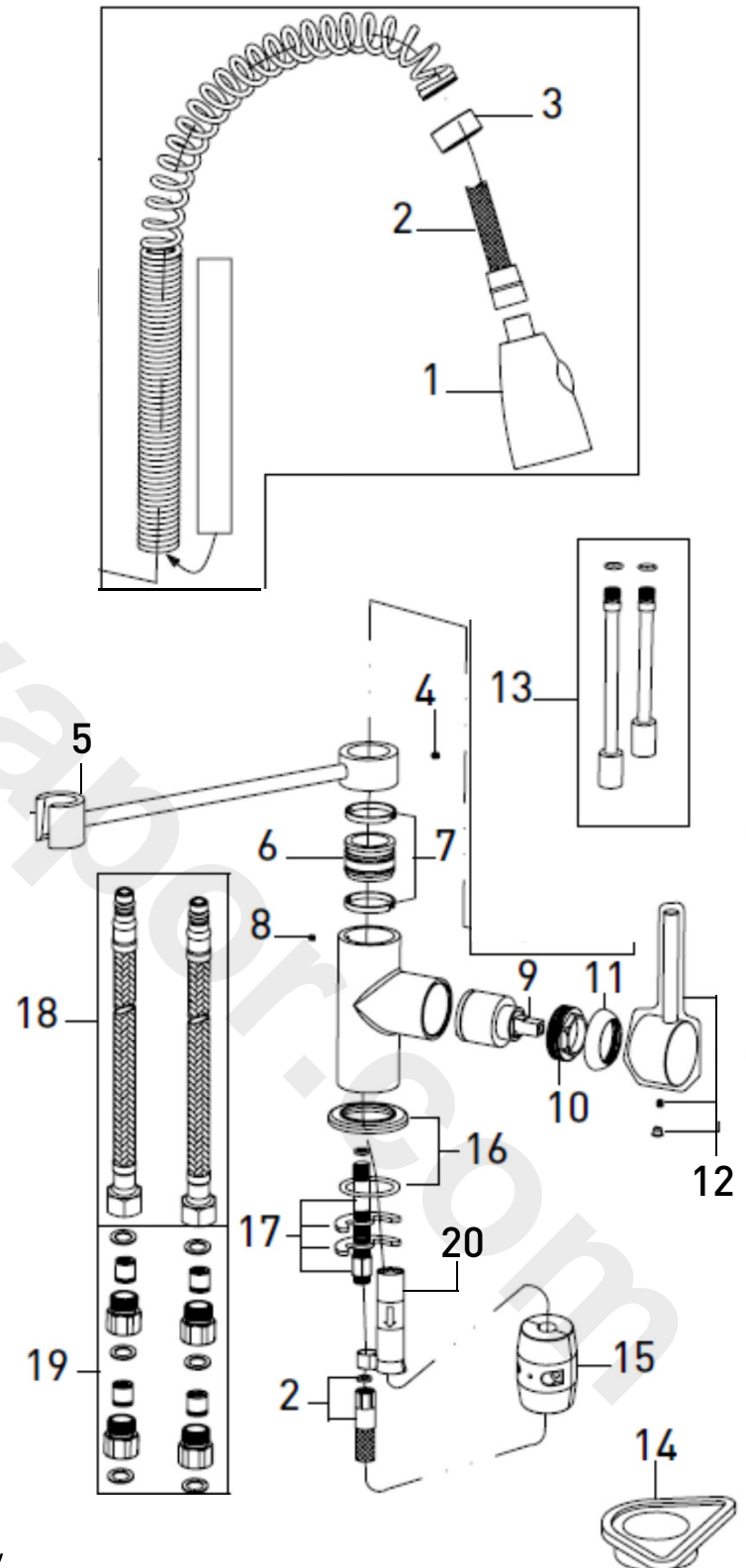

* Parts pre-assembled in box as part of tap body

Installation cont.

1. Fit the tap body to the sink by putting the plinth and washer in position and securing it by fixing the Reinforcing Plate underneath the sink. Place the tap body on top of the plinth.
2. Using the Fixing Kit, thread the fixing C-rubber washer and C-plate rubber washer onto the threaded rod, securing in position with the nut. Screw the spray nozzle on to the hose.
3. Feed the hose through the black protective tube, cut-out side towards you. Next, feed the white protective tube, arrows pointing towards you and attach the tube to the threaded rod.
4. Feed the hose weight on to the hose and connect it to the threaded rod, with the red washer sealing it.
5. Fit the flexible tails to the copper tails and attach the check valves to both of the inlets. Then connect the hot and cold supplies.
6. Fully open the cartridge letting it run for a few minutes and check all joints for leaks.

Flexible Connecting Tails:

Care must be taken when connecting the flexible connection pipes to the household pipework to ensure they do not bend sharply and kink or twist.

See below for recommended ways to fit the flexible connecting pipes

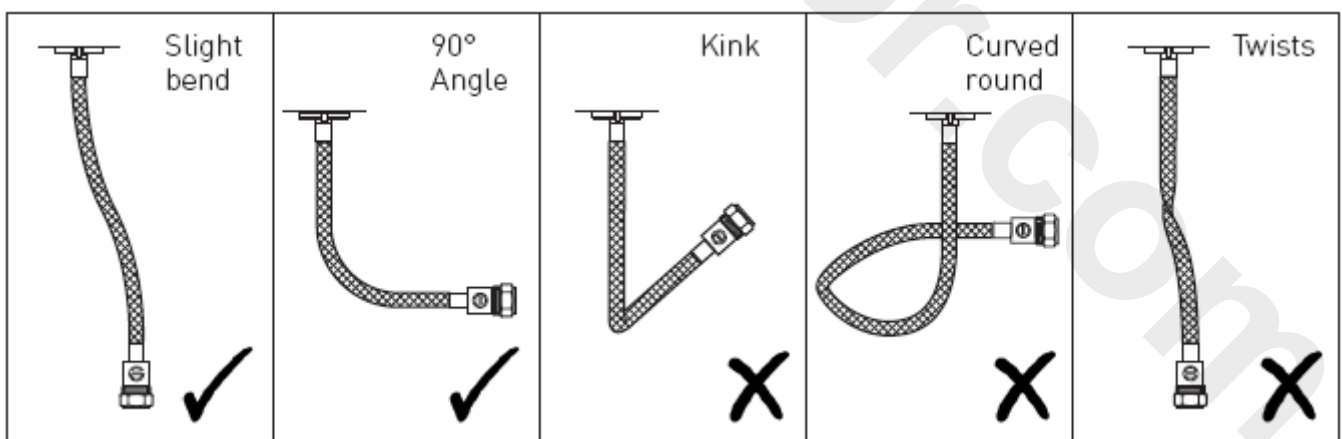

Important: Failure to follow these guidelines may result in poor performance and damage to the flexible connecting pipes

Operation

Pulling/pushing the lever backwards/forwards from the mixer body will turn on/off and increase/decrease the flow of water.

Moving the lever either to the left or right when in the backwards position (when the mixer is viewed from the front) will increase/decrease the water temperature.

The pull out handset incorporates a push button enabling the water flow to be altered from an inner water stream to a wider outer spray pattern.

Troubleshooting

Symptom	Cause	Remedy
No flow or poor flow rate.	Partially closed stop or service valve in water supply pipework to the tap.	Open stop or service valve.
	Head of water is below the minimum distance required.	Refer to the Specification section for minimum pressures required.
	Possible airlock / blockage in supply pipework	Remove water supplies from the fitting and flush the system to remove any airlocks / debris.
	Cartridge / Valve not opening fully.	Service fitting. Refer to maintenance section on page 09
Water dripping for a few seconds after the tap has been turned off.	This is caused by 'capillary action' and residual water in the spout being siphoned out. This should only last for a couple of seconds.	
Constant dripping / leaking when the tap is not in use.	Cartridge / Valve not fully shutting off.	Service fitting and replace cartridge / valve. Refer to maintenance section on page 09
Fitting does not turn on.	Water supplies not turned on.	Check that the water supplies to the fitting are turned on.
	Closed stop or service valve.	Open stop or service valve.

Bristan Guarantee

Bristan offers solid guarantees to provide you with complete peace of mind.

Taps and Mixers

5 year parts and 1 year labour*. Gold, painted and special finishes 3 years parts only.

All subject to proof of purchase.

Mixer Shower Valves

5 year parts. 5 year labour* (subject to registration), or 1 year with proof of purchase.

Gold, painted and special finishes 3 years parts only.

Pumps and Power Showers

2 year parts. 1 year labour* (subject to registration).

Electric Showers/Instantaneous Water Heaters

2 year parts. 1 year labour* (subject to registration).

Accessories

5 year parts only. Includes bathrooms accessories, shower accessories (e.g. hoses, handsets and poles), wastes, WC levers and light pulls. Gold, painted and special finishes 3 years parts only.

Sanitaryware

5 year parts only. Subject to proof of purchase.

*Labour provided by an approved Bristan engineer. Guarantee only applies to products with a manufacturing fault. A deferred payment will be necessary in order to secure any visits by our engineers which will be charged if the problem is found **not** to be a manufacturing fault. If the fault is found to be down to a manufacturing error, the payment will be released and not charged.

This guarantee applies to products purchased within the United Kingdom or Republic of Ireland, but does not apply to products used commercially.

The guarantee is only available to original purchasers who have proof of purchase.

The installation must allow ready access to all products for the purpose of inspection, maintenance or replacement.

Any part found to be defective during the above guarantee period will be replaced without charge, providing that the product has been installed in accordance with the instructions, used as intended, and regularly serviced.

Servicing should be carried out at regular intervals of no more than 12 months and more frequently in hard water areas (heavy lime scale) areas.

In the unlikely event that any problems are encountered with the product's performance on installation, you must obtain guidance/authorisation from our Customer Service Department, and be able to supply proof and date of purchase, before any remedial action is taken.

The guarantee excludes general wear and tear and damage caused by accident, misuse or neglect, and does not cover the following:

- Components that are subject to general wear and tear such as filters, seals, 'O' rings and washers etc.
- Damage caused by faulty installation
- Damage caused by lime scale or any waterborne debris
- Damage caused by inappropriate cleaning products (see user instructions)
- Damage caused by the use of non-Bristan parts
- The product being used for a purpose other than intended by the manufacturer.

In the interests of continuous product improvement Bristan reserves the right to alter specification as necessary.



Guarantee

Maintenance

General Cleaning

Your fitting has a high quality finish and should be treated with care to preserve the visible surfaces. All finishes will wear if not cleaned correctly. The only safe way to clean your product is to wipe with a soft damp cloth. Stains can be removed using washing up liquid. All bathroom cleaning products (powders and liquids) will damage the surface of your fitting, even the non-scratch cleaners.

Note: Never use abrasive detergents or disinfectants or those containing alcohol, hydrochloric acid or phosphoric acid.

If the fitting begins to drip:

1. Isolate both water supplies.
2. Remove cap (16) and remove grub screw (15) below with a 2.5mm hexagonal key.
3. Remove the handle (14), shroud (13) and brass retaining nut (12) and pull out the cartridge (11) complete with seal.
4. Clean or replace cartridge, clean and grease seal and refit.

Note: That there are locating pins on the bottom of the cartridge that fits in holes inside the tap, to ensure it is fitted the right way round.

5. Refit brass retaining nut and reassemble lever.
6. If problem persists, contact our help line quoting the product code TG SNK C.

Notes:

www.divapor.com

BRISTAN

This booklet covers product code:

TG SNK C

Helpline

0844 701 6273

Bristan Group Limited

Birch Coppice Business Park, Dordon, Tamworth, Staffordshire B78 1SG

A Masco Company

Website: www.bristan.com

Telephone: 0844 701 6274 Facsimile: 0844 701 6275

Email: enquire@bristan.com