

HERITAGE®

BATHROOMS

Dawlish Tap Range Installation Instructions and User Guide

Models covered:

TDCC00 / TDCG00	Basin Taps
TDCCS00 / TDCGS00	Short Nose Basin Taps
TDCC01 / TDCG01	Bath Taps
TDCC072 / TDCG072	Bath Filler
TDCC02 / TDCG02	Bath Shower Mixer

Please keep this booklet for future reference.

Installer: when you have read these instructions please ensure you leave them with the user.

Contents

When you buy a Heritage product, you can be confident that it not only features a beautiful, distinctive, classic design, but that it has also been made to the very highest quality standards. To ensure that it works to its full potential, it needs to be fitted correctly.

These fitting instructions have been created to give you all of the information you need and, if you need any further help, please do not hesitate to give us a call on **0844 701 8503**.

Important Safety Information	02
General Specifications	02
Dimensions	03-04
Installation	05-07
Basin Taps & Bath Taps	05
Bath Filler / Bath Shower Mixer	06-07
Maintenance	08-09
Map Of Hard Water Regions	10
Troubleshooting	11
Guarantee	12-13
Notes	14





Safety Note

- Please read these instructions & retain for future use. All products manufactured & supplied by Heritage are safe, provided they are installed correctly, used correctly, and receive regular maintenance in accordance with these instructions.
- **If you are in any doubt about your ability to install this product safely you must employ the services of an experienced, qualified plumber.**



Before starting any installation project please consider the following:

- Prior to drilling into walls, check there are no hidden electrical wires or cables or water supply pipes with the aid of an electrical detector.
- If you use power tools do not forget:
 - Wear eye protection.
 - Unplug equipment after use.
- This product must not be modified in any way as this will invalidate the guarantee.
- These fittings need to be installed in accordance with and meet the requirements of the Water Supply (Water Fittings) Regulations 1999 and Scottish Byelaws 2004.

General Specifications

Operating pressure range (bar)	Min	Max
½" Basin Taps	0.1	5.0
¾" Bath Taps	0.2	5.0
Bath Filler	0.2	5.0
Bath Shower Mixer	0.2	5.0

Maximum Static Pressure – 10.0 bar

NOTE:- Nominally equal (balanced) inlet supply pressures are recommended for optimum Performance of mixer taps.

Designed to comply with BS EN 200 for single taps / combination taps for water systems of type 1 and 2 general technical specifications; and to be used within systems designed to BS 6700.

BS 6700 recommends the temperature of stored water should never exceed 65°C. A stored water temperature of 60°C is considered sufficient to meet all nominal requirements and will minimise the build up of lime scale in hard water areas.



Dimensions

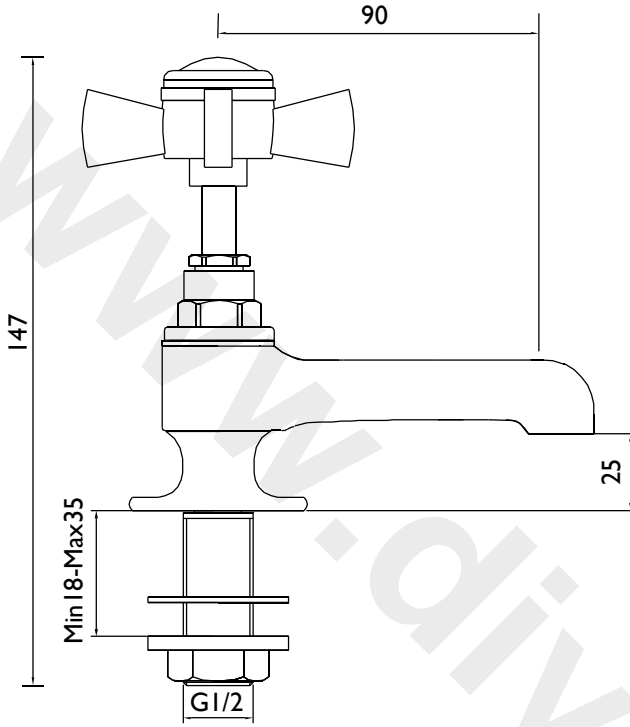

Basin Taps (TDCC00/TDCG00)

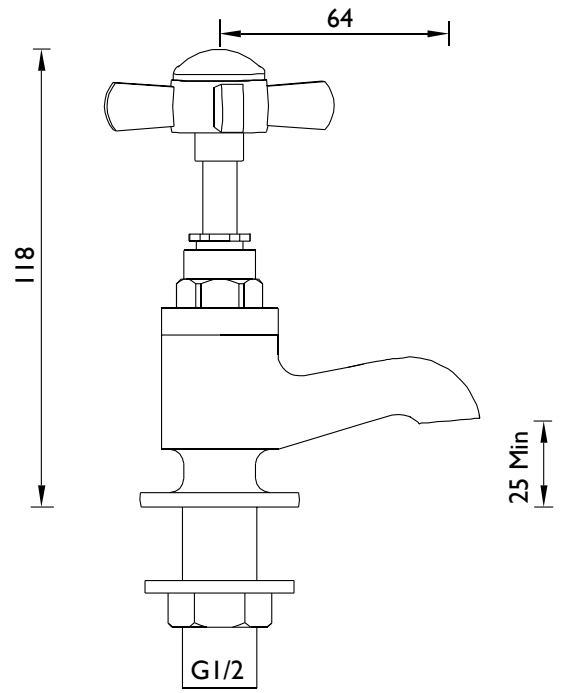

Short Nose Basin Taps (TDCCS00/TDCGS00)

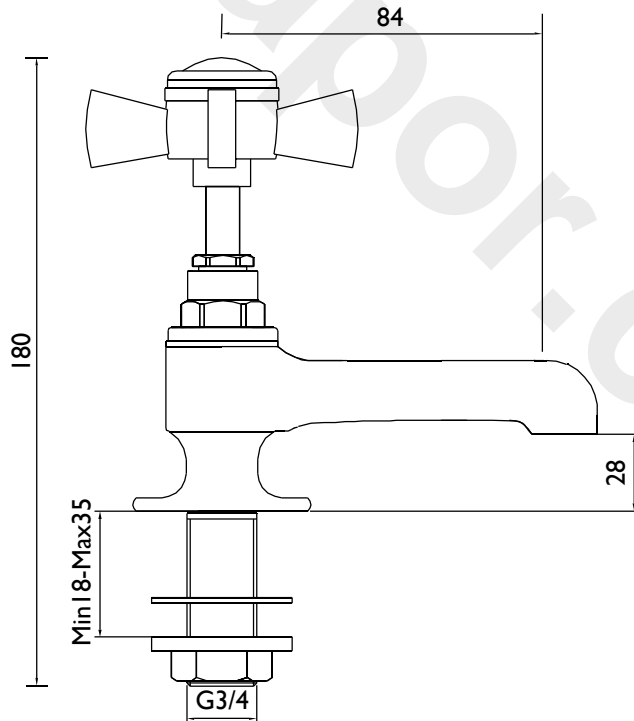

Bath Taps (TDCC01/TDCG01)





Dimensions Cont.

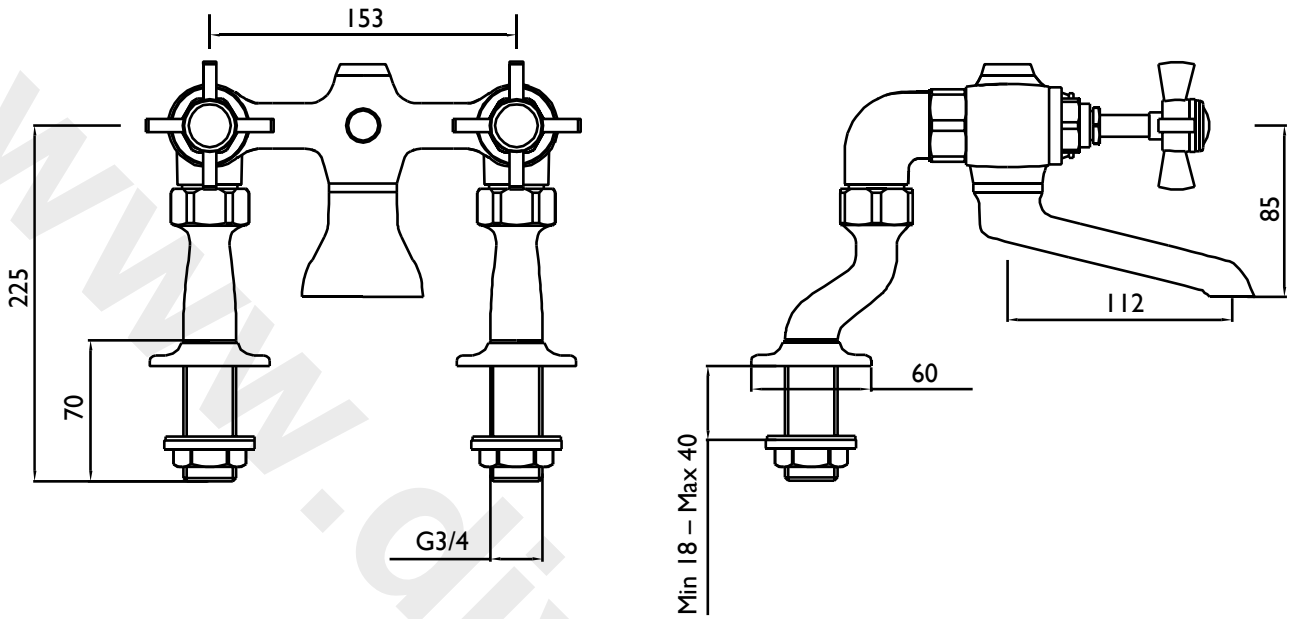

Bath Filler (TDCC072/TDCG072)

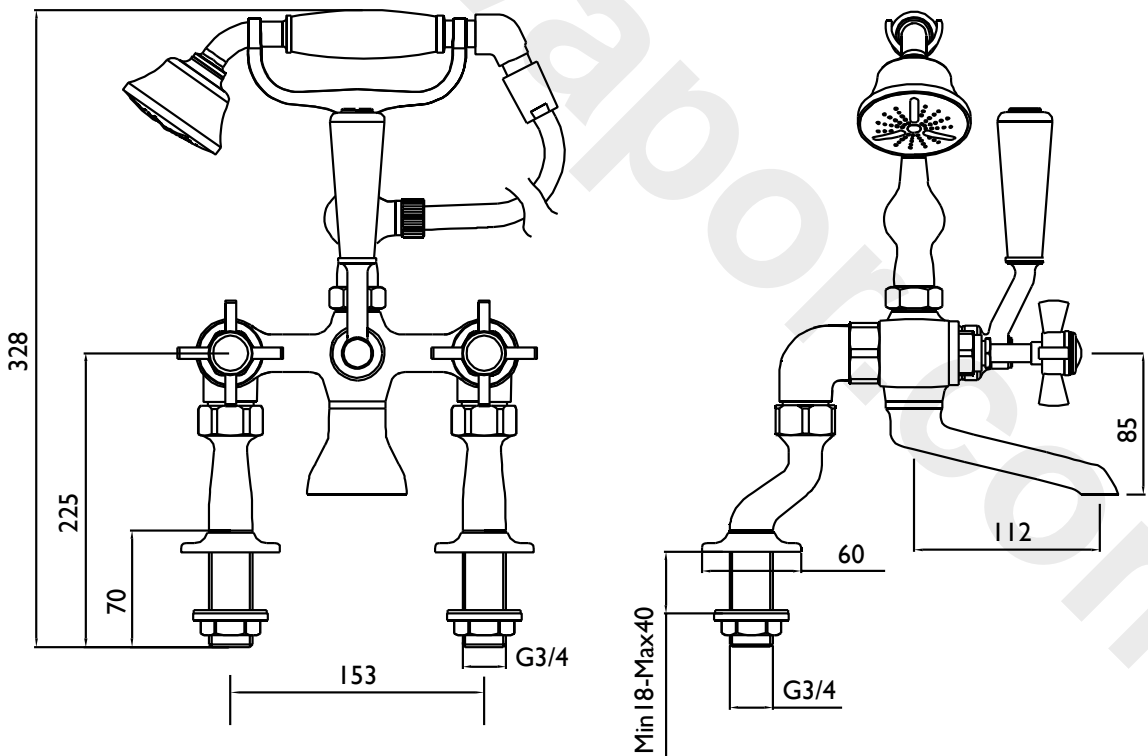

Bath Shower Mixer (TDCC02/TDCG02)



Installation

1. Identify all components are present prior to starting installation.
2. Using the washer (10) and backnuts (11) secure the taps to the basin by tightening the backnuts onto the pre-fitted threaded tails (9). A suitable spanner may be required to fully tighten the backnuts (11).
3. Connect the hot and cold water supplies to the connecting pipes
4. Turn on the water and fully open the mixer, allowing it to run for a few minutes and check all joints and connections for any leaks.

1.	Indice	x2
2.	Handle Screw	x2
3.	Metal Washer	x2
4.	Handle	x2
5.	Shroud	x2
6.	Valve	x2
7.	Washer	x2
8.	Tap Body*	x2
9.	Threaded Tail	x2
10.	Washer	x2
11.	Backnut	x2

*Tap body shown is for illustration purposes only. The installation process applies to all models listed for this booklet

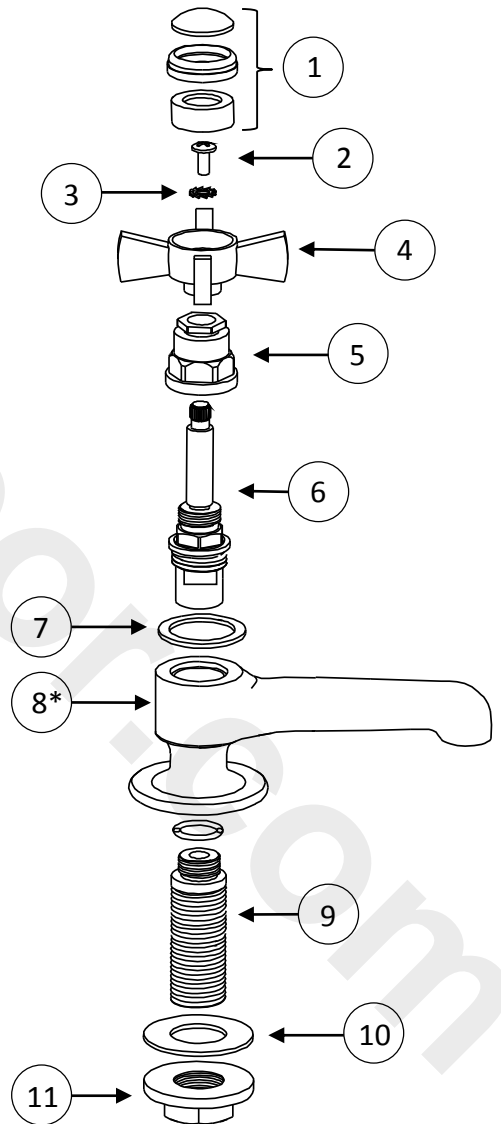



Installation – Bath Filler / Bath Shower Mixer

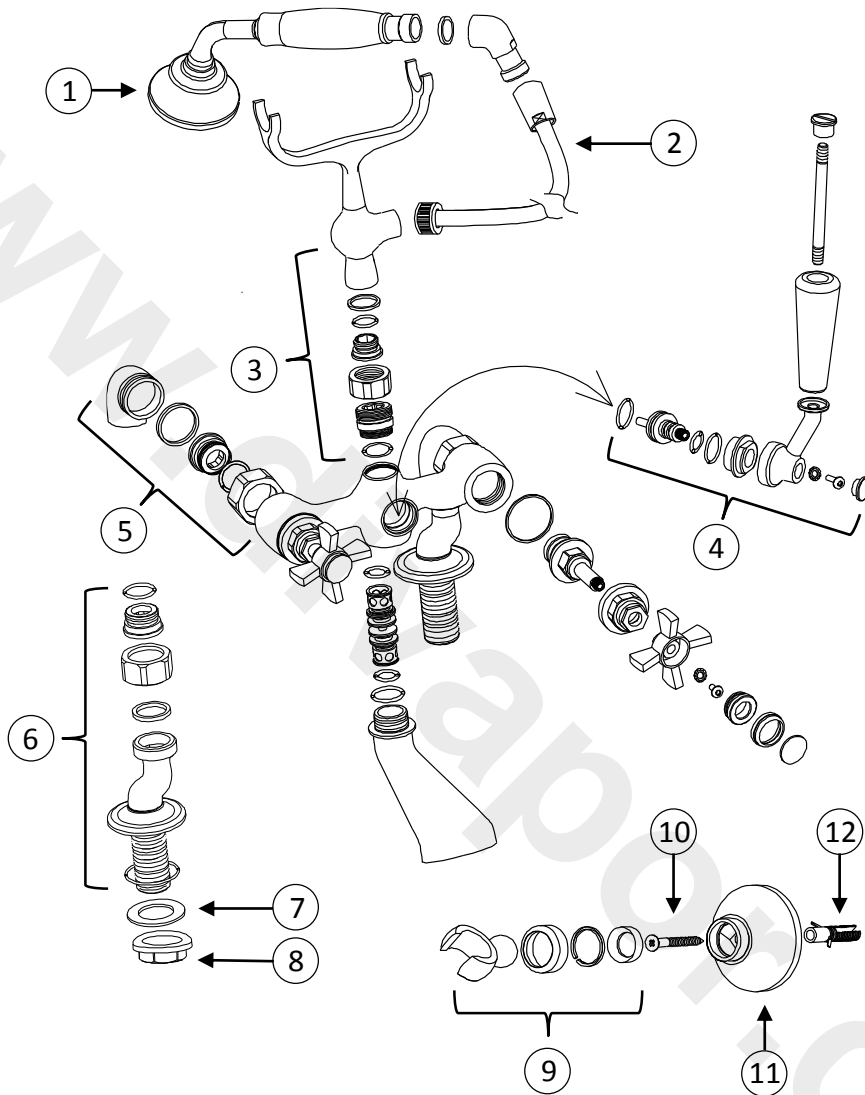

1.	Handset	x1	7.	Washer	x2
2.	Hose	x1	8.	Backnut	x2
3.	Cradle Assembly	x1	9.	Handset Holder	x1
4.	Diverter Assembly	x1	10.	Screw	x1
5.	Elbow Assembly	x2	11.	Shroud	x1
6.	Pillar Assembly	x2	12.	Rawl Plug	x1



Installation – Bath Filler / Bath Shower Mixer Cont.

* Bath shower mixer only

1. Identify all components are present prior to starting installation.
2. Using the washer (7) and backnuts (8) secure the pillars to the bath by tightening the backnuts onto the pre-fitted threaded tails. A suitable spanner may be required to fully tighten the backnuts (8).
3. Connect the elbow assembly (5) to the tap body, ensuring that the washers are correctly placed to avoid any leaks and fit to the already installed pillars (6).
4. * Attach the cradle assembly (3) to the tap body, again ensuring the washers are correctly placed.
5. * Fit the handset (1) to the shower hose (2) and connect the hose to the outlet on the cradle.
6. Connect the hot and cold water supplies.
4. Turn on the water and fully open the mixer, allowing it to run for a few minutes and check all joints and connections for any leaks.
5. * To fit the wall bracket, ensure firstly that the position will allow the handset to comfortably reach it when attached to the 1.5m hose. Mark out and drill the hole to suit the rawl plug (12). Using the screw (10), fit the shroud (11) to the wall and assemble the remaining components as shown in the diagram.

Wall Mount Installation

To wall mount this product, unscrew the elbows from the body and screw the legs directly into the rear inlets of the tap body.

NOTE: This will alter how far out the product will sit proud of the wall. Care must be taken when attaching the product, Please do not place weight on this product when fitting as a wall mounted option.





Maintenance

General Cleaning

Your fitting has a high quality finish and should be treated with care to preserve the visible surfaces. All finishes will wear if not cleaned correctly. The only safe way to clean your product is to wipe with a soft damp cloth. Stains can be removed using washing up liquid. All bathroom cleaning products (powders and liquids) will damage the surface of your fitting, even the non-scratch cleaners.

Note: Never use abrasive detergents or disinfectants or those containing alcohol, hydrochloric acid or phosphoric acid.

See map of Hard Water Regions on page 11 to see the water type in your area

We advise that your fitting is regularly serviced in hard water areas to maintain optimum performance.

Cleaning the Showerhead: TDCC02

Your Heritage showerhead has rub-clean nozzles for easy cleaning. Simply rub your fingers across the rubber spray jets regularly and before you turn the shower on to remove any scale or debris.

The hardness of the water in your area will determine how often you should clean your showerhead. Build up of scale in particularly hard water areas combined with constant use means you may need to clean your showerhead once a week. To ensure continued performance the showerhead needs to be regularly descaled.

Tip: If the showerhead is heavily scaled or has not been maintained for a long period of time a solution of hot water and white vinegar may be needed to clear the scale.

Mix a 50/50 solution and rub the nozzles thoroughly with the solution making sure the solution gets into all of the nozzles. Wash off the solution with clean water.



Maintenance Cont.

Cleaning the Valves

If your fitting begins to leak the following should be carried out;

Isolate both hot and cold water supplies to the tap by either:

- Turning the water supply off at the mains stopcock or
 - Turning off the isolation valves to the tap.
1. Remove the indice, to reveal the screw and washer and proceed to remove these with a suitable screwdriver.
 2. Remove the handle and unscrew the shroud.
 3. Using a suitable spanner remove the valve.
 4. Lift out the valve and clean thoroughly. Be sure to check and clean out the seating within the tap body/assembly.
 5. If necessary replace the valve.
 6. Please visit www.heritagebathrooms.com in order to find spare parts for this product.
 7. Place the valve into the tap body, ensuring the washer is in the required position, and tighten the valve fully using a suitable spanner.
 8. Re-connect the shroud, handle and all other components.
 9. Turn on water supply and check for leaks.
 9. Contact our helpline should if problem persists.

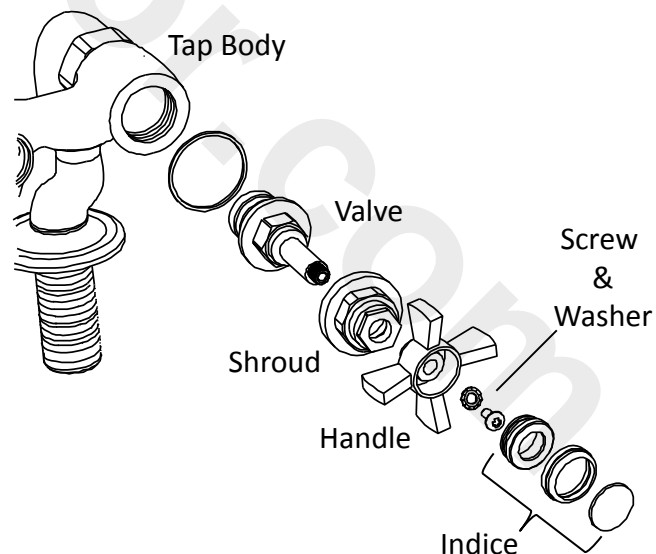
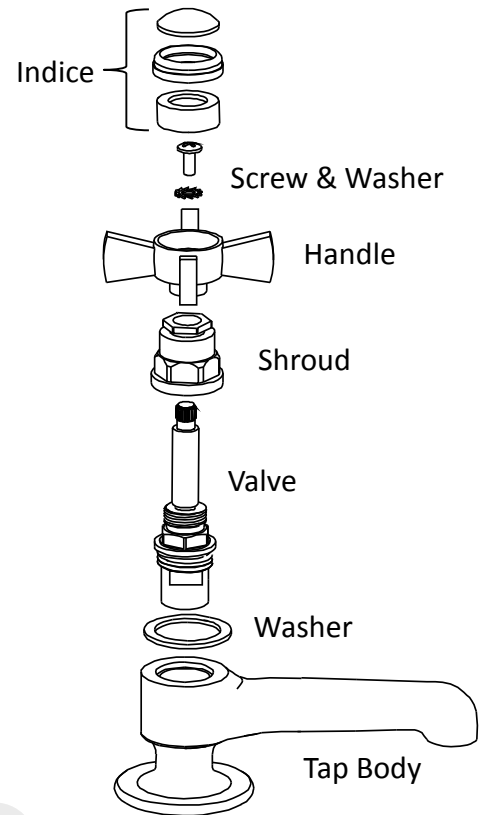



Map of Hard Water Regions



Soft to moderately soft
0 - 100mg/l as calcium carbonate equivalent



Slightly hard to moderately hard
100 - 200mg/l as calcium carbonate equivalent



Hard to very hard
Above 200mg/l as calcium carbonate equivalent

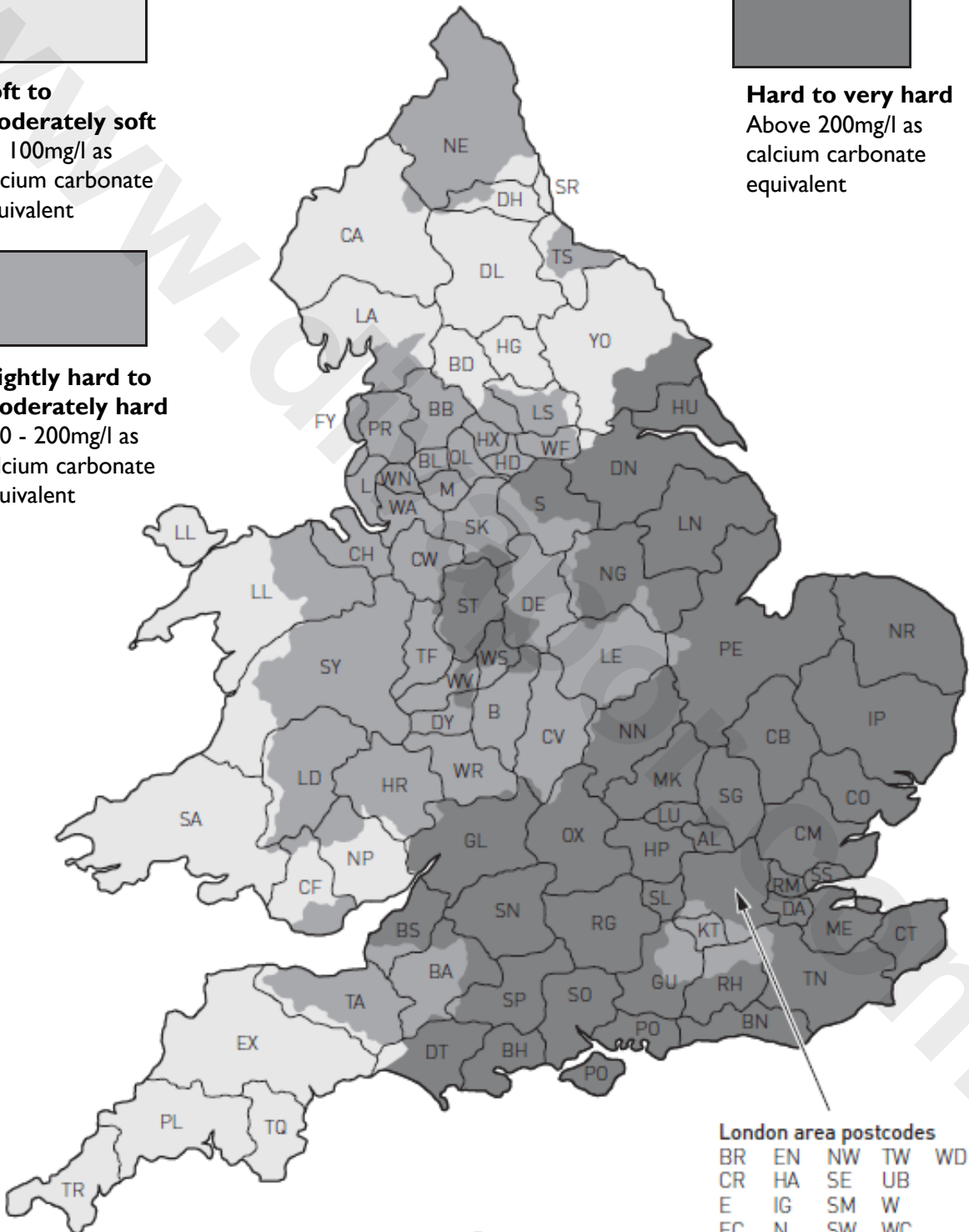

Troubleshooting

Symptom	Cause	Remedy
No flow or poor flow rate.	Partially closed stop or service valve in water supply pipework to the tap.	Open stop or service valve.
	Head of water is below the minimum distance required.	Refer to the Specification section for minimum pressures required.
	Possible airlock / blockage in supply pipework	Remove water supplies from the fitting and flush the system to remove any airlocks / debris.
	Cartridge not opening fully.	Service fitting. Refer to maintenance section on pages 08-09.
Water dripping for a few seconds after the tap has been turned off.	This is caused by 'capillary action' and residual water in the spout being siphoned out. This should only last for a couple of seconds.	
Constant dripping / leaking when the tap is not in use.	Cartridge / Valve not fully shutting off.	Service fitting and replace cartridge. Refer to maintenance section on pages 08-09
Fitting does not turn on.	Water supplies not turned on.	Check that the water supplies to the fitting are turned on.
	Closed stop or service valve.	Open stop or service valve.
Water does not come out of the showerhead when using the bath shower mixer.	Diverter mechanism not fully open.	Turn the diverter mechanism into the appropriate position.
	Insufficient water pressure / header height.	Refer to the specification section for minimum pressures required.





Heritage Bathrooms Guarantee

When you buy a Heritage product, you can be confident that it not only features distinctive design, but that it has also been made to meet our rigorous quality standards.

We offer robust guarantees and an attentive aftercare service to ensure that if you do experience any issues, we can deal with a problem quickly, and effectively.

Please note that guarantees are only valid with proof of purchase.

Our guarantees are as follows:



2 Years on
Mirrors &
WC Seats



5 Years on
Bath Screens,
Furniture,
Shower Valves,
Taps, Wastes
& Accessories



Lifetime Guarantee
on Acrylic &
Cast Iron Baths
And Sanitaryware

Register now for additional peace of mind

Register your product with us now and, if you do have any queries after installation, we'll be able to quickly identify the product and give you the best advice. It also means that you won't have to keep your proof of purchase to validate your guarantee. To register, simply go online at www.heritagebathrooms.com/register

Guarantee Terms and Conditions

This guarantee is in addition to your statutory and other legal rights and is subject to the following conditions:

- The product was purchased within the United Kingdom or Republic of Ireland
- The product is used in domestic applications only
- The guarantee applies solely to the original purchaser with proof of purchase
- The installation must allow ready access to all products for the purpose of inspection, maintenance or replacement
- Repair under this guarantee does not extend the original expiry date. The guarantee on any replacement parts or product ends at the original expiry date

Any part found to be defective during the guarantee period will be replaced without charge, providing that the product has been installed in accordance with the instructions given in this guide and used as the manufacturer intended. If the product is no longer available, Heritage will endeavour to provide the nearest equivalent.



Heritage Bathrooms Guarantee Cont.

The guarantee does not cover:

- Damage or defects caused by
 - General wear and tear (including special non-chrome finishes; components such as filters, seals, 'O' rings and washers)
 - Incorrect installation
 - Repair using non-Heritage parts
 - Accidental or wilful misuse
 - Corrosion and the use of inappropriate cleaning products.
 - System debris including the build-up of limescale (which can be controlled through regular servicing and maintenance)
- Compensation for loss of use of the product or consequential loss of any kind.

In the interests of continuous product improvement, Heritage reserves the right to alter product specifications without notice.

Need help?

In the unlikely event that you encounter a problem with your Heritage product, you must, in the first instance, contact the retailer you purchased it from. They will advise as to whether it is due to a manufacturing fault or an installation fault. If the problem is due to a manufacturing fault, they will contact us to arrange a supply of a replacement product as soon as possible. To speak to a Heritage customer service advisor, please contact our technical helpline on **0844 701 8503**.





Notes

Please use this space to add any notes which you or your installer may have regarding the plumbing, installation, and/or servicing of this product:

www.divapor.com





HERITAGE®
BATHROOMS

Heritage Bathrooms
Birch Coppice Business Park
Dordon
Tamworth
B78 1SG

Website: www.heritagebathrooms.com

Telephone: 0844 701 8503

Email: technical@heritagebathrooms.com

HFI (DAWLISH-BAS/BATH) REV. D 1

