

Guarantee

All VADO products come with a 2 year guarantee as standard. Within this guarantee period VADO will provide replacement parts and any labour **[SEE NOTE 1]** needed to complete the product repair.

This standard guarantee may be extended by registering your product to give up to a 15 year guarantee period. Once registered:

VADO chromed brassware and stainless steel products have a 15 year guarantee

(2 years parts and labour plus 13 years parts only).

VADO Sensori SmartTouch and SmartDial products have a 5 year guarantee (parts and labour).

VADO Identity and i-tech products have a 5 year guarantee (2 year parts and labour plus 3 years parts only).

All other VADO products have a 3 year guarantee (2 years parts and labour plus 1 year parts only) **[SEE NOTE 2]**.

Guarantee Conditions

Our products are guaranteed against manufacturing defects from the date of purchase until the expiry of the relevant guarantee period shown above.

The guarantee is only valid if:

- The product has been installed, used and maintained in accordance with VADO's instructions and subjected to normal use only.
- The defect is not due to use of an unsuitable or inadequate water or power supply.
- The defect is not due to accident, misuse, neglect or incorrect/inappropriate repair (other than by VADO or VADO authorised agents) or damage caused by foreign objects or substances.
- The extended guarantee is only available if you have completed the Guarantee Registration Process.

This can be done via the VADO website or via phone to our aftersales team.

Registration must be completed within 6 months from date of purchase.

Under the extended guarantee period VADO will, at its option, offer to supply any replacement product (or component part) assessed to be defective **[SEE NOTE 3]**.

The guarantee (whether standard or extended) is non-transferable to any subsequent owner.

All claims under the guarantee should be notified in the first instance to our Aftersales department, contact details below, this must be done no later than the last day of the relevant guarantee period.

All claims must be accompanied by proof of purchase (sales receipt or delivery note) from an official VADO dealer.

The guarantee does not extend to any consequential loss or damage.

After repair or replacement, the relevant guarantee period will be calculated from the original date of purchase.

VADO operates a policy of continuous product development and therefore reserves the right to change the product, packaging and documentation specifications without notice. E&OE.

NOTES:

[1] Labour via our engineer network is only available in the UK. Attendance by a VADO engineer or sub-contract engineer will be under our standard terms and conditions.

[2] VADO spare parts and shower hoses are under a parts only guarantee.

[3] VADO reserves the right to charge in advance for a product (or replacement part) pending collection and investigation (at VADO expense) to confirm a defect is due to a manufacturing issue.

If a defect is found the charge will be refunded or cancelled.

This guarantee is in addition to and does not affect your statutory rights as a consumer.

Tel: 01934 745163

Email: aftersales@vado.com

ALTITUDE

3 handle, 3 outlet thermostatic shower valve

User Guide

Keep for future reference

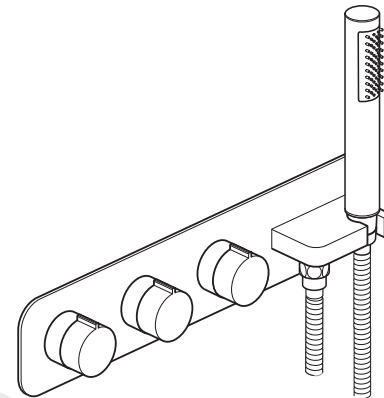

WHERE
INSPIRATION
FLOWS



Welcome

Thank you for choosing VADO

Our products can be found in some of the most prestigious hotel, commercial and residential developments across the world, therefore you can expect exceptional product quality and outstanding customer service.

This product has passed through stringent quality assurance processes coupled with demanding lifecycle mechanical testing to ensure it reaches the exacting standards that allow us to offer our premium 15 year guarantee.

We work to ensure our product designs are harmonious with all sanitaryware, so when you choose VADO, your choice of coordinating items is unlimited.

With VADO, you can really let your inspiration flow.

For any technical or operational queries please contact our experienced aftersales team on 01934 745163.

Cleaning instructions:

The electroplating on this product is finished to the highest standard. Due care needs to be taken to ensure the appearance is retained.

We recommend cleaning all products with a soft damp cloth **ONLY** and advise strongly against the use of all aggressive/corrosive cleaning products i.e. powders and liquids. If these instructions are not followed, this may invalidate your guarantee in the event of a problem occurring.

VADO, Wedmore Road, Cheddar, Somerset, England BS27 3EB
tel 01934 744466 fax 01934 744345
aftersales@vado.com
www.vado.com

Operation - flow control

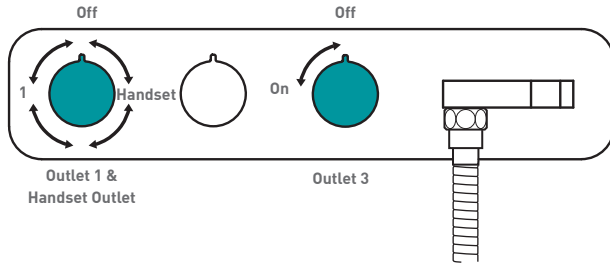
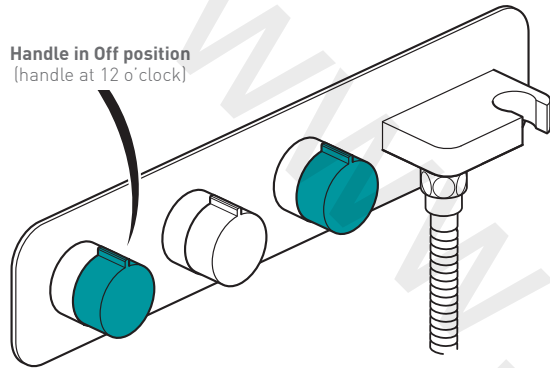

Turning the flow control in the direction of the arrows increases the flow of water to the outlets.

Operation - temperature control

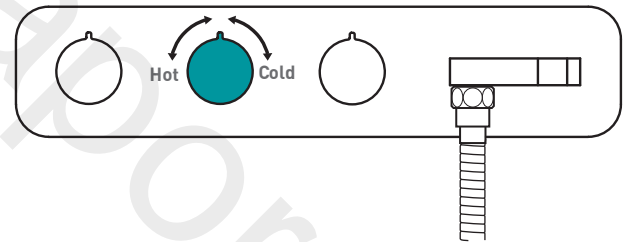
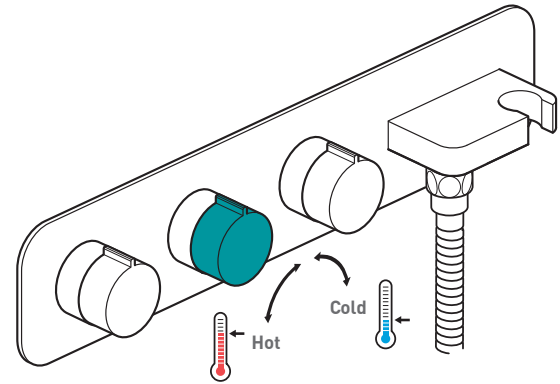

Turning the temperature control handle in the direction of the arrows increases/decreases the temperature

Maintenance

We advise that the below is carried out annually as failure to do so may result in invalidation of warranty.

Shut off the water supply to both hot and cold inlets, before commencing any maintenance work below.

See isolation procedure on page 9.

Thermostatic cartridge

This thermostatic valve is fitted with a single filtering facility. Filters are fitted on the thermostatic cartridge. Depending on the water quality, filters may become dirty, causing reduced flow and inefficient working of the valve. To clean the filters, you must first remove the cartridge from the housing.

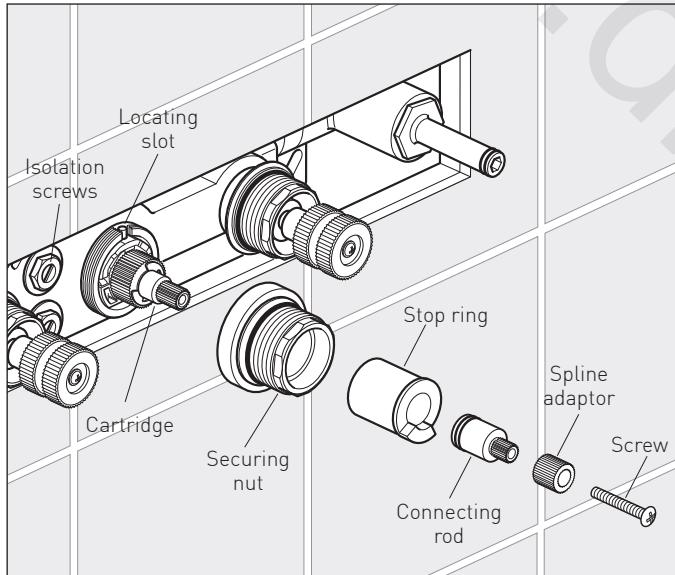

Maintenance

Removing the Cartridge

1. Remove handle assemblies and faceplate allowing access to the isolation points on the valve.
2. Screw down the isolation screws clockwise until you feel resistance (taking care not to over tighten). Ensure the thermostatic valve has been successfully isolated. See page 9 for correct procedure.
3. Remove the screw, spline adaptor, connecting rod and stop ring.
4. Unscrew and remove the securing nut.
5. Carefully pull out the thermostatic cartridge.
6. Clean filters by rinsing them under running water to remove any debris.
7. If there is limescale deposits then it is recommended to immerse the cartridge for a few minutes in 50% white vinegar + 50% hot water, brush the filters gently and then rinse under running water to clean all particles. If this is not effective, a replacement cartridge should be fitted.

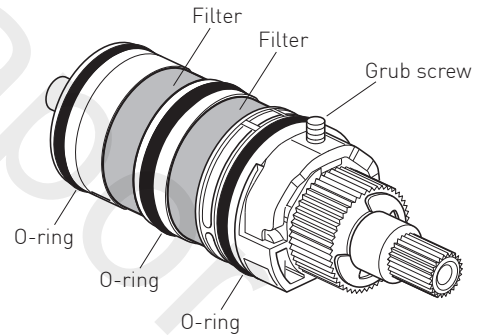

Maintenance

8. Before reassembling the cartridge, clean its housing with a wet cloth and grease the O-rings using a suitable silicone grease, insert the thermostatic cartridge to the valve body ensuring the grub screw is aligned with the slot.
 9. Screw the securing nut on and tighten.
 10. Place the temperature stop ring on the cartridge so the step is located at 8 o'clock.
 11. Place the connecting rod, spline adaptor and screw back onto the cartridge.
 12. Turn the water supply on via the isolating valves.
 13. Check the water temperature to ensure correct commissioning.
- See page 15 of the installation instructions or Vado.com for commissioning.
11. Replace handle assemblies and faceplate.

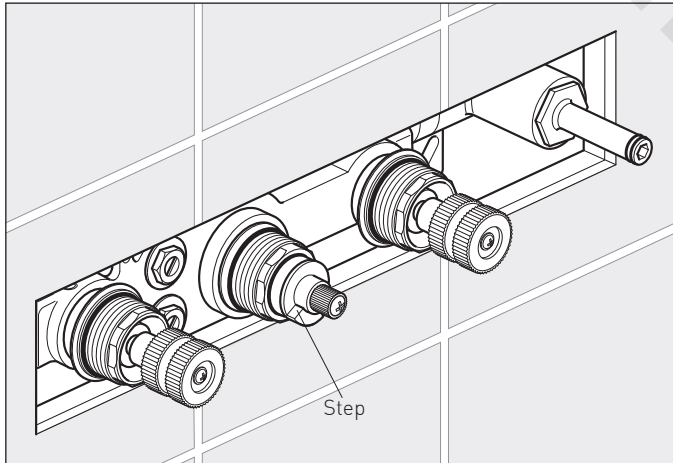

Maintenance

Isolation procedure

IMPORTANT: Please see the below procedure for isolating this thermostatic valve.

1. Remove handles/faceplate and trim parts allowing access to the isolation points on the valve.
2. Screw down the isolation screws clockwise until you feel a resistance (taking care not to over tighten).
3. Turn shower on to check isolation, please ensure that your body/hands are not under the flow of water as there is a potential for delivery of hot water.
4. Remove temperature stop ring (essential).
5. With shower in the on position, replace temperature handle on thermostatic valve (ensure temperature stop ring has been removed).
6. Turn temp handle fully anti clockwise until stop point is reached and can be turned no further, please ensure that your body/hands are not under the flow of water as there is potential for delivery of hot water if isolation has been unsuccessful.
7. Turn temperature handle fully clockwise until resistance is felt.
8. If there is no flow of water coming from the outlet during both points 6 and 7 isolation has been successful, you may now remove and maintain the cartridge.
9. If at any of the above points water continues to flow please isolate at an alternative point within the system for both hot and cold and repeat points 3-9.

Parts list:

Item	Code	Quantity
1	FL-301-RTC	1
2	V-704-34S	1
3	FL-802-33/2MX	1
4	TAB-003A-FIL	1
5	TAB-003A-FIL-HOUSING	1
6	TAB-STOPRING	1
7	TAB-NUT/TEMP-BRA	1
8	TAB-NUT/FLOW-BRA	1
9	TAB-DIV/EXTSPLINE-BR	1
10	TAB-COG-BRA	1
11	TAB-CD/EXTSPLINE-BRA	1
12	TAB-1/FLOW-ALT-C/P	1
13	TAB-1/TEMP-ALT-C/P	1
14	TAB-DIV/COVERNUT-BRA	1
15	TAB-WO/SPIGOT-BRA	1
16	TAB-028/3WOALT-CP	1
17	ZOO-HANDSET-C/P	1
18	SH-013-150-CP-LB	1
19	CEL-CON-3/4MX1/2F-BR	1
20	INSTALLATION GUIDE & USER MANUAL	1

Parts:

