

INSTALLATION INSTRUCTIONS

Stafford Mono basin mixer with pop up waste (including the handles) - STA11

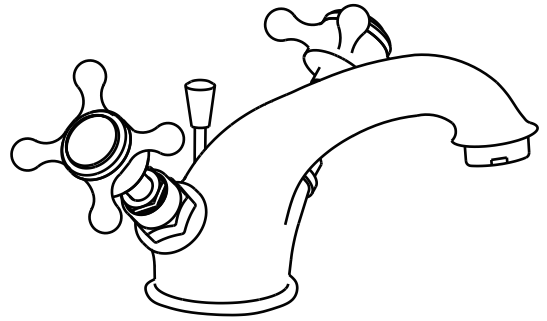

Important

- We recommend that this product is installed by a qualified professional contractor. Such as a plumber who is certified by NVQ (National Vocational Qualification) or SNVQ (Scottish National Vocational Qualification) Level 3.
- Please check this product immediately to ensure that it has not been damaged and is complete. Before installation, please make sure this product is the correct model and you have all the parts required for installation and using.
- All the taps in Burlington Range should be supplied with hot and cold water at balanced pressure. If not, then the mixing function will not work correctly. It is necessary to fit non-return valves on both hot and cold feeds pipe. These are not supplied.
- Please flush the water system to ensure that no metal swarf, solder, and other impurities can enter the taps.
- Turn off water supply before commencing work, this should be done at the isolating valves of inlet feeds if fitted or main stopcock.
- Please read these instructions carefully and keep it for future reference.

Working pressure

The tap is suitable for both high and low pressure installation. To ensure that the tap works well under low water pressure, the cold water storage tank must be at least 2 meters above the installed position. The maximum static pressure is 10 bar, and operating water pressure is 5 bar. Where the operating water pressure above 5 bar, then a pressure reducing valve must be fitted.

Straightener and aerator (alternative option)

The tap comes with a factory-fitted flow straightener for low pressure water systems. If your water is supplied at high pressure you may prefer to change the nozzle to an aerator (not supplied). **To change the nozzle.**

Unscrew the nozzle from the mixer taking care not to loose the washer. Replace the washer, and screw on the chosen nozzle, hand tighten only.

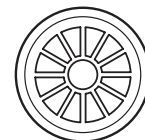

FLOW STRAIGHTENER

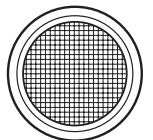

AERATOR
(not supplied)

Dimension

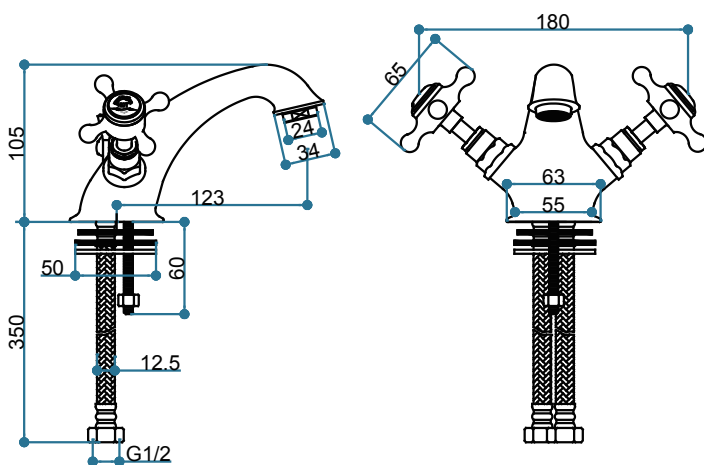

Cleaning

Before use: Unscrew the filter and allow the water to run freely for 5 minutes. Then screw the filter back in place.

Periodically: Unscrew the nozzle and remove. Rinse it with cleaning running water until any loose debris is cleared. Then replace the nozzle and tighten.

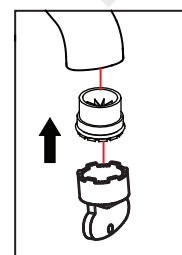
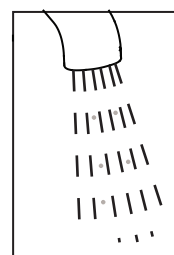
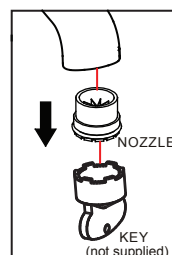

Maintenance

We do NOT recommend you use any household cleaners to clean the product. Because these cleaners change substance or formula too frequently. The product should be always cleaned only with soapy water and rinsed with clean water and dried with a soft cloth.

Installation

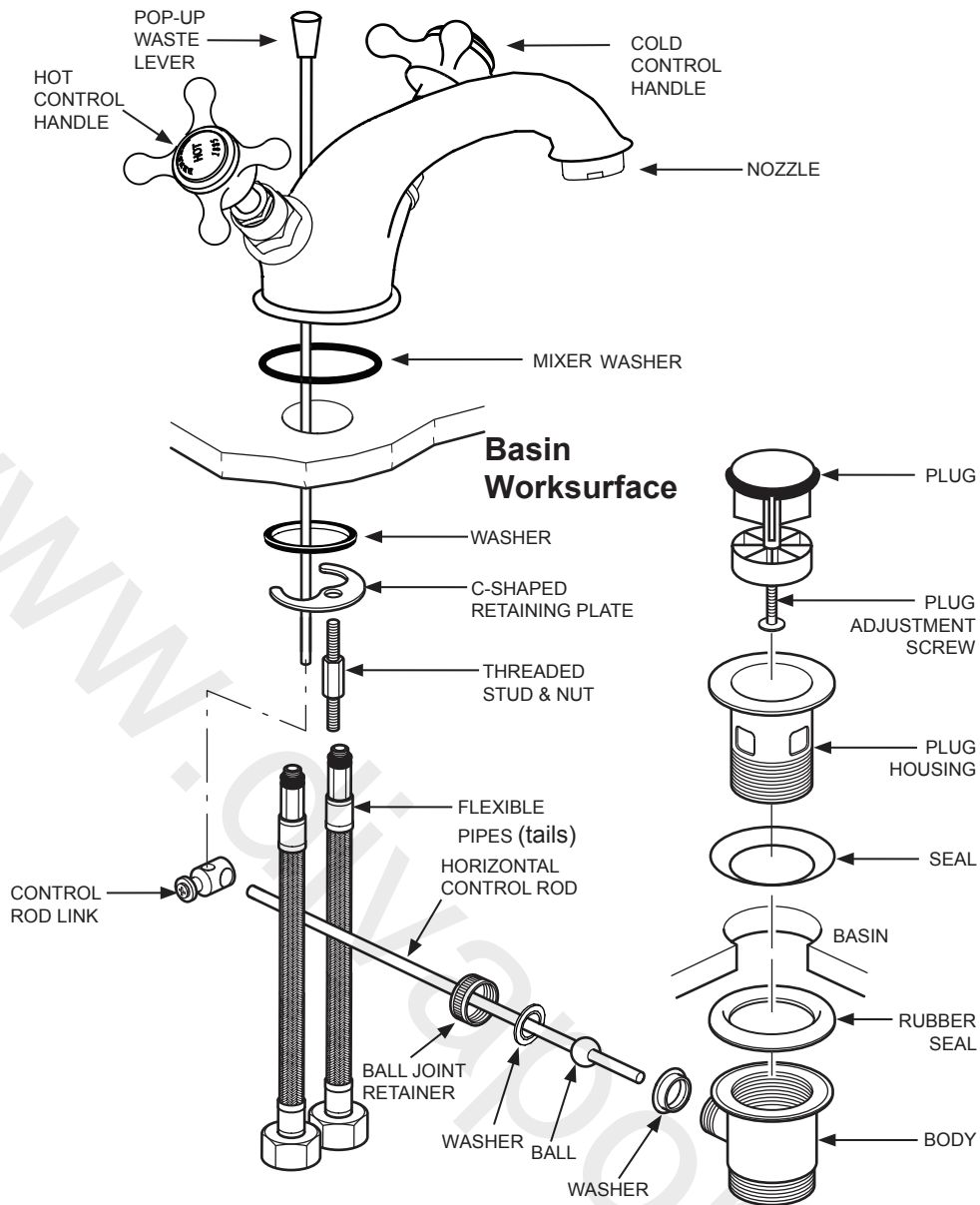

Mixer.

- Fit the mixer washer into the groove underside of mixer body. screw the flexible pipes into the mixer body, and fully hand tighten.
- Place mixer in position to see if any alteration to the existing supply pipe work is necessary, make any necessary alterations to the pipe work.
- Remove the nut from the threaded stud and screw into the base of the mixer. Pass the tails and fixing stud through the hole in the basin from above, and place the mixer in position on the basin.
- Slide the black washer and then the metal retaining plate up the tails and onto the threaded stud, screw on the nut, finger tight to secure the mixer. Check that the mixer body is correctly positioned and tighten fixing nut. The mixer needs to be fixed firmly but do not over tighten as damage may be caused to the basin.
- Hot water should be connected to the left inlet and cold to the right when the mixer is viewed from the front.

Pop-up waste.

- Insert the pop-up waste lever into the slot at the back of the mixer.
- Assemble the pop-up waste to the basin, with the thin washer on top and the thick washer below and hand tighten.
- Prepare the horizontal control rod by sliding on the ball joint retainer, push the washer into the body of the pop-up waste.
- Slide the control rod link onto the pop-up waste lever and then onto the horizontal control rod.
- Insert the short end (with ball) of the horizontal control rod into the body (the horizontal control rod can be slid through the control rod link) and clamp to the body with the ball ball joint retainer. Do not over tighten.
- Test the action of the pop-up waste and fully tighten the rod link. Adjust the ball joint retainer as required.

Attention

Having first checked all new connections, turn on the mains stop cock, close all taps except the new mixer and as the system starts to refill check for leaks. Once you have satisfied yourself that there are no leaks, switch on the water heating.