

*Armitage  
Shanks*

## MARKWIK panel mount dual control sink/ basin mixer

## INSTALLATION INSTRUCTIONS



### MARKWIK S8230AA

- Panel mount mixer for sinks, wash basins or scrub-up troughs
- Markwik quarter-turn brass valves
- Horizontal single flow self-draining spout with minimal restriction brass flow straightener
- Dual control mixer with 150mm lever handles
- Concealed inlets
- Chrome plated all-brass construction mixer

**IMPORTANT**  
BEFORE CONNECTION, FLUSH WATER THROUGH PIPEWORK TO REMOVE ALL DEBRIS ETC. WHICH COULD DAMAGE THE VALVE MECHANISM



**INSTALLER:** After installation please pass this instruction booklet to user

# TABLE OF CONTENTS

1.0 Product introduction.....	3
1.1 Product's long history.....	3
1.2 Markwik advantages.....	4
2.0 Water supply conditions.....	5
3.0 Product dimensions.....	6
4.0 Pre-installation notes.....	7
4.1 General precautions.....	7
4.2 Service valve options.....	7
4.3 Temperature reducing valve.....	7
5.0 Product installation.....	8
6.0 Operating the product.....	9
6.1 Re-setting lever positions.....	9
7.0 Product maintenance.....	10
7.1 Valve adjustment.....	10
7.2 Replacing valve washer.....	11
7.3 Outlet cleaning.....	12
7.4 Spout removal.....	12
8.0 Spare parts list.....	13
9.0 Spare parts diagram.....	15
10.0 Cleaning chrome surfaces.....	16

**The fittings covered by this installation and maintenance instruction should be installed in accordance with the water regulations published in 1999\*, therefore Armitage Shanks would strongly recommend that these fittings are installed by a professional installer**

\*A guide to the Water Supply (Water Fittings) Regulations 1999 and the Water Byelaws 2000, Scotland is published by WRAS (Water Regulations Advisory Scheme)  
Unit 13, Willow Road, Pen-y-Fan Industrial Estate, Crumlin, Gwent,  
NP11 4EG. ISBN 0-9539708-0-9

# 1.0 PRODUCT INTRODUCTION

This Markwik product is a panel mount mixer supplied with dual control 15cm lever handles and horizontal outlet spout. G1/2" threaded male inlet tails are provided for concealed plumbing. When mixer is closed (off position, factory set) the chrome plated levers are parallel to the wall. Lever positions can be adjusted, see section 6.1. Inlet tails will clamp a panel thickness up to 40mm.

The outlet parts can be dismantled to permit cleaning.

This product is fitted with robust Markwik quarter turn brass valves.

Product is suitable for either low or high pressure systems. With reference to **IRN R010**, hot & cold water supply pressures should be reasonably balanced from a common source. Note that single flow mixers require appropriate back flow prevention device to be fitted into the water supply lines immediately upstream of the inlets. Ideally the supplies should also be fitted with inline isolating valves to facilitate future maintenance of the product. The product would be further protected from water borne debris by fitting strainers (filter/mesh). See section 4.2.

Consideration should be given to safe hot water delivery. Conduct a risk assessment of the application/setting & seek approval from the local Water Safety Group (WSG). If necessary, use an appropriate temperature reduction device. See section 4.3.

## 1.1 PRODUCT'S LONG HISTORY

The Markwik range of dual control fittings was originally designed back in the late 1960's. This is one of our most enduring and robust products.

Many of the original design features are still relevant today:

- Mixer is constructed from brass materials.
- Once the valves are closed, the bridge piece & spout will self-drain, evacuating water volume back to the valve seats.
- The fitting has very low static water volume.
- The majority of the brass valves are housed within the handles & not in the water way.
- The brass flow straightener provides minimal restriction to the water flowing from the outlet.
- Minimalist outside surface facilitates easy cleaning.

The excellent original design and performance of this fitting has resulted in it being widely specified in healthcare applications where a manual mixer is required following the necessary risk assessment process shown in HTM 04 – 01 guidelines.

## 1.2 MARKWIK ADVANTAGES

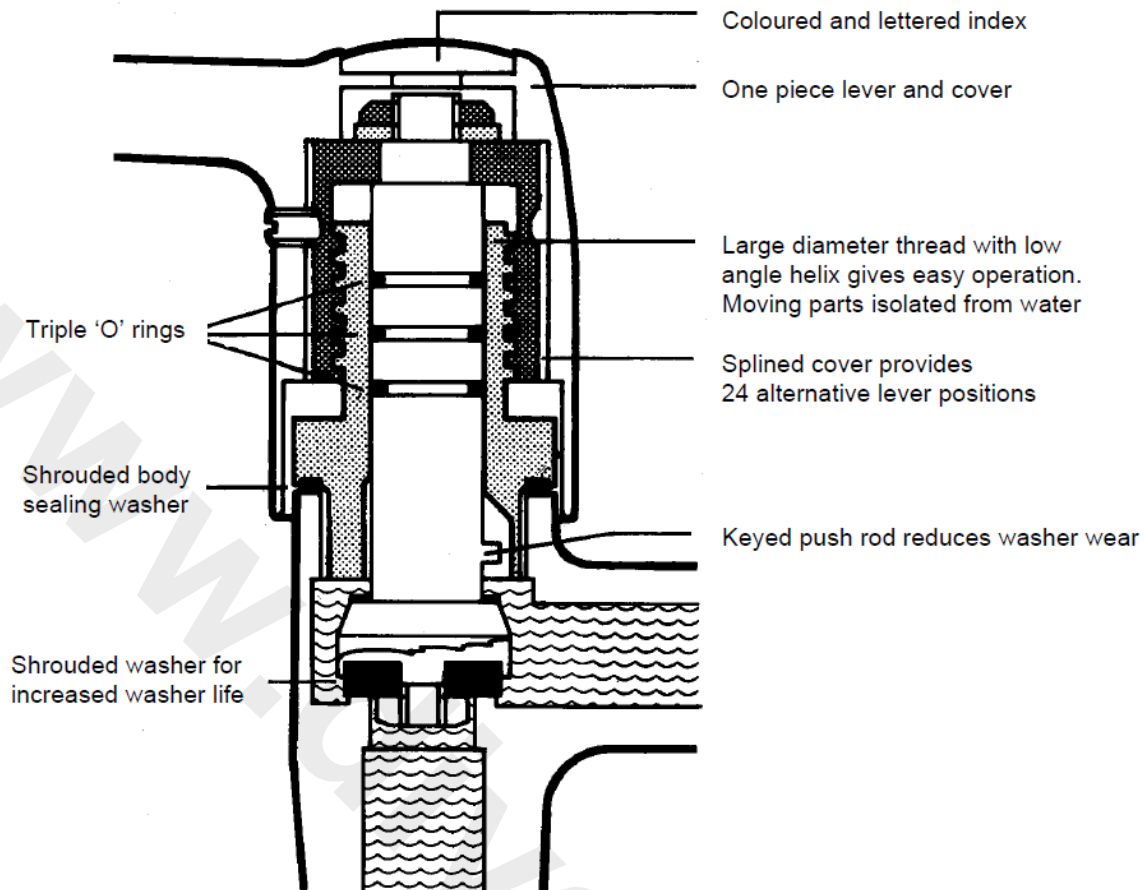

Markwik lever operated taps & mixers have been specially designed to give advantages over conventional lever operated fittings. Particular attention has been paid to hygiene, ease of operation, reliability and minimal maintenance.

### Hygiene

Markwik fittings have a one piece lever and cover protecting the mechanism from contamination. The simple external lines inhibit the accumulation of harmful bacteria.

### Ease of operation

The increased thread diameter and the consequent reduction in the helix angle minimises operating resistance for easy action.

### Durability

A keyed push rod instead of a screwed spindle ensures that the valve washer always seats in the same place and the shroud prevents spreading, reducing washer wear.







### Less maintenance

As the operating thread and its components do not come into contact with the water, lubrication lasts longer. When necessary, maintenance can be effected quickly and easily.

### Installation

Hot lever is to the left & cold to the right when viewed from the front. Valves are in the closed position when the levers are parallel to the wall. This arrangement may be varied to suit site requirements as the heads are interchangeable and offer 24 positional adjustments of 15°. See section 6.1.

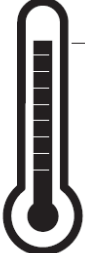
## 2.0 WATER SUPPLY CONDITIONS

 P	bar	 MAX. 10 0,5	Recommended  5 0,5 
 T	C	 MAX. 80	 41 Recommended 

### Supply temperatures:

Avoid supplying scalding water to the HOT inlet. Hot water temperature supply should be controlled to 41°C maximum for safe hand washing.

CAUTION: The mixer can deliver the maximum hot water supply temperature.

In order to maintain water quality, the hot supply should be stored & distributed at a temperature greater than 55°C.

With reference risk assessment mentioned in section 1.0, if necessary fit an appropriate temperature reduction device (i.e. tee pattern thermostat) upstream of the hot water inlet. This is to ensure delivery of safe hot water temperatures from the mixer. See section 4.3.

### Supply pressures:

This product should be plumbed to reasonably balanced-pressure water supplies for best mixing performance. Refer to **IRN R010** note in section 1.0.



For more information about our products visit our websites:

[www.armitage-shanks.co.uk](http://www.armitage-shanks.co.uk)  
[www.idealspec.co.uk](http://www.idealspec.co.uk)  
[www.fastpart-spares.co.uk](http://www.fastpart-spares.co.uk)

Armitage  
Shanks



# 3.0 PRODUCT DIMENSIONS

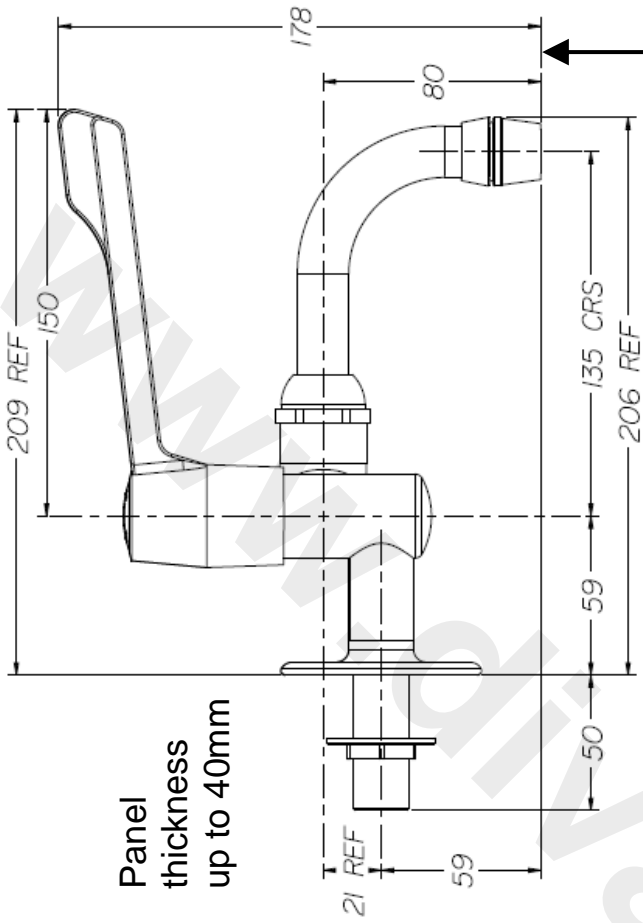

In healthcare applications the height of the fixation holes above the “waste appliance” should be selected to create the recommended “activity space” as defined in HBN 00-10 Part C, typically 150mm – 200mm for a basin and 250mm – 300mm for a surgeon’s scrub up trough.

Waste appliance

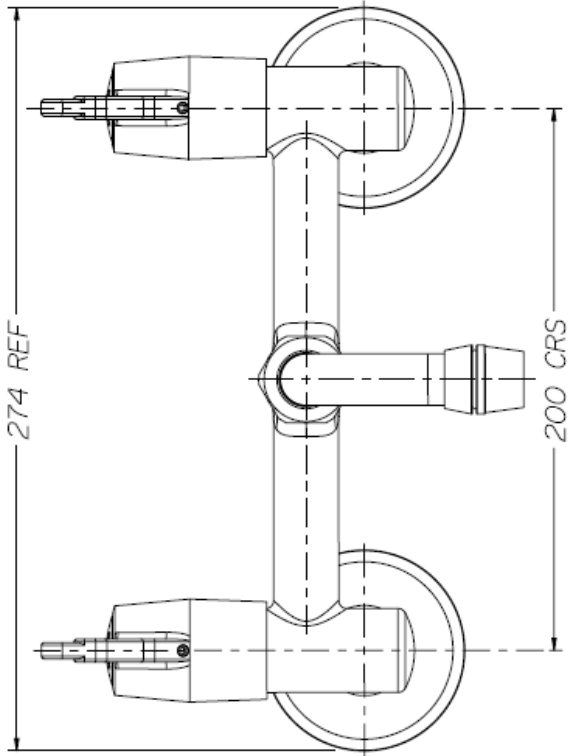

6

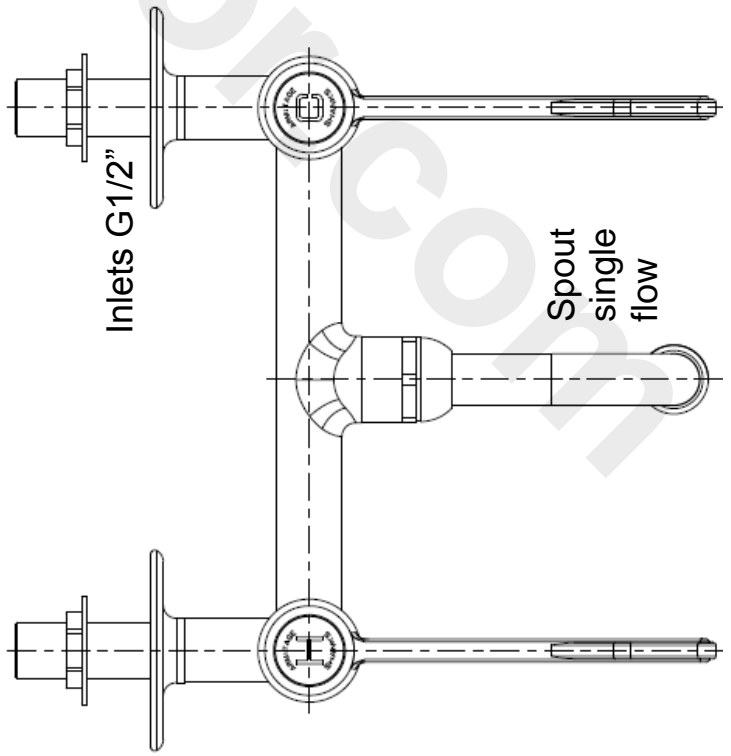

## 4.0 PRE-INSTALLATION NOTES

### 4.1 General precautions



**IMPORTANT NOTE:**

Before connecting the product, it is strongly recommended to flush the supply pipe-work to remove any plumbing residues or debris remaining after installation

**DO NOT** apply heat near this product. Heat generated by soldering could damage plastic parts and seals.



### 4.2 Inline service valve options



**S9005AA.** Basic valve with “isolating only” feature. 15mm compression fittings at both ends. Plated finish.

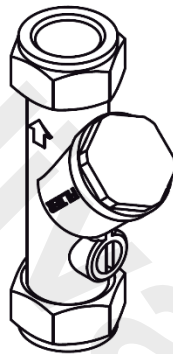

**E960086NU.** Brass valve with isolating & filter only features. 15mm compression fittings at both ends. Supplied in pairs.

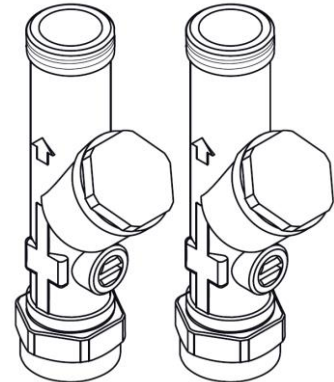

**E960613NU.** Brass valves with “isolating, strainer (filter/mesh), check valve & flow regulator” (4 LPM, removable) features. 15mm compression fittings at one end & G1/2” male thread at the other. Supplied in pairs.

### 4.3 Temperature reducing valve



**A5900AA.** Thermostatic mixing valve (TMV) with 15mm compression fittings. Plated finish. A TMV should be fitted as close as possible to the mixer’s inlets, but always within two metres. Volume of blended water should be kept to a minimum.

To establish if a TMV is necessary, a risk assessment should be conducted & approved by the local WSG before fitting. Alternative products such as Markwik 21+ A6682AA with point of use thermostat may be better.

**NOTE: Valves shown above are not supplied with this Markwik product. Contact Fastpart or our customer care team for more details.**

## 5.0 PRODUCT INSTALLATION

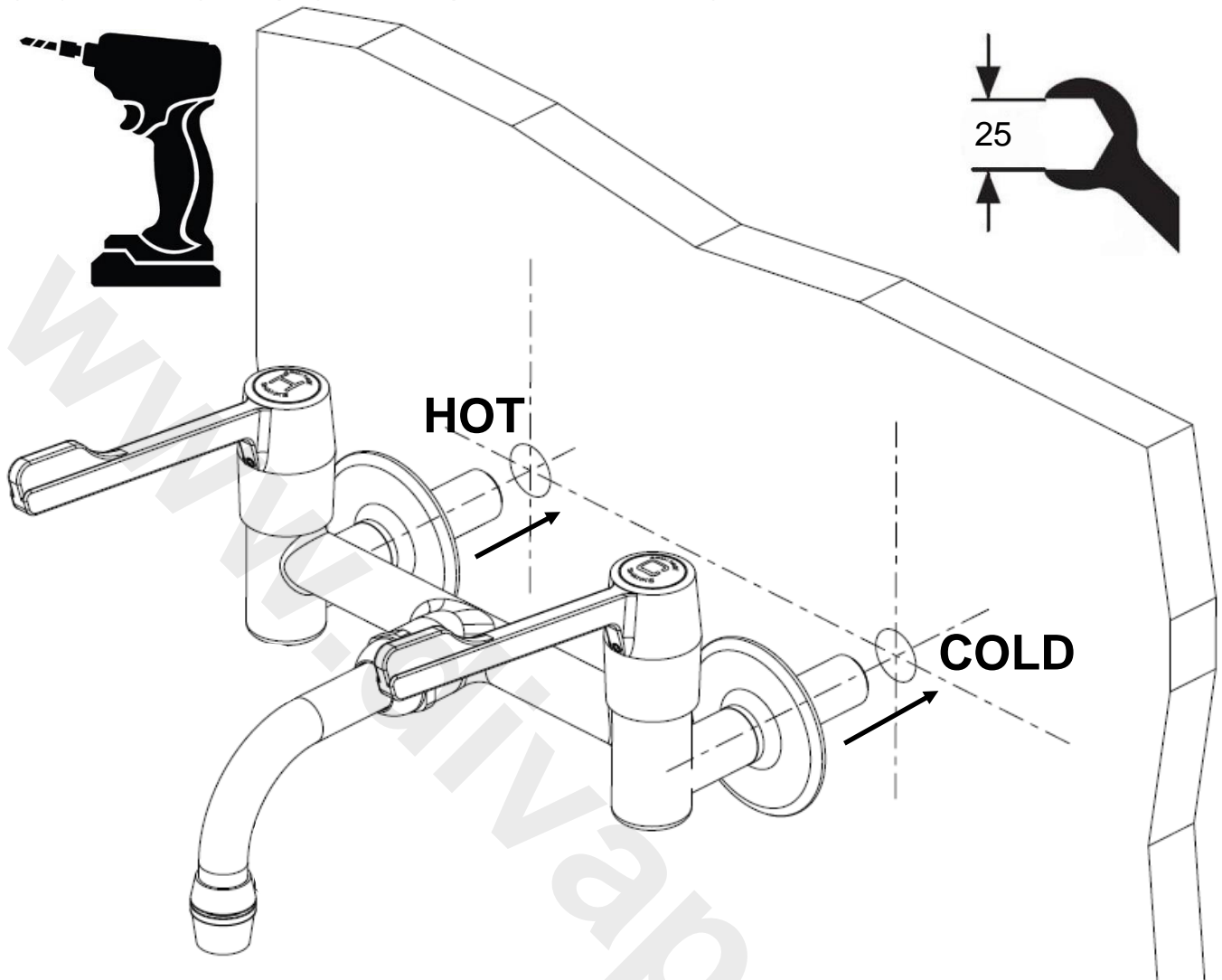

This mixer is designed for panel mounting on a duct wall of maximum thickness of 40mm. For thicker panels the rear of the panel will require a counter bore of Ø50mm or greater.

Cut two Ø22mm holes horizontally aligned at 200mm centres.

NOTE: For height positioning of the mixer over a “waste appliance” such as a wash basin, observe recommended “activity space” shown in the drawing in section 3.0. For other applications, where activity space is not applicable, observe **IRN R040**, which states minimum air gap must be 25mm.

Insert the fitting into the panel as shown above with the wall plates to the front of the panel. Fit the back-nuts to the rear of the panel. Tighten to a torque of 25Nm. Use adjustable spanner for back-nuts (25mm A/F).

Connect the plumbing supplies using G1/2” swivel couplers or similar. Ø15mm pipes can be connected using suitable compression fittings. Check that all joints are securely tightened, check for leaks.

**NOTE:** Connect the hot water supply to left inlet leg & the cold water supply to right inlet leg (as viewed from front).

## 6.0 OPERATING THE PRODUCT

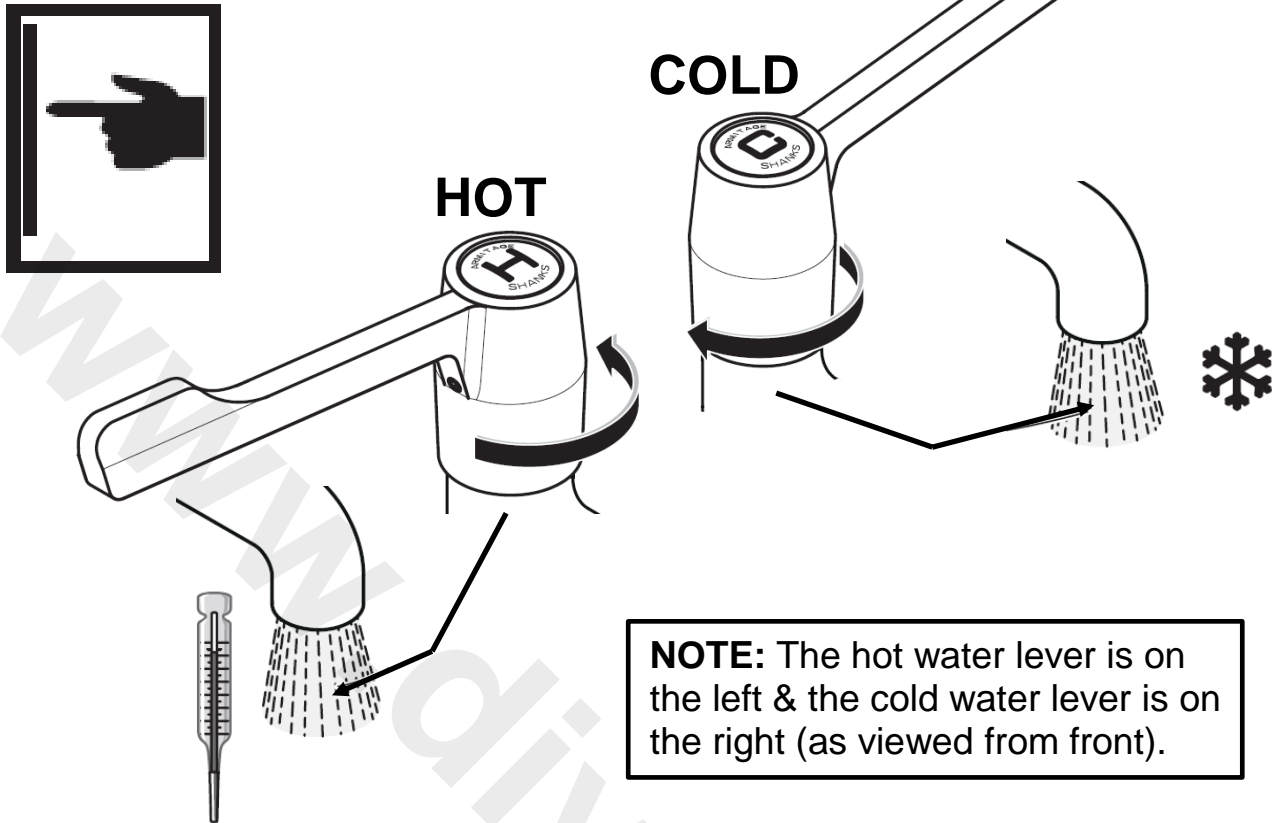

This Markwik mixer is fitted with dual control 15cm lever handles. The flow of hot & cold water can be controlled independently by each lever or both levers can be operated together to obtain a comfortable mixed temperature flow.

At the factory, the mixer closed position (flow off) is set where the levers would be “parallel to the wall”. This product is fitted with robust Markwik quarter turn brass valves. Each lever will rotate 90° in the direction shown. Full flow is obtained with levers normal to the wall.

**NOTE:** Both hot & cold water should be run regularly to prevent water stagnation in the water supply pipes.



## 6.1 RE-SETTING LEVER POSITIONS

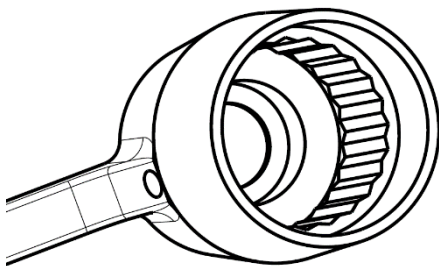

The lever handles are splined internally, allowing the installer (or end user) to adjust the on/off position of the levers. Undo the lever handle grub screws, lift the lever handles off the brass valves, rotate lever to desired position, push lever handle back onto valve & refit grub screw. Up to 24 positions are available at 15° intervals.

If necessary, the valves can be swapped from side to side, permitting valves to operate in the opposite direction from that shown in section 6.0.

## 7.0 PRODUCT MAINTENANCE



### 7.1 VALVE ADJUSTMENT

Occasionally, the valves may need slight adjustment, if they begin to self-open. There two reasons why a valve will self-open:

1. Tension on 13mm locking nut has reduced.
2. Excessive grease applied on the internal thread.

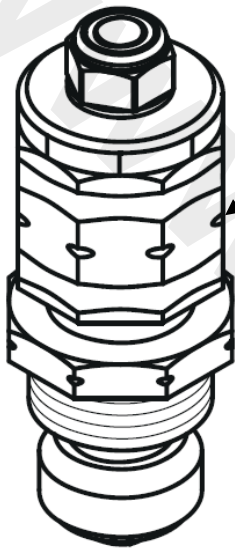

NOTE: Left valve (hot) has notched identifier feature in the octagon.

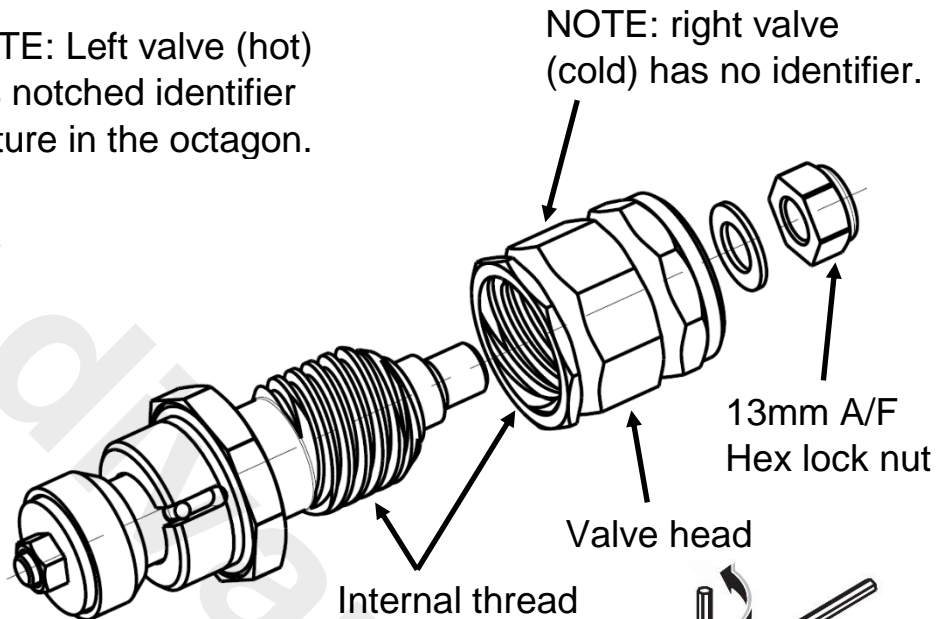

NOTE: right valve (cold) has no identifier.

13mm A/F Hex lock nut

Valve head

Internal thread

Removal of the valves from the mixer is not necessary.

1. Isolate both water supplies.
2. Undo the grub screw & remove the lever handles.
3. Hold the valve head steady with a 27mm spanner. Remove the 13mm (A/F Hex) locking nut & washer.
4. Unscrew the valve head to reveal the internal thread.
5. Lightly remove any excess grease (only a small amount is required to operate the valve).
6. Re-assemble the valve head by screwing it back on - all the way.
7. Locking nut should be tightened so movement is still possible.
8. Turn on the water supplies & test the valve, with the lever refitted.
9. Re-set the lever on/off position if necessary, see section 6.1.

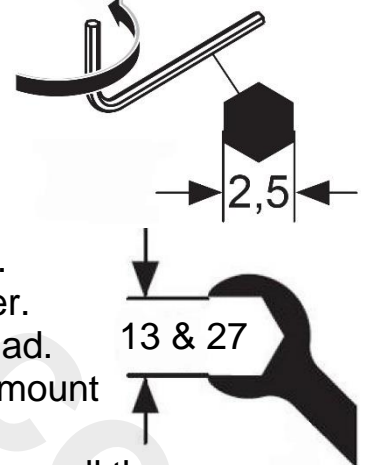

NOTE:

- If the locking nut is too loose, the valve will self-open.
- If the locking nut is too tight, the valve becomes difficult to operate.

Any excessive force applied to the lever will be transmitted to the internal thread. Overtime, this could cause damage to the internal thread. A small adjustment may be required - as little as 1/8th of a turn.

## 7.2 REPLACING VALVE WASHER

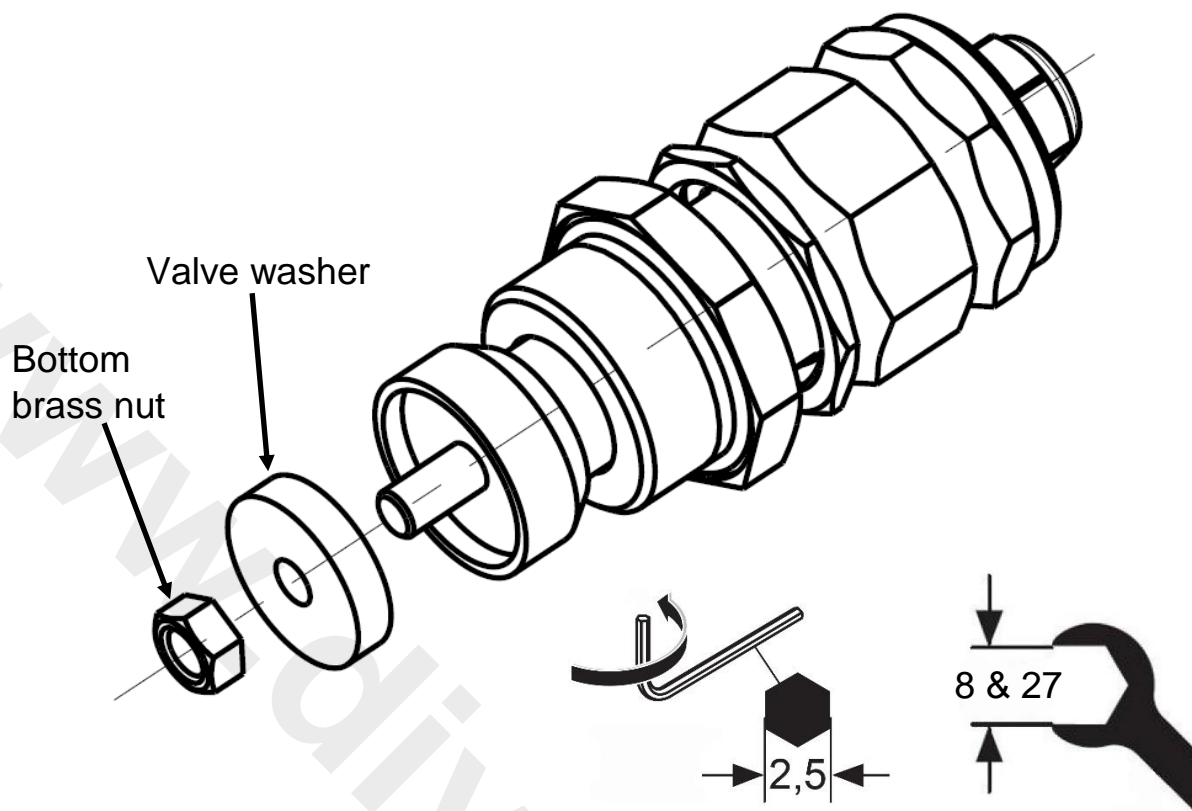

If the mixer begins to drip water, one or both valve washers maybe damaged or have worn out. Check and /or replace the washers fitted to both valves.

Removal of the valves from the mixer is necessary.

1. Isolate both water supplies. Rotate the lever handles to the fully open position, allowing pressure & water to be released from the spout. This also confirms water is switched off.
2. Undo the grub screws & remove the lever handles.
3. Undo valves with a 27mm spanner. Remove the valves from the mixer. Expect a small amount of water to escape from the mixer body.
4. Hold the valve head steady with a 27mm spanner. Remove the 8mm (A/F Hex) brass nut & valve washer.
5. Replace the valve washers with a new ones & re-screw the brass nuts tight.
6. Re-assemble the valves back into the correct sides of the mixer body. Observe the hot valve identifier, see section 7.1.
7. Refit the lever handles & rotate to off position.
8. Turn on the water supplies & check for leaks.
9. Re-set the lever on/off position if necessary, see section 6.1.

**NOTE:** This mixer is fitted with a horizontal self-draining spout. When the valves are closed, a small volume of water will be expelled from the spout until the spout & bridge parts of the mixer are drained down.

## 7.3 OUTLET CLEANING

On a regular basis the outlet should be inspected and cleaned. Note: Lime scale deposits should be removed prior to using any disinfection treatments.

To access the minimal restriction flow straightener, simply unscrew and remove the outlet housing (should be hand tight). The brass min-res flow straightener can be pushed out of the outlet housing.

If this flow straightener becomes loose, the springy brass material can be stretched slightly to improve the fit.

In areas where lime scale build-up is prevalent this should be avoided by regular cleaning. If it should build up, it will have to be removed. An inhibited proprietary scale solvent can be used such a kettle descaling solvent but it is important to follow the manufacturer's guidelines.

Avoid using solvents containing ammonia.

After descaling it is important to rinse the parts thoroughly in clean water. Clean carefully and do not use abrasive materials or scrapers.

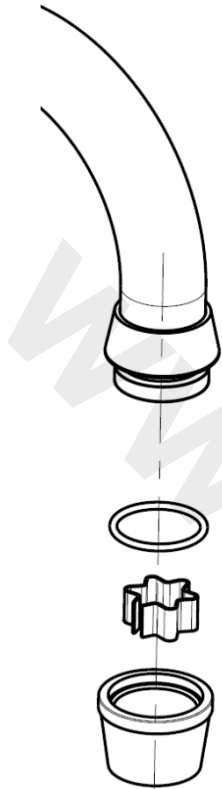

## 7.4 SPOUT REMOVAL

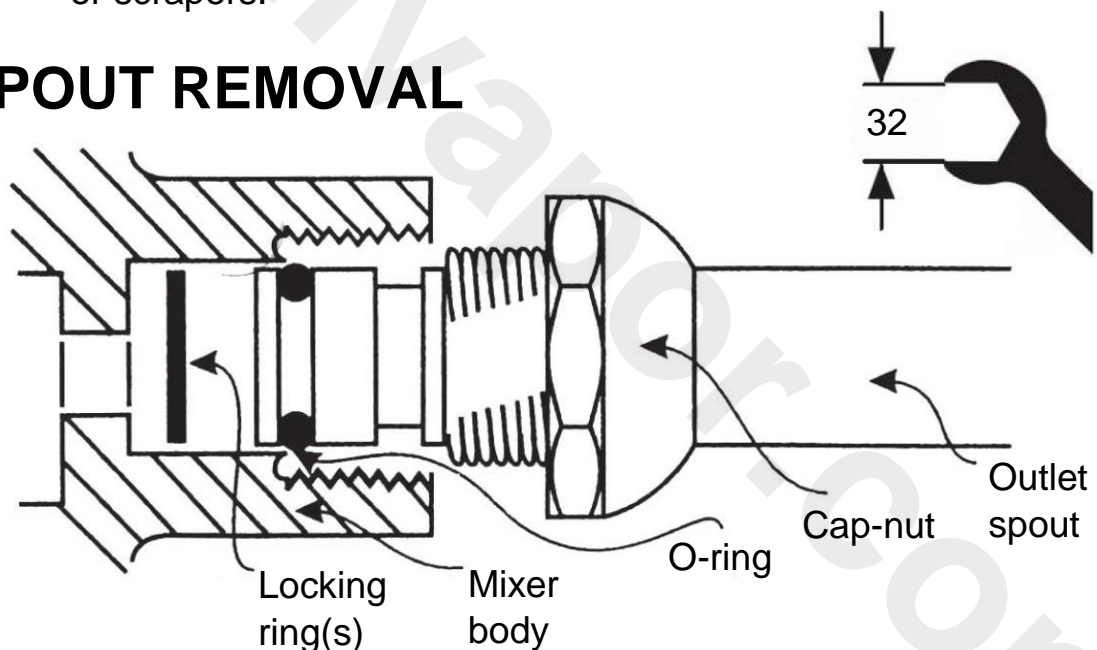

This mixer is fitted with a quick easily removable spout to assist with cleaning, disinfection by immersion or sterilisation by autoclaving. Procedure assumes availability of a replacement spout. For both practical functional reasons along with environmental contamination reasons, the mixer should not be left without a spout fitted in place.

Use a 32mm A/F spanner (or adjustable) to undo the cap-nut. Once released, the spout can be gently pulled away from the mixer body, taking care not to damage the O-ring seal.

The O-rings & locking ring(s) should be kept in a safe place during cleaning. Ensure these are refitted back in their correct positions.

**NOTE:** Take care to avoid damaging chromed surfaces.

## 8.0 SPARE PARTS LIST



Use the spares parts list together with the exploded diagram shown on the next pages to identify the required spare part(s).

**Spares item 9**, O-ring & seating washer repair kit for a pair of valves **S9624NU**.

Parts shown here are supplied in this repair kit.

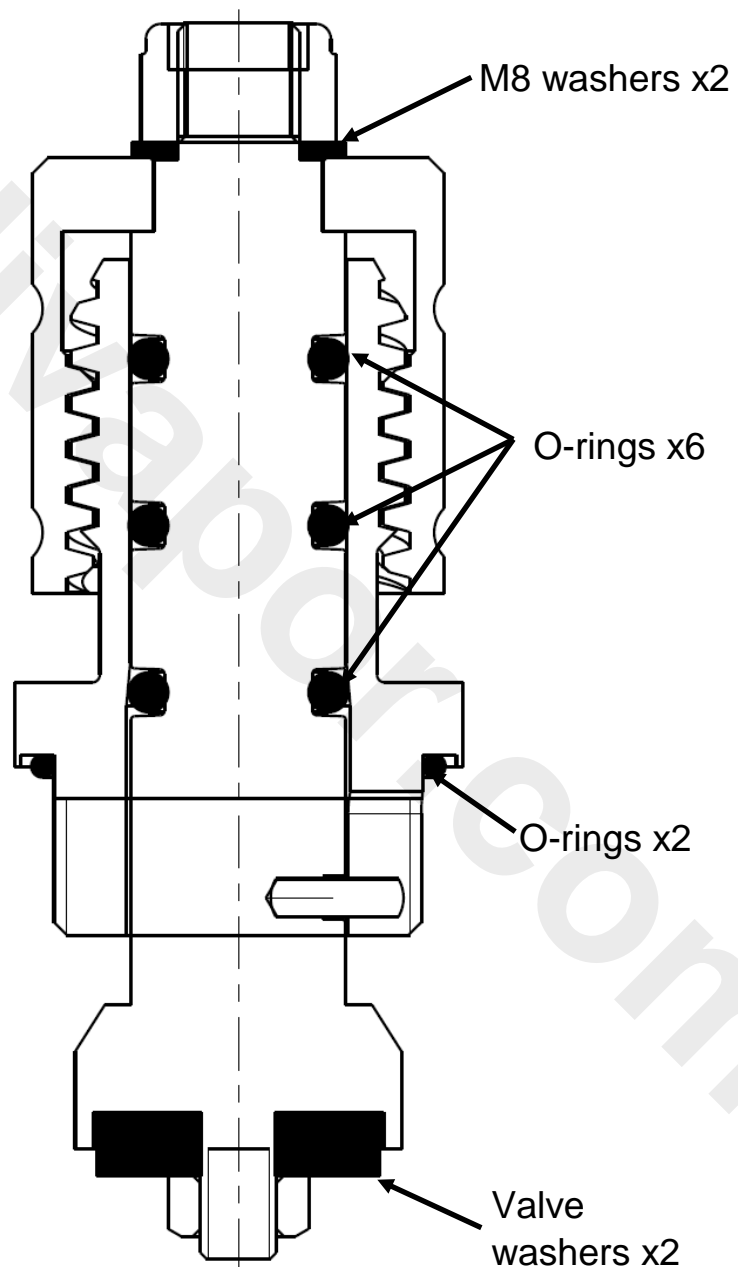

Section through valve

## 8.0 SPARE PARTS LIST cont'



Ref	Description	Qty	Spare part No
1	Markwik indice pack, H & C	Pair	S9599NU
2	M5 x 6mm long. Handle grub screw	Single	SV37967
3	Markwik 150mm levers with indices & grub screws	Pack	S961228AA
4	Markwik 1/2" quarter turn brass valves pack, H & C	Pair	S9610NU
5	G1/2" flanged brass back-nuts	Pair	S960970NU
6	Chromed outlet housing & brass min res flow strnr	Single	S961057AA
7	Chromed horizontal spout & brass min res flow strnr	Single	B961617NU
8	Brass washer & O-ring pack - for spout	Pack	S961171NU
9	O-ring & seating washer repair kit for a pair of valves	Pack	S9624NU
10	1/2" Valve washer - bulk pack	10	B961618NU
11	Brass min restriction flow straightener - insert only	Single	S961044NU



*Armitage  
Shanks*

For more information on spare parts why not visit our spare website:  
[www.fastpart-spare.co.uk](http://www.fastpart-spare.co.uk)  
 or contact customer care



# 9.0 SPARE PARTS DIAGRAM

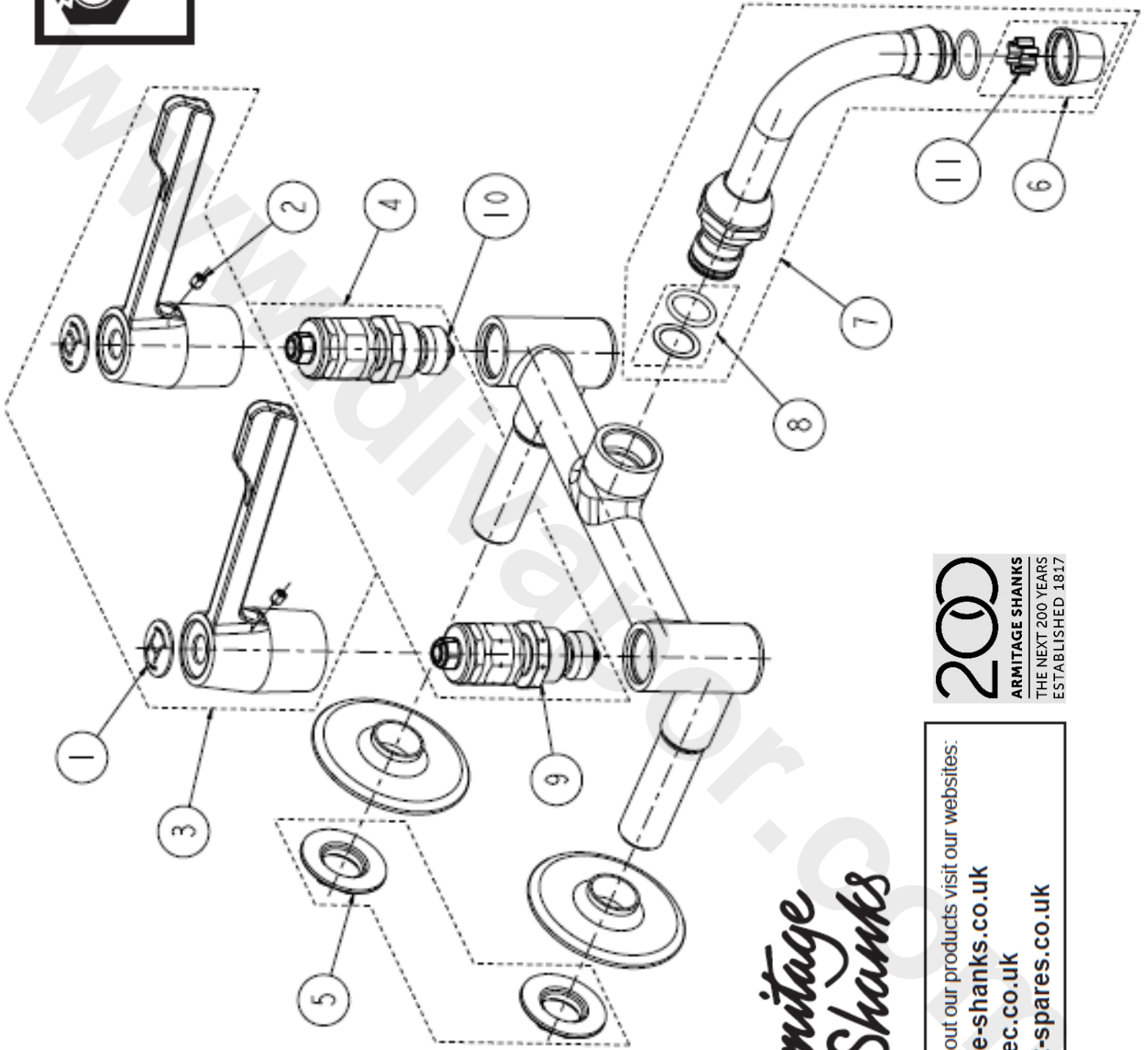

**fast part**  
*Armitage Shanks*

**200**  
 ARMITAGE SHANKS  
 THE NEXT 200 YEARS  
 ESTABLISHED 1817

For more information about our products visit our websites:  
[www.armitage-shanks.co.uk](http://www.armitage-shanks.co.uk)  
[www.idealspec.co.uk](http://www.idealspec.co.uk)  
[www.fastpart-spares.co.uk](http://www.fastpart-spares.co.uk)

## 10.0 CLEANING CHROME SURFACES

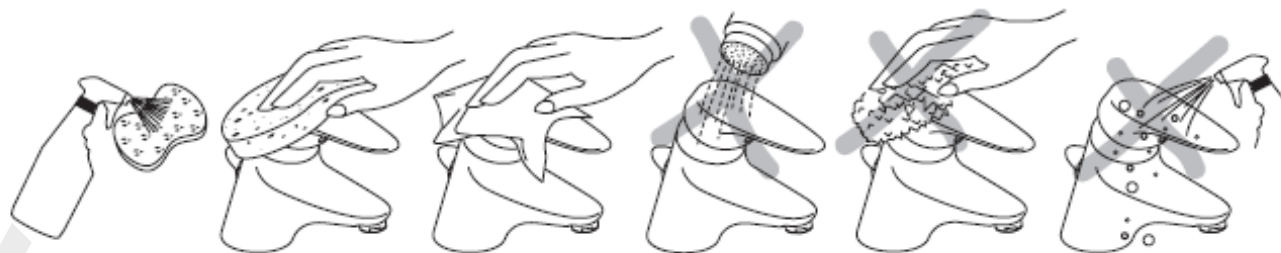

When cleaning chromed products use only a mild detergent, rinse & wipe dry with a soft cloth. Ideally clean after each use to maintain appearance.

Never use abrasive, scouring powders or scrapers. Never use cleaning agents containing alcohol, ammonia, hydrochloric acid, sulphuric acid, nitric acid, phosphoric acid or organic solvents. Use of incorrect cleaning products / methods may result in chrome damage which is not covered by the manufacturer's guarantee.

**fast  
part**

For more information about our products visit our websites:

[www.armitage-shanks.co.uk](http://www.armitage-shanks.co.uk)

[www.idealspec.co.uk](http://www.idealspec.co.uk)

[www.fastpart-spares.co.uk](http://www.fastpart-spares.co.uk)

**200**

**ARMITAGE SHANKS**  
THE NEXT 200 YEARS  
ESTABLISHED 1817



**AFTER SALES NON RESIDENTIAL HELPLINE**

**0870 122 8822**

**AFTER SALES NON RESIDENTIAL FAX**

**0870 122 8282**

**E-MAIL**

**[aftersalesnonresidential@idealstandard.com](mailto:aftersalesnonresidential@idealstandard.com)**

Armitage Shanks pursues a policy of continuing improvement in design and performance of its products.

This right is therefore reserved to vary specification without notice.

Armitage Shanks is a division of  
Ideal Standard (UK) Ltd

Ideal Standard International NV  
Corporate Village - Gent Building  
Da Vincilaan 2  
1835 Zaventem  
Belgium

[www.idealstandardinternational.com](http://www.idealstandardinternational.com)



*Armitage  
Shanks*

B665976 06/19