

# inta

---

## PURO

### Puro Mini Dual Control Shower Mixer

### PU90010CP

### Installation and Maintenance Instructions

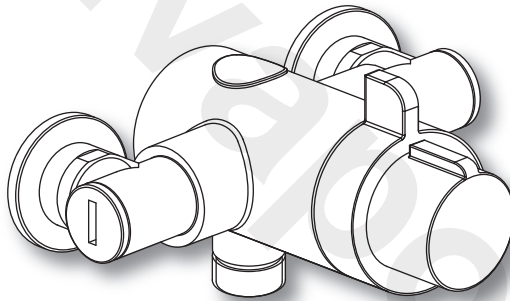

# inta

**Intatec Ltd**

Airfield Industrial Estate

Hixon

Staffordshire

ST18 0PF

In this procedure document we have endeavoured to make the information as accurate as possible.

We cannot accept any responsibility should it be found that in any respect the information is inaccurate or incomplete or becomes so as a result of further developments or otherwise.

Tel: **01889 272 180**

Fax: **01889 272 181**

email: **sales@intatec.co.uk**

web: **www.intatec.co.uk**

## Introduction

This installation guide has been produced for the Puro concealed and exposed thermostatic dual control shower mixing valves. These instructions cover the installation, operation and maintenance. Please read the enclosed instructions before commencing the installation of this product, please note;

**We recommend that the installation of any Inta product is carried out by an approved installer.**

The installation must be carried out strictly in accordance with the Water Supply (Water Fitting) Regulations 1999 and any local authority regulations.

If in doubt we recommend that you contact WRAS - Water Regulations Advisory Scheme on Tel: 0333 207 9030, your local water authority - details available on the WRAS website or the Chartered Institute of Plumbing and Heating Engineers on Tel: 01708 472 791.

All products **MUST** be re-commissioned to suit site conditions to ensure optimum performance levels of the product are obtained.

## Safety

This thermostatic shower must be installed and commissioned correctly to ensure that water is supplied at a safe temperature to suit the users.

43°C is the maximum mixed water temperature from a shower mixer. The maximum temperature takes account of the allowable tolerances inherent in thermostatic shower mixers and temperature losses.

**It is not a safe washing Temperature for adults or children.**

The British Burns Association recommends 37 to 37.5°C as a comfortable washing temperature for children. In premises covered by the Care Standard Act 2000, the maximum mixed water outlet temperature is 43°C.

## Products

Puro Mini Exposed and Concealed Thermostatic Dual Control Shower	PU90010CP
Puro Mini Exposed and Concealed Thermostatic Dual Control Shower with flexible slide rail kit	PU90014CP

## Check Content

Before commencing remove all components from packaging and check each component with the contents list.

Ensure all parts are present, before discarding any packaging. If any parts are missing, do not attempt to install your Inta shower valve until the missing parts have been obtained.

## Components

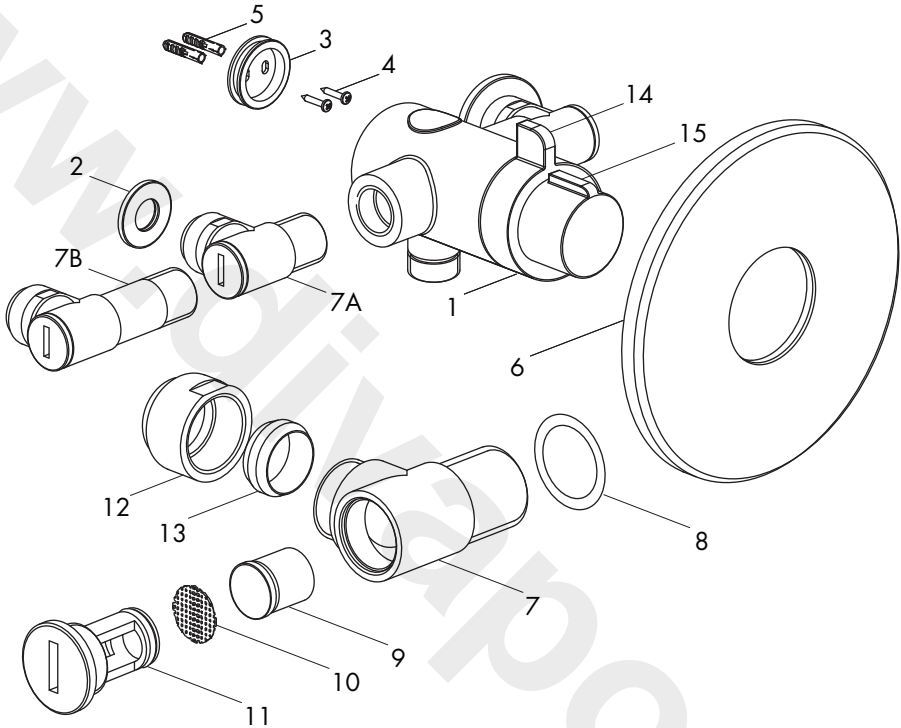

Item	Qty	Component	Item	Qty	Component
1	1	Shower Valve	8	2	'O' Ring
2	2	Concealing Plate - Exposed	9	2	Check Valve
3	1	Mounting Plate	10	2	Filter
4	2	Screws	11	2	Cap
5	2	Plastic Wall Plugs	12	2	Compression Nut
6	1	Concealing Plate - Concealed	13	2	Olive
7A	2	Elbow for 110 Centres	14	1	Flow Control Knob
7B	2	Elbow for 150 Centres	15	1	Temperature Control Knob

## Technical Data

The Puro Mini thermostatic shower valve is suitable for installations on all types of plumbing systems, including gravity supplies, fully pumped, modulating combination boiler, unvented water heater and unbalanced supplies i.e. Cold Mains & Tank Fed Hot. They are not suitable for non-modulating combination boilers.

Max. Working Pressure	5 bar	Max. Achievable Outlet	
Min. Working Pressure	0.2 bar	Temperature	41°C
Cold Water Temperature	5 to 25°C	Temperature Stability	±2°C
Hot Water Supply Temperature	55 to 65°C	Min Temp Differential to	
Max. Inlet Temperature	85°C	ensure fail-safe between hot	
Outlet Connections - Body	G½	and cold supplies	10°C

## Unvented Mains Pressure System

The drawing shows a typical installation of a shower mixing valve in conjunction with an unvented hot water system. This type of installation must be carried out in accordance with Part G of the Building Regulations.

Whilst pressures are theoretically equal (balanced) most unvented hot systems have a pressure reducing valve on the incoming cold water prior to the hot water storage vessel. This means that the hot and cold pressures can be significantly different.

Most unvented systems use an inlet manifold located directly after the pressure reducing valve.

It is recommended that the cold supply be taken from one of the outlets of the manifold directly to the shower as an independent supply.

For systems without a manifold unit after the pressure reducing valve and where the cold water supply pressure is significantly higher than the hot supply we recommend that a separate pressure reducing valve is fitted to the cold supply, as close as possible to the shower valve and with no draw off points between it and the shower valve.

Flow regulators are required for installations where a PRV is not fitted to ensure simultaneous demand is accounted for.

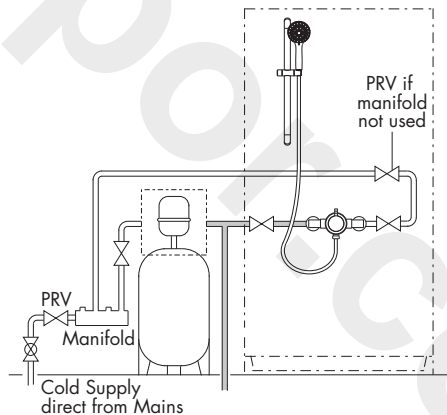

## Pumped Systems

Pumped systems use a booster pump to increase the pressure of the gravity fed water supplies.

These booster pumps are used where the head of water is insufficient to provide a satisfactory shower or where a high performance shower is required.

Please ensure that the performance of the pump is matched to suit the shower.

Follow the instructions for gravity fed installations taking into account the installation requirements of the pump.

Ensure that the hot and cold water storage capacity is sufficient to supply the shower and any other draw off points that may be used simultaneously.

Most pumps require a minimum head of water to allow the flow switches to operate automatically. Where this is not available a negative head kit may be required to operate the pump.

Please consult the pump manufacturer's installation requirements

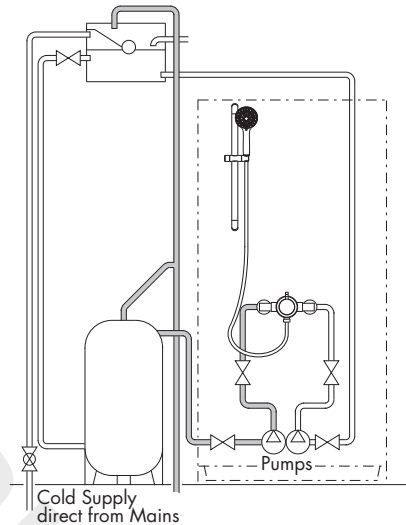

## Modulating Combi Boiler / Instantaneous Gas Water Heater

The drawing shows a typical installation of a shower valve in conjunction with a combination boiler.

Combi boilers will produce a constant flow of water at a temperature within its operating range. However we recommend that the system should supply hot water in excess of 60°C.

The hot water flow rates are dependant upon the type of boiler / heater used and the temperature rise required to heat the cold water to the required temperature.

The cold water flow rates may be much greater as they are generally unrestricted from the mains cold water supply. To ensure relatively balanced flow rates, we recommend that a pressure reducing valve or 6 l/min flow regulator is fitted in the cold water supply pipe.

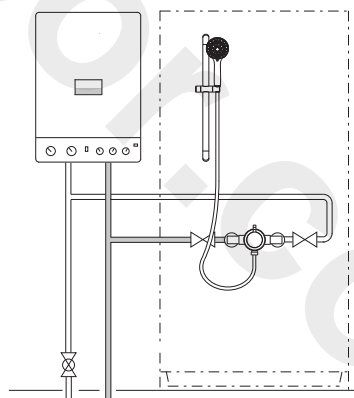

## Gravity System

The drawing shows a typical installation of a shower valve on a gravity supplied system.

Please note the minimum head pressure required to ensure correct operation of the valve. In accordance with good plumbing practice, we recommend that a totally independent hot and cold water supply be taken to the valve.

The cold water supply must be connected directly to the water cistern. The hot water supply should be connected to the hot water cylinder via an Essex flange or Sussex flange or to the vent or a draw off pipe as close as possible to the top of the cylinder.

For equal tank fed pressures there is no need to fit the flow regulators. This installation is the recommended minimum for gravity supplies.

For systems with less than 2 metre head pressure, we recommend that a suitable booster pump is fitted to increase the supply pressure.

### Cold Mains & Gravity Hot Supplies

If the cold supply to the shower is direct from the cold water mains and the hot water supply is gravity fed from the cold water cistern via the hot water cylinder you **MUST** fit a pressure reducing valve or a 6 l/min flow regulator.

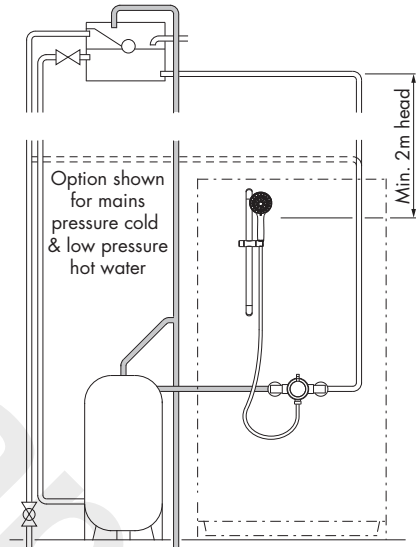

## Site Preparation - General

**It is important to plan the installation thoroughly to suit site conditions before commencing.**

- Before commencing the installation ensure site conditions are suitable.
- Depending upon the model, the shower valve is designed for exposed or concealed pipework, whether in a solid or studded wall.
- The thickness of wall tiles, plaster or plaster board should all be considered when positioning the shower valve and routing the hot and cold supply pipes.
- The concealed shower valve must protrude sufficiently from the finished tiled surface to allow the concealing plate and control handle to be fitted.
- Ensure the shower valve will be horizontal when installed.
- The supply pipes can come from below, above, the side or through the wall.
- Supplied with elbows to suit 110 or 150 centres, use the elbows to site conditions.

## Site Preparation - General

- The concealed shower valve must be installed securely into the wall. If not embedded into the wall with plaster the shower valve must be fixed secure to the studding using screws in the 2 mounting holes.
- Each shower valve is supplied with integral non return valves in the cold and hot inlet elbows to prevent cross contamination of the water supplies. Additional check valves may be necessary in certain circumstances to comply with the Water Regulations. With flexible hose kits, where the hand set is capable of falling within 25 mm of the top of the shower tray, additional backflow prevention devices may be required.
- Where possible, 22 mm hot and cold supplies should be used as close to the valve as possible and pipe runs should be kept to a minimum to maintain flow rates on low pressure installations.

**NOTE:** The inlets connections to the elbows to the shower valve are 15mm compression.

- The whole system should be thoroughly flushed, prior to connecting of the hot and cold water supplies to the shower valve, to remove any debris that may be in the supply pipework.
- Ensure there are no joint leaks before finishing the wall.
- Isolation valves must be fitted in an accessible position to both the hot and cold supplies should the valve need to be isolated in the future for servicing.

## Site Preparation - Exposed Valve

Ensure the hot and cold supplies are positioned correctly to connect to the shower valve and the main compression joints are accessible for future servicing.

When facing the shower valve the hot water supply should be on the left and the cold on the right.

Ensure the valve is positioned to allow the shower kit to be installed at the required height to suit the tallest user.

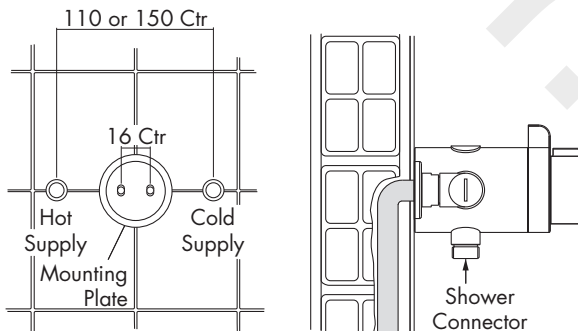

## Connection - Exposed Valve

Apply a bead of mastic to the back of the mounting back plate and fit to the wall in the required position using the appropriate wall plugs to suit the wall type.

The Puro Mini shower valve has a bottom ½" male shower connector, suitable for use with a flexible hose kit.

Fit the shower valve to the back plate and secure using the grub screw located at the bottom of the valve body.

Apply a bead of mastic to seal the joints around the hot and cold supply pipes and the joint between the wall and the mounting plate/valve.

Apply a bead of mastic to the outer edge, on the back of the two concealing plates and slide the plates over the supply pipes and press firmly to the wall.

Connect the hot and cold supplies to the valve using the 15mm compression joints and check the joints for leakage.

The elbows are designed to allow access to the filters and check valves without the need to disconnect the valve from the pipework.

Check the function of the valve, the maximum temperature should not exceed 43°C.

## Site Preparation - Concealed Valve

Prepare the cavity to receive the valve, ensure the hot and cold supplies are positioned correctly and isolation valves are fitted in an accessible position.

When facing the shower valve the hot water supply should be on the left and the cold on the right.

Fit the back plate to the wall using the wall plugs and screws provided. Different wall plugs may be required to suit the wall construction.

In a stud wall it may be necessary to fit a batten to support the valve.

Ensure the valve is positioned to allow the shower kit to be installed at the required height to suit the tallest user.

Depth of cavity must be sufficient to conceal most of the valve body and pipework to the finished wall surface including wall tiles. Ensure sufficient valve body will protrude from the finished wall surface to allow the concealing plate to be position correctly.

Ensure the second outlet is blanked off if not used.

## Site Preparation - Concealed Valve

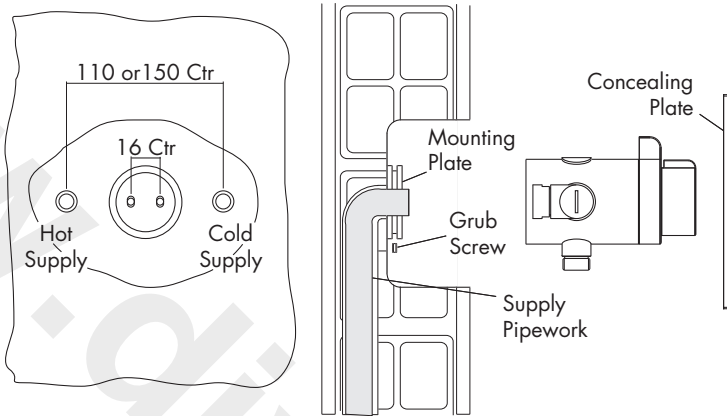

**NOTE:** Wall elbow available for concealed installation for use with flexible hose shower kit.

## Connection - Concealed Valve

The Puro Mini shower valve has both a bottom and top  $\frac{1}{2}$ " female connection, ensure the blanking plug is fitted into the outlet which is not required and tighten to make a water tight joint.

Fit the shower valve to the back plate and secure using the grub screw located at the bottom of the valve body.

The elbows (7A or 7B) can be rotated to suit top or bottom water supplies.

Connect the hot and cold supplies to the valve using the compression joints provided.

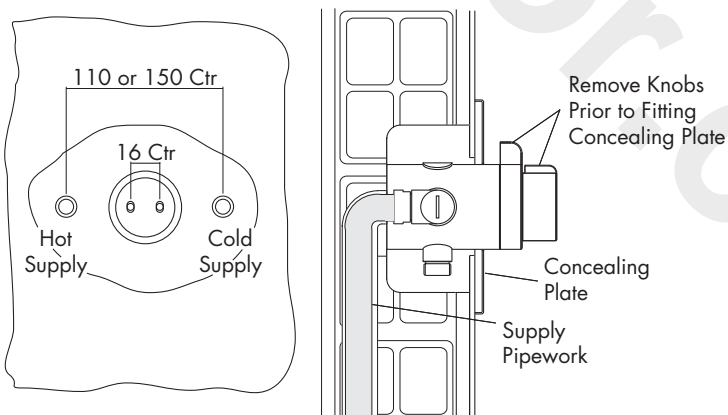

## Connection - Concealed Valve

The elbows are designed to allow access to the filters and check valves but with a concealed installation this is not possible. It is therefore recommended to remove these items before installation and provide filters, check valves and services valves in the supply pipes in an accessible location where cleaning and maintenance can be conducted easily.

Turn on the water supplies and check for leaks.

Check the function of the valve, the maximum temperature should not exceed 43°C.

## Concealed Valve - Fitting the Concealing Plate

Once the valve has been installed, all the connections have been checked for leakage and the surface of the wall has been finished the concealing plate can be fitted.

With both control knobs in the vertical position pull off the knobs from the shower valve.

Apply a bead of mastic to the outer edge, on the back of the concealing plate and slide the plate over the valve body and press firmly to the wall.

Refit the control knobs to the shower valve in their original vertical position.

## Filter Cleaning

Should the filters in the inlet elbows require cleaning or the check valves require cleaning isolate the water supplies to the shower valve.

Unscrew the cap at the end of the elbow and remove the filter, flush thoroughly with clean running water, replace if damaged.

The check valve can also be removed for cleaning again flush thoroughly with clean running water, replace if damaged.

Refit the cap and tighten.

## Aftercare

Inta shower mixing valves have a high quality finish and should be treated with care.

An occasional wipe with a mild washing-up liquid on a soft damp cloth followed by a thorough rinsing is all that is required.

The nozzles in the hand set should be cleaned periodically to remove any build up of debris or deposits which may affect the performance of the shower.

**Do not use an abrasive or chemical household cleaner as this may cause damage.**

## Spares

A full range of spares are available for this product.

**PLEASE NOTE:** Only genuine spares should be used.

## Problem Solving

The following details are supplied for on site queries, should you require any further assistance our Technical Department can be contacted directly on 01889 272199.

Fault	Solution
Showering temperature is not hot enough.	Ensure the hot water supply is at a constant temperature above 60°C. Check for air locks in the pipework.
The water goes cold during showering.	Insufficient stored hot water. When used with a combi boiler confirm that the boiler is still firing. Adjust the boiler to a minimum setting of 65°C which may not necessarily be the best flow rate.
When the water is set at cold, the showering temperature is too hot.	The hot and cold supply connections have been made in reverse.
The maximum showering temperature is too hot or when set to hot water runs to cold.	Check the position of the temperature control knob, rotate clockwise to lower the temperature. Check the connections to the valve have not been made in reverse.
The flow of water from the shower valve is low.	Check the filters are clean and the supply pressure is above 0.2 bar.
No flow of water	Ensure the valve has not fail-safed and check that there is hot and cold water flow to the valve. Ensure the check valves are not closed.

## Flexible Slide Rail - Components

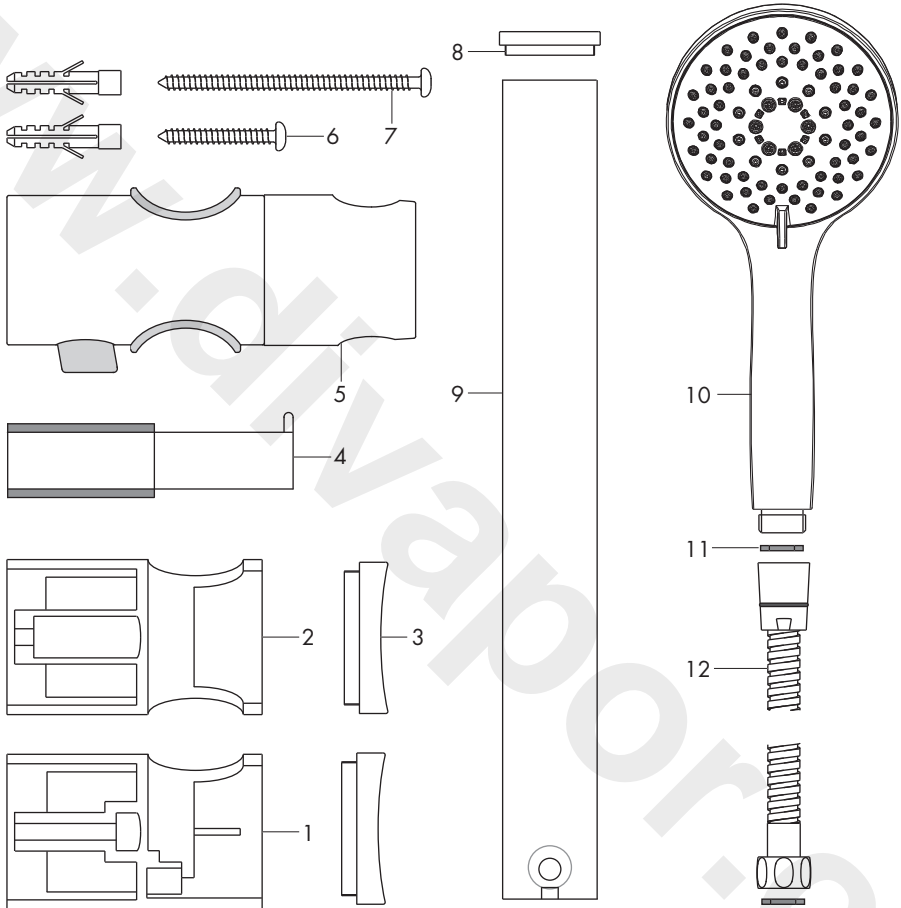

Item	Qty	Component	Item	Qty	Component
1	1	Bottom Wall Bracket	7	1	M4 x 30 Screw & Plug
2	1	Top Wall Bracket	8	1	Rail Cap
3	2	Cover	9	1	Rail
4	1	Flexible Tidy	10	1	Handset
5	1	Handset Holder	11	2	Sealing Washers
6	1	M4 x 70 Screw & Plug	12	1	Flexible Hose

## Slide Rail - Installation

The screws and wall plugs supplied are only suitable for use in solid walls. If the wall is plaster board or soft building block use special wall plugs obtainable from most DIY stores.

Ensure there are no supply pipes or cables where you intend to drill.

Where possible, drill holes between ceramic tiles (in the grout). If drilling into ceramic tiles use a ceramic bit.

This product must always be used and fitted in such a way as not to cause water damage, therefore should be located and directed towards a suitable shower tray.

Take care to use power tools safely.

Carefully remove the cover (3) from each wall bracket (1) and (2) to expose the fixing hole.

Drill the 6mm diameter hole for the bottom wall bracket (1).

To avoid cracking ensure the wall plug is pushed all the way behind the ceramic tile.

Using the 70mm long screw (7) provided temporarily secure the wall bracket (1) to the wall ensuring the correct orientation for the bracket.

Slide the top wall bracket (2) onto the riser rail (9) and position in the bottom wall bracket (1) ensuring that the slot at the bottom of the riser rail is located over the anti-rotational lug.

Locate the upper bracket onto the wall towards the upper end of rail, approximately 50mm from the end, ensuring the rail is vertical.

Mark round the upper wall brackets with a removeable marker onto the wall.

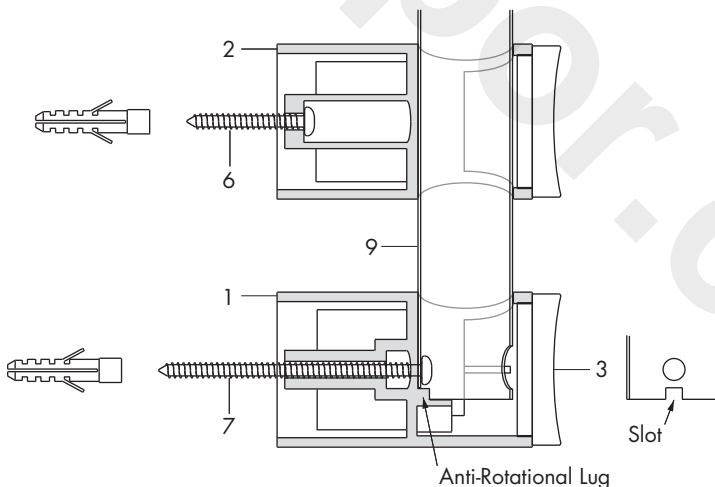

## Slide Rail - Installation

Position the top wall bracket (2) onto the wall within the markings and using the hole as a template, drill a 6mm diameter hole.

Fix the upper wall bracket to the wall using the 30mm long screw and secure.

Assemble the end cap (8) into the end of the rail without horizontal hole.

Assemble the handset holder (5) and the flexible tidy (4) onto the riser rail below the handset holder.

Unscrew the 70mm long screw (7) and remove from the bottom wall bracket (1).

Pass the rail assembly through the hole in the top wall bracket (2) and locate in the bottom wall bracket (1) ensuring that the slot at the bottom of the riser rail is located over the anti-rotational lug.

Pass the 70mm long screw through the hole in the rail and through the wall bracket and secure.

The head of the screw should be inside the rail as shown.

Refit the covers (3) into the wall brackets

Ensure the sealing washers (11) are inserted into both ends of the flexible hose (12) and connect the hose to the shower valve and the handset (10).

Turn on the shower valve and check joints for leakage.

## Slide Rail - Dimensions

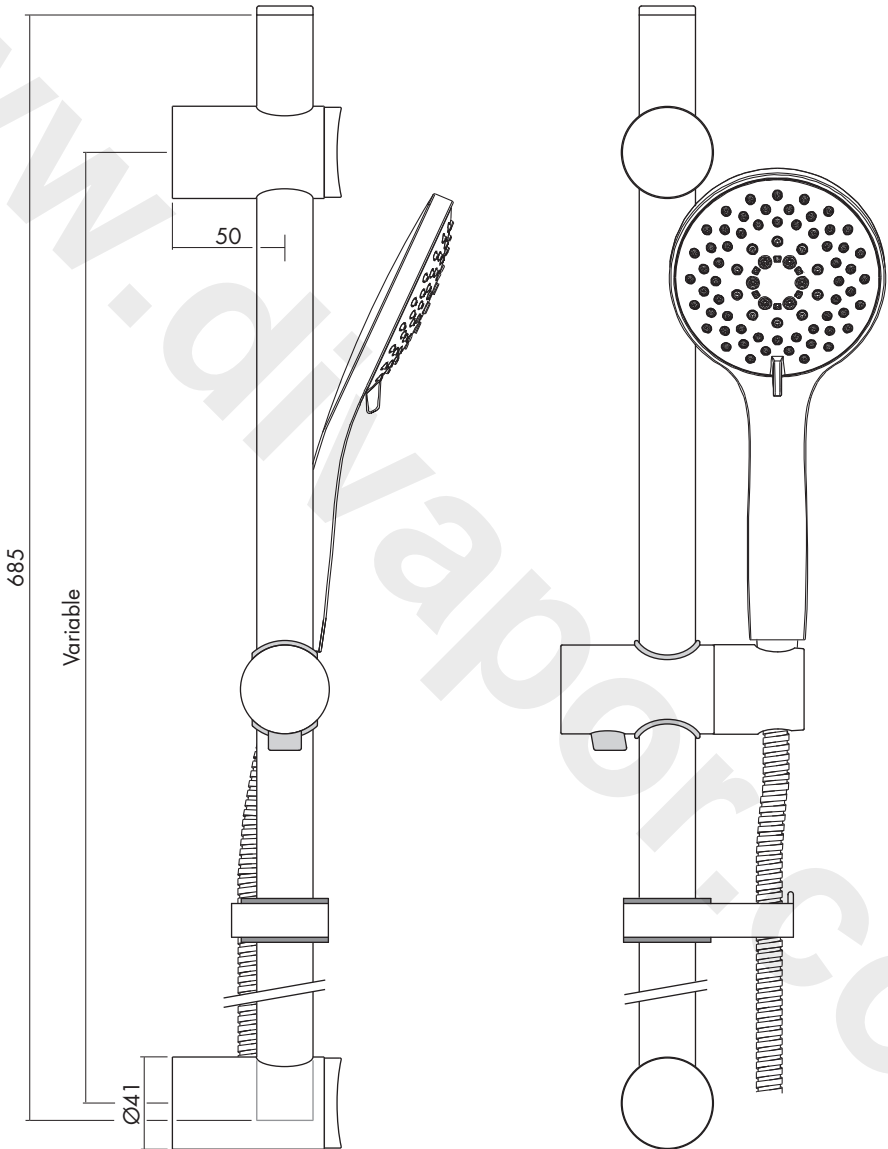

## TMV2 Installation Instructions

The following information is required when the thermostatic mixing valve is used in a TMV2 Applications under the requirements of BS EN 1111:1999 "Sanitary tapware – Thermostatic Mixing Valve (PN 10) – General Technical Specification"

### Introduction

The thermostatic shower valve has been specifically designed and manufactured to meet the requirements of BS EN1111:1999 TMV2 Type Scheme. The valve has been independently tested and approved as a TYPE 2 valve under the BuildCert TMV2 scheme by the WRc - NSF Testing & Evaluation Center.

### Supply Conditions

The supply conditions to the Thermostatic Mixing Valve must comply with the following;

Conditions	High Pressure BS EN 1111
Maximum Static Pressure	10 bar
Flow Pressure, Hot & Cold	0.5 to 5 bar
Hot Supply Temperature	55 to 65°C
Cold Supply Temperature	≤ 25°C
Temperature Stability	± 2°C
Min Temp Differential (Mix to Hot) for fail-safe	10°C
Max. Pressure Inlet Differential	5:1

**Note:** Valves operating outside these conditions cannot be guaranteed by the Scheme to operate as type 2 valves.

### Approvals

Buildcert Scheme Approval Number:

Details Available on Request

WRAS Scheme Approval Number:

Details Available on Request

### Application

The thermostatic shower mixer has been independently tested by WRc - NSF and certified as meeting the requirements of the BS EN 1111:1999 under the TMV2 Scheme as being suitable for use on the following designations.

Shower

**HP**

## Recommended Outlet temperatures

The BuildCert TMV scheme recommends the following set maximum mixed water outlet temperature for use in all premises:

Application	Recommended Hot Water Temperature
Shower	41°C

The mixed water temperature must never exceed 43°C.

The maximum mixed water temperature can be 2 °C above the recommended maximum set outlet temperature.

**Note:** 43°C is the maximum mixed water temperature from a shower mixer. The maximum temperature takes account of the allowable tolerances inherent in thermostatic shower mixers and temperature losses.

### **It is not a safe bathing Temperature for adults or children.**

The British Burns Association recommends 37 to 37.5°C as a comfortable bathing temperature for children. In premises covered by the Care Standard Act 2000, the maximum mixed water outlet temperature is 43°C.

## Installation

**Important:** - The following instructions must be read prior to the installation of the thermostatic shower valve. The installer of the thermostatic shower valve must comply with the requirements of the Water supply (Water Fittings) Regulations 1999 and also be aware of their responsibility and duty of care to ensure that all aspects of the installation comply with the regulations.

It has been brought to our attention that flushing water systems using certain chemicals may wholly or partially remove the lubricant from the internal workings of the valve, which may adversely affect its performance. We recommend that following flushing the system with chemicals; valves are checked for correct operation.

1. It is essential that before installing any thermostatic shower valve to ensure that the supply conditions of the system to which the valve is intended to be fitted are checked to confirm compliance with the parameters as quoted within the technical specification and conditions on which the approval is granted i.e. verify supply temperatures, supply pressures, risk assessment.
2. Consideration must be made for the possibility of multiple / simultaneous demands being made on the supply system whilst the thermostatic shower valve is in use, all practical precautions must be made to ensure that the valve is not affected. Failure to make provision within the pipe sizing etc. will affect the performance of the shower valve.

## Installation

3. The supply to which the thermostatic shower valve is to be installed must be thoroughly flushed and cleaned to remove any debris, which may have accumulated during the installation. Failure to remove any debris will affect the performance and the manufacturer's warranty of the product. In areas that are subject to aggressive water, provision must be made to treat the supplies prior to the supplies entering the shower valve.
4. The thermostatic shower valve has been designed for horizontal installation and surface mounting.
5. The thermostatic shower valve will be installed in such a position that maintenance of its components, associated valves and the commissioning and testing of the shower valve can be undertaken.
6. The hot and cold water supplies must be connected to the valve strictly in accordance with the indications on the body of the valve i.e. hot water supply to the hot port of the valve.
7. In a situation where one or both of the water supplies are excessive, it is recommended to fit a Pressure Reducing Valve to reduce the pressure(s) to within the limits as quoted previously.
8. Any thermostatic shower valve must be fitted with a back flow prevention device, such as check valves to prevent the cross contamination of supplies. The thermostatic shower valve is supplied complete with integral insert check valves and strainers.
9. Isolation valves in an accessible position are required as close as is practicable to the water supply inlets of the thermostatic shower valve.
10. The fitting of strainers is recommended as close as is practicable to the water supply inlets of the thermostatic shower valve.
11. It is essential that the fail safe thermostatic shower valve should not be installed in situations where there is a possibility of the valve being deprived of water or where demands for water are greater than the actual stored supplies.
12. To ensure that the performance levels of the thermostatic shower valve are maintained (in the event of cold water failure), the temperature of the hot water supply at the point of entry to the thermostatic shower valve must be a minimum of 10°C above the commissioned mixed water discharge temperature.
13. The fail-safe thermostatic shower valve must not be subject to any extreme temperature variations either during the installation or under normal operating conditions.

## Commissioning

**Important:** - The following instructions must be read and understood prior to commissioning the thermostatic shower valve. If under any circumstances there are aspects to the installation / system which do not comply with the specification laid down, the valve **MUST NOT** be put into operation until the system / installation complies with the specification. However if all these conditions are met, proceed to set the temperature as follows;

1. Ensure that the system is thoroughly cleaned and free from any debris prior to commissioning the thermostatic shower valve.
2. Commissioning the temperatures must be carried out using a suitably calibrated thermometer, preferably a digital thermometer. The sensing part of the thermometer probe must be fully submerged in the water when testing.
3. The valve must be commissioned taking into consideration any fluctuations, which may occur within the system due to simultaneous demands. It is advisable that any outlets which are connected to the same supply as the shower valve are open during setting of the mixed water temperature. It is advisable to ensure that the water temperatures are established before any attempt to commission.
4. Once the supply temperatures are stable and the normal operating conditions are established, the shower valve can be commissioned. The following sequence should be followed when commissioning the valve;
  - 4.1 The first step in commissioning a thermostatic shower valve is to check the following:
    - The designation of the thermostatic shower valve matches the application
    - The supply pressures are within the valve's operating range.
    - The supply temperatures are within the valve's operating range.
    - Isolating valves (and 'Y' strainers preferred) are provided.
  - 4.2 If all these conditions are met, proceed to set the temperature following the procedure described earlier in the Calibration section.
  - 4.3 Measure and record the temperature of the hot and cold water supplies at the connection to the valve.
  - 4.4 Measure and record the temperature of the water discharging from the valve.
  - 4.5 Isolate the cold water supply to the valve and monitor the mixed water temperature.
  - 4.6 Measure and record the maximum mixed water temperature and the final temperature. The final temperature found during the test should not exceed the values quoted.
  - 4.7 Record all the equipment used during the commissioning.
  - 4.8 The mixed water temperature at the terminal fitting must never exceed 2°C above the set temperature.

## Commissioning

5. If the mixed water temperature exceeds the recommended temperature of 41 °C by 2 °C or does not reach 41 °C the shower valve can be adjusted as follows:
  - 5.1 With normal supply conditions established and the hot and cold water supplies running, open the shower valve to its maximum temperature and leave running.
  - 5.2 Remove the indice, retaining screw and handle.
  - 5.3 The temperature stop rings are used to control the temperature, ring A the hot and B the cold water, see diagram on page 12.
  - 5.4 Remove both rings from the cartridge and set the mixed water to the required temperature, maximum 41 °C.
  - 5.5 Temporarily refit the handle and using a digital thermometer it is possible to increase or reduce the mixed water outlet temperature until 41 °C is re-established, by slowly rotating the handle.
  - 5.6 The stop rings are used to set the temperature limits of the shower when in use. When the required temperature is achieved replace the two stop rings on the splined spindle.
6. The above information must be recorded and updated on every occasion when any work is carried out on the valve.

## In Service Testing

It is a requirement that all TMV2 approved valves shall be verified against the original set temperature results once a year. When commissioning / testing is due the following performance checks shall be carried out.

1. Measure the mixed water temperature at the outlet.
2. Carry out the cold water supply isolation test by isolating the cold water supply, wait for five seconds if water is still flowing check that the temperature is below 43 °C.
3. If there is no significant change to the set outlet temperature ( $\pm 2^\circ\text{C}$  or less from the original settings) and the fail-safe shut off is functioning, then the valve is working correctly and no further service work is required.

### Notes:

- If there is a residual flow during the commissioning or the annual verification (cold water supply isolation test), then this is acceptable providing the temperature of the water seeping from the valve is no more than 2 °C above the designated maximum mixed water outlet temperature setting of the valve.
- Temperature readings should be taken at the normal flow rate after allowing for the system to stabilise.
- The sensing part of the thermometer probe must be fully submerged in the water to be tested.
- Any thermostatic shower that has been adjusted or serviced must be re-commissioned and re-tested in accordance with the manufacturers' instructions

---

**Notes**

www.divapor.com

## Notes

www.divapor.com

## Notes

www.divapor.com

# inta

---

Please leave this Manual for the User

To activate your product warranty please visit  
**[www.intatec.co.uk](http://www.intatec.co.uk)**  
and click on Product Registration

# inta

**Intatec Ltd**

Airfield Industrial Estate  
Hixon  
Staffordshire  
ST18 0PF

Tel: **01889 272 180**

Fax: **01889 272 181**

email: **[sales@intatec.co.uk](mailto:sales@intatec.co.uk)**

web: **[www.intatec.co.uk](http://www.intatec.co.uk)**

E & O.E

© Intatec Ltd 2015

29-09-15