

AFTERCARE INSTRUCTIONS

Your fitting has a high quality finish and should be treated with care to preserve the visible surfaces. All surface finishes will wear if not cleaned correctly, the only safe way to clean your mixer is to wipe with a soft damp cloth. Stains can be removed using washing up liquid. All bath cleaning powders and liquids will damage the surface of your fitting even the non-scratch cleaners.

GUARANTEE

All products are manufactured to the highest standards and a 5 year guarantee covers any defect in manufacture. As gold and special effect finishes are softer than chromium plate, special care must be taken when cleaning; a 3 year guarantee covers these.

NOTE: The 5 year guarantee on the valves is invalidated if damaged by any waterborne debris.

In the interests of continuous product development Bristan reserve the right to alter specification as necessary.

PRODUCT CODE: PM 3HBAS C / SAT / ST

TELEPHONE HELP LINE: 0844 701 6273

Bristan Group Ltd
Birch Coppice Business Park
Dordon
Tamworth
Staffordshire
B78 1SG
UK
A Masco Company

Web Site: www.bristan.com

Telephone: 0844 701 6273

Facsimile: 0844 701 6275

Email: enquire@bristan.com

(F1 PM 3HBAS)

(D3)

(ST)

BRISTAN

Prism 3 Hole Basin Mixer

Fitting Instructions & Contents List

**Please keep these instructions for future reference
and for the ordering of spare parts.**

WATER PRESSURE

This mixer is suitable for use at all supply pressures. However for optimum use both the hot and cold supplies should be reasonably balanced. If the fitting is installed at low pressure (tank fed), then the minimum distance from the outlet of the nozzle to the underside of the cold tank should be 1.8 metres to ensure adequate performance. This mixer should be installed in compliance with Water Regulations. Where the supplies are unbalanced, i.e. hot water from the cylinder tank / cold from the mains, approved check valves must be fitted in the supply pipes. For further details contact your Local Water Authority.

INSTALLATION

1. Identify all the components and check for completeness, particularly before arranging installation.
2. Fit the center nozzle (9) and side bodies (5) to the basin using the nuts (4), washers (2) and cover flanges (1).
3. N.B. the handles (12) may need to be removed before fitting the side bodies (5), to do this remove the handle lever (14) and loosen the grub screw (13) behind it using the 2.5mm hexagon key supplied.
4. Fit the center tee (8) and pop-up rod (10) to the nozzle (9)..
5. Connect center tee (8) to side bodies (5) using flexible hoses (7) and washers (6) (looping hoses to fit as shown in diagram).
6. Fit the valves (3) to the side bodies (5), (if not already fitted).
7. Re-fit the handles (12) using the hexagon key supplied.
8. Fit the waste.
9. Fit the pop-up waste rod and connect it to the waste, adjust to open and close.
10. Connect hot and cold supplies; fully open both valves, letting them run for a few minutes to check all joints and connections for leaks.
11. See over the page for aftercare instructions.

MAINTENANCE

If the fitting begins to drip:

1. Turn off the water supply.
2. Unscrew handle lever (14), loosen grub screw (13) with 2.5mm hexagon key and pull off head (12).
3. Remove valve (3).
4. Carefully clean seating, rubber washer and ceramic disc.
5. Replace valve and head and turn on the water supply.
6. Contact our helpline if problem persists.

CONTENTS

1. Cover Flange (x2)	6. Washers (x4)	11. Knob (x1)
2. Washers (x6)	7. Flexible hose (x2)	12. Head (x2)
3. CD Valves (x2)	8. Center Tee (x1)	13. Grub Screw (x2)
4. Back Nut (x3)	9. Spout (x1)	14. Handle Lever (x2)
5. Side Body (x2)	10. Operating Rod (x1)	

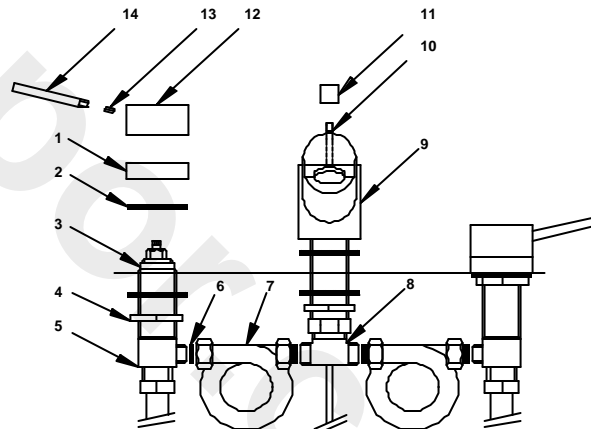

Please Note: In the unlikely event you find a part missing please contact our customer Service Help line on 0844 701 6273 for immediate dispatch of part.