

Non Concussive Shower with Temperature Control

NC140CP

Installation and Maintenance

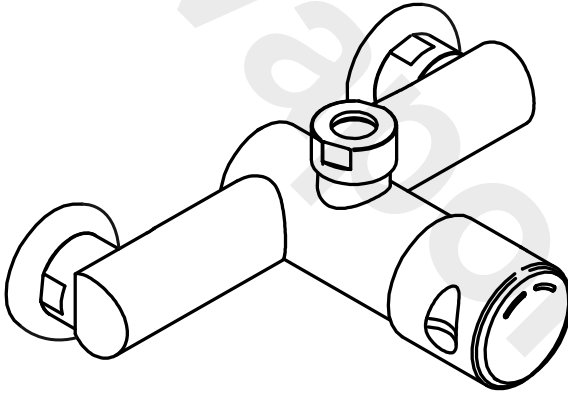

In this procedure document we have endeavoured to make the information as accurate as possible. We cannot accept any responsibility should it be found that in any respect the information is inaccurate or incomplete or becomes so as a result of further developments or otherwise.

Operating Conditions

Min Operating Press.	0.5 bar
Max Operating Press.	5.0 bar
Max Temperature	65°C
Timed Flow @ 1 bar, 20 ±5°C	15 ± 3

General information

The NC140CP is a non concussive shower control with manual temperature adjustment.

Turn the control knob clockwise to increase the mixed water temperature and anti-clockwise to reduce it.

Push the control knob to operate the shower.

Installation

Your Inta shower control must be installed in accordance with the Water Byelaws.

In order to prevent scalding, the hot water supply should be connected to the mixer via a thermostatic mixing valve

It is recommended that a service valve is installed in the cold water supply pipe and the thermostatic mixing valve should have connections containing an isolating valve, in order to isolate the mixer should servicing be required in the future. All installations should be thoroughly flushed and cleaned to remove any debris that may affect the performance of the mixer. This product is designed for concealed pipework, whether in a solid or studded wall.

- The thickness of wall tiles, plaster or plaster board should all be considered when routing the hot and cold supply pipes.
- The shower requires the offset connectors to have 150mm centres and sufficient thread must protrude from the finished surface to allow the concealing plates to be fitted and the union nuts to be fully tightened.
- Ensure the shower will be horizontal when installed.
- The supply pipes can come from below, above, the side or through the wall.
- The supply pipes and offset connectors must be firm and secure to support the shower. If not embedded into the wall with plaster the pipes should be fixed securely to the studding or by using a mounting plate (not supplied).
- Angle tap swivel connectors or compression/solder fittings can be used to connect the pipes (not supplied).
- The whole system should be thoroughly flushed, prior to the connection of the hot and cold water supplies to the shower, to remove any debris that may be in the supply pipework.
- Ensure there are no joint leaks before finishing the wall.
- Isolation valves must be fitted in an accessible position to both the hot and cold supplies should the valve need to be isolated in the future for servicing.

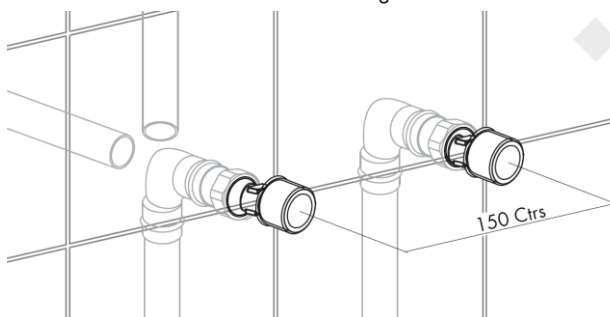

- Seal the gaps between offset connectors and tiles with mastic.
- Place the concealing plates, with a bead of mastic on the back, over the hot and cold offset connectors and press firmly to the wall.
- Fit the shower valve to the offset connectors ensuring that the sealing washers are fitted and hand tighten the union nuts.
- Using a suitably sized spanner, tighten the union nuts taking care not to damage the finish on the shower valve, do not over tighten.

Operation

To operate the shower push the control knob until it contacts a stop and then release, mixed water will then flow for approximately 15 seconds.

Rotating the control knob anticlockwise progressively closes the hot water port and opens the cold water port until it is fully open when only flows through the shower.

Rotating the control knob clockwise progressively closes the cold water port and opens the hot water port until there is only hot water flowing through the shower

Aftercare

Inta products have a high quality finish and should be treated with care.

An occasional wipe with a mild washing-up liquid on a soft damp cloth followed by a thorough rinsing is all that is required.

Do not use an abrasive or chemical household cleaner as this may cause damage.

Servicing Instructions

If the control knob cannot be depressed fully or does not return to its original position within 15 seconds, or the temperature cannot be adjusted easily or water does not flow in a steady stream the mixer may need require servicing.

Isolate the hot and the cold supplies
Remove the cover, unscrew the retaining screw and carefully remove the control knob ensuring the return spring does not escape and cause injury. Using a spanner remove the cartridge from the body. Remove any debris that may have collected within the body, ensure the stem rotates freely and can be depressed.

Do not attempt to dismantle any part of the cartridge, if necessary replace with a new cartridge.

Check the o rings and return spring for any sing of damage and replace if necessary.

Using washing up liquid as a lubricant, to ease assembly and prevent damage to the o rings, re-assemble the cartridge into the body and tighten. Re-assemble the other components in the reverse order and turn on the water supplies. Check the shower for leaks and correct operation

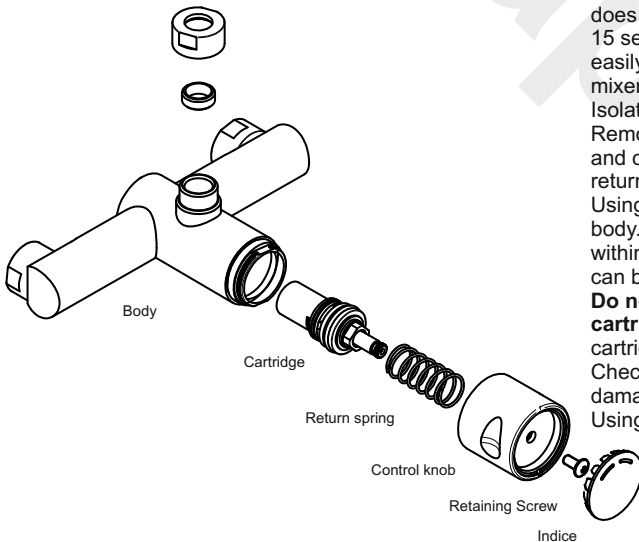
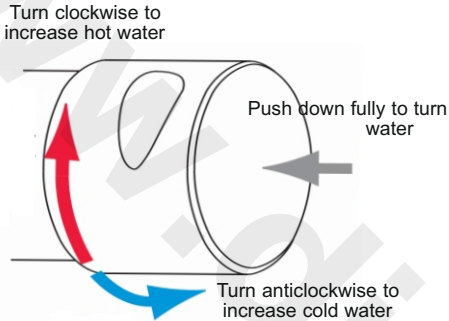

www.divapor.com

inta

Intatec Ltd,
Airfield Industrial Estate
Hixon
Staffordshire
ST18 0PF
Tel: 01889 272 180
Fax: 01889 272 181
email: sales@intatec.co.uk
web: www.intatec.co.uk