

For any further information please contact
Crosswater on: **0845 873 8840**

Or visit our web-site at www.crosswater.co.uk

The manufacturer reserves the right to make technical
modifications without prior notice.

INSTALLATION INSTRUCTIONS

INTRODUCTION

This thermostatic valve is suitable for use with all water systems up to a maximum operating pressure of 5.0 bar, (beyond which we recommend pressure reducing valves to be fitted).

The thermostatic valve has two outlets that can be controlled simultaneously.

The two main outlets are controlled by the flow control cartridges, commonly used for a main shower head and a bath spout.

PARTS IDENTIFICATION

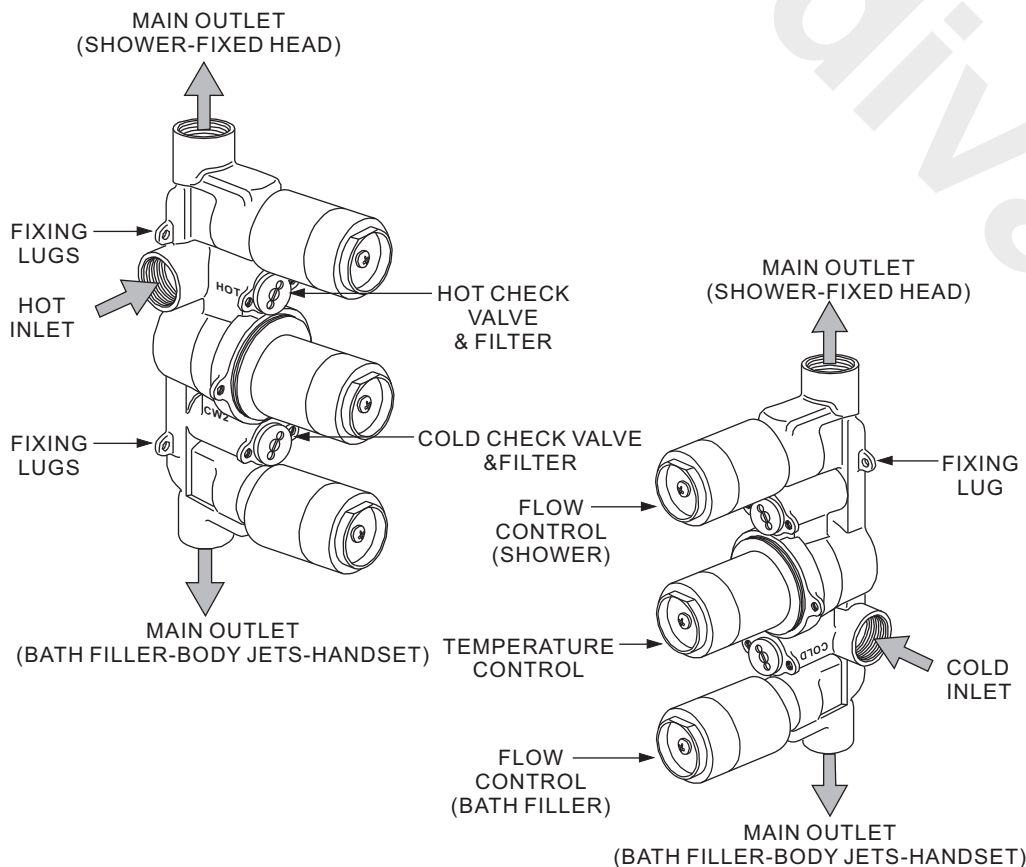

NOTE: FOR ILLUSTRATIVE PURPOSES HANDLES ARE NOT SHOWN

DIMENSIONS

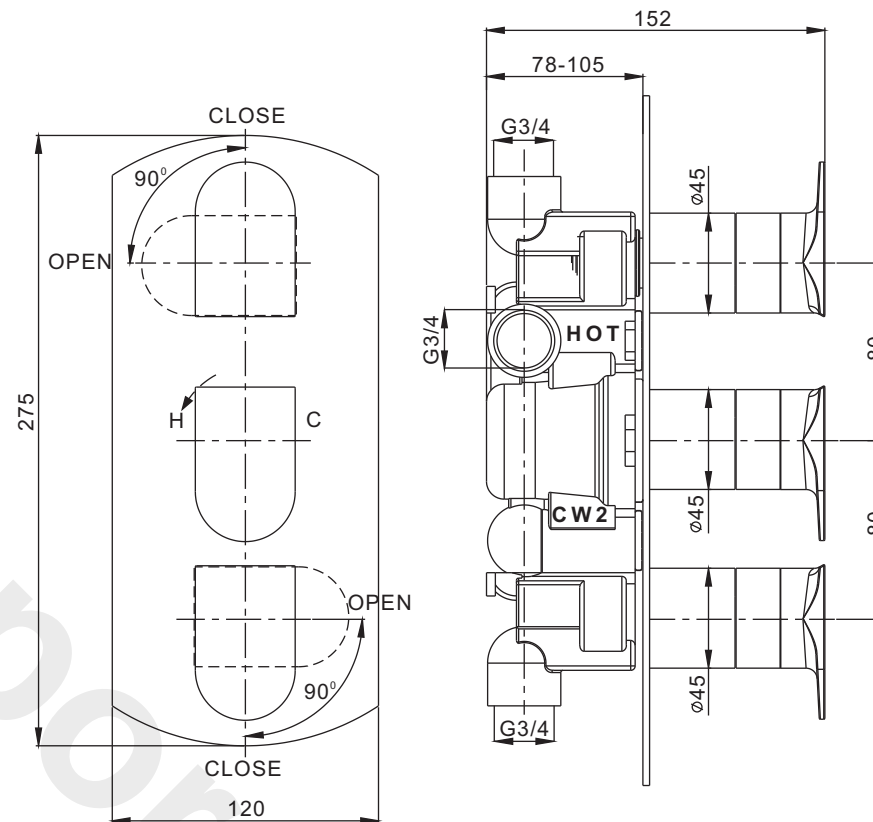

TMV APPROVED INSTALLATIONS

This thermostatic valve has been designed to be compliant with the requirements of TMV2. NB for installations governed by this legislation the CW marking (as pictured on valve above) must always be left visible for the commissioning process.

No liability for installation costs will be accepted if, for example, the tiling is too close to the body of the valve or expanding foam is used preventing the marking of the valve being visible. Once the inspection has been carried out the cover plate can be fitted.

NOTE: ALL DIMENSIONS IN MILLIMETRES

INSTALLATION

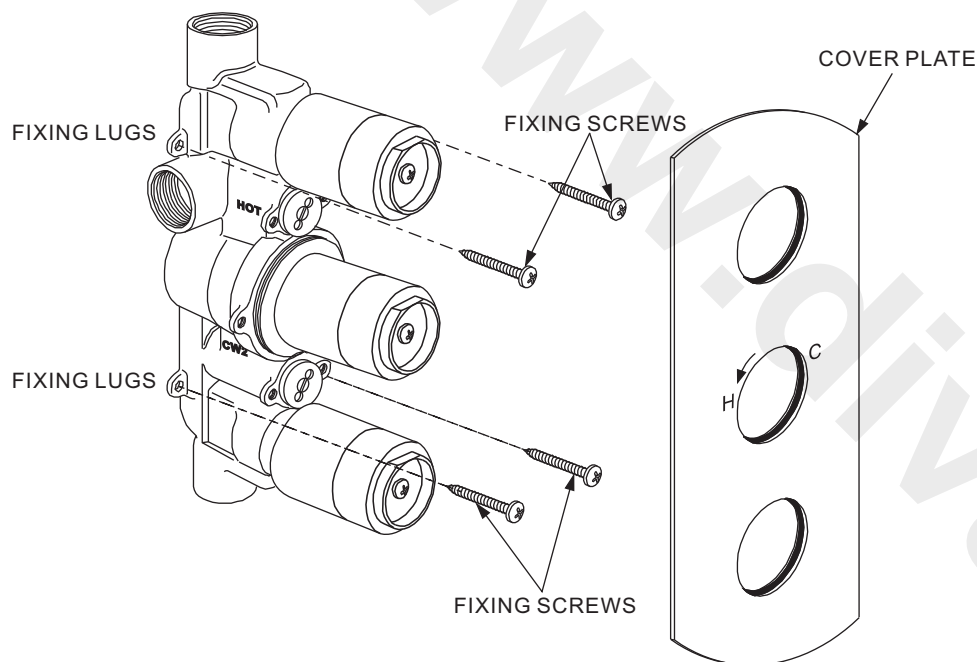

FIG. 1 FITTING PLASTIC DUST COVER

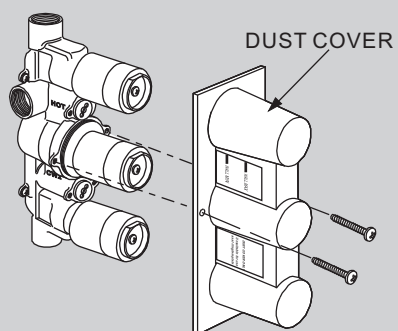
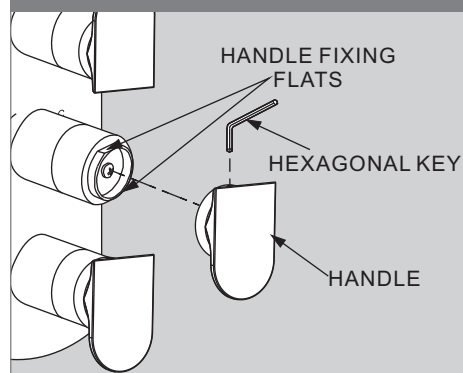

FIG. 2 FITTING CONTROL HANDLES



INSTALLATION

NOTES:

Please read these instructions carefully and keep in a safe place for future reference. The installation must comply with all Local/National Water Supply Authority Regulations/Bye laws and Building and Plumbing Regulations (UK: BS6700). This valve is a mixing device and therefore requires the water supplies to be reasonably balanced, otherwise we recommend a pressure reducing valve to be fitted.

The valve is fitted with integral WRC approved single check valves cartridges which command the water supply, therefore the thermostatic valve is protected against cross-flow due to unbalanced line pressures as required by the Water Supply (Water Fittings) Regulations 1999.

Fitting isolating valves to the inlet feeds is recommended for ease of maintenance.

INSTALLATION

- ⚠ **Remember to turn off the mains water supply before connecting to any existing pipe work.**
- ⚠ **Warning! Please check for any hidden pipes and cables before drilling holes in the wall.**

Position the valve onto the wall and mark the position of the fixing lugs (x4). Make sure the valve is set back from the front face of the wall by the appropriate depth to allow for plasterboard, filling and tiling etc. (min. 78mm to max. 105mm see dimension page).

Mount casting to the wall using suitable fixings.

Always leave access to the four front cartridges for servicing.

Once the valve has been secured to the wall, the black Plastic Dust Cover can be temporarily attached to the valve with the screws supplied. This will protect the valve while the rest of the work is completed (**PLEASE DO NOT TILE UP TO GUARD**- Fig 1).

Inlets and outlets are all tapped 3/4" BSP. Make all pipe work connections using a proprietary thread sealer.

Do not use tapered threaded adaptors.

Blank off and seal the open outlet if it is not required.

Remove the Plastic Dust Cover.

Turn on supplies and test all connections for water tightness.

Remove Hot and Cold check valves, and flush out the installation, clean the filters and refit.

Apply a narrow bead of clear silicone sealant around the back edge of the cover plate and carefully press into position.

Fit the control knobs by lining up the flat surface of the valve cover with the grub screw on the handle, tighten the screw with the supplied hexagonal key (**see fig 2**).

TEMPERATURE SETTING

To set the temperature, remove the handle and unscrew the centre screw of the thermostatic control cover. Rotate the exposed thermostatic spindle (clockwise for cold, and anti-clockwise for hot) until the maximum desired showering temperature is set (42°C-suggested maximum "pre-set" temperature).

Then line up the screw head on the back of the thermostatic control cover with the first stop on the stop ring itself. Push the control cover onto the splines and tighten the centre screw, refit the handle. The thermostat is now set to its new temperature and can only be increased or decreased by repeating this process.

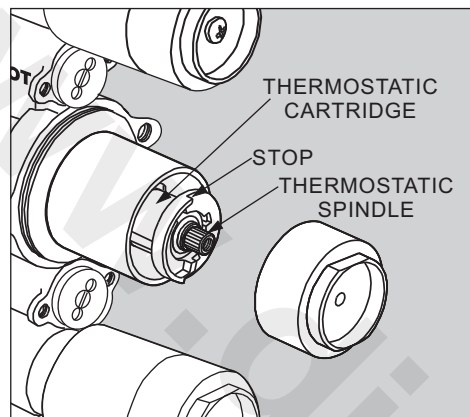

MAINTENANCE

Note: To avoid damage, please remove all chrome parts before any maintenance takes place.

THERMOSTATIC CARTRIDGES

The 1" concealed thermostatic valve should give trouble free service, but in the event of failure, servicing is straight forward.

To remove the thermostatic cartridge.

Undo the cartridge clamp nut (take note of the orientation of the cartridge) and pull the cartridge out using the temperature control knob to aid removal. Wash the cartridge with clean running water and make sure that any trapped debris has been removed. Dry and lightly grease the seals (only use silicone grease) and replace the cartridge making sure that the locating lug is located in the recess on the hot side of the valve.

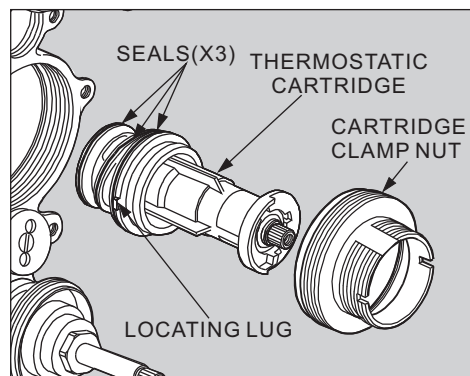

FLOW CONTROL CARTRIDGE

The Flow Control Cartridge uses ceramic discs which normally last indefinitely unless debris manages to get between them. Wash the cartridge with clean running water, dry and lightly grease the seal.

MAINTENANCE

FILTERS/CHECK VALVES

The check valves stop cross flow between the hot and cold supplies.

To clean the Check Valves.

Undo and remove the Check valve. Using a pair of pliers remove the Non return valve and filter. Wash the filter with clean running water, dry and lightly grease the seals.

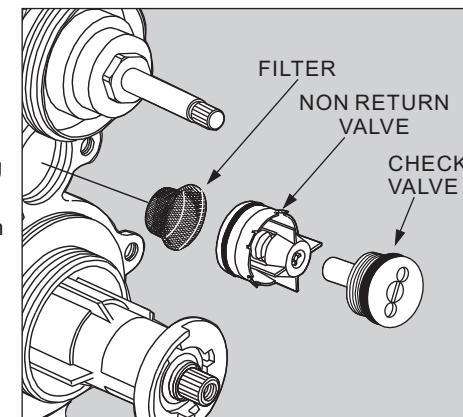

CARE OF YOUR SHOWER VALVE

We recommend cleaning the valve with a soft damp cloth.

We strongly advise against the use of ALL cleaning products.

TROUBLE SHOOTING

SYMPTOM	SOLUTION
After installation the shower runs HOT or COLD and will not mix.	Hot and cold supplies are plumbed the wrong way round. Remove the thermostatic cartridge, undo the clamp nut and pull the cartridge out (using the temperature control knob to aid removal). Reinstall it with the locating lug pointing away from the inlets.
Shower will not run hot enough when first installed.	Maximum temperature needs adjusting, see 'temperature setting'.
Cold water tracking through the valve into the hot water system.	Check and clean the check valve cartridges and filters located under the check valves.
Very low flow or no flow (gravity).	Check hot and cold feeds (the valve will shut down if either the hot or cold supply fails).