

BRISTAN

Installation Instructions and User Guide

Opac Mini Thermostatic
Surface Mounted Shower
Valve

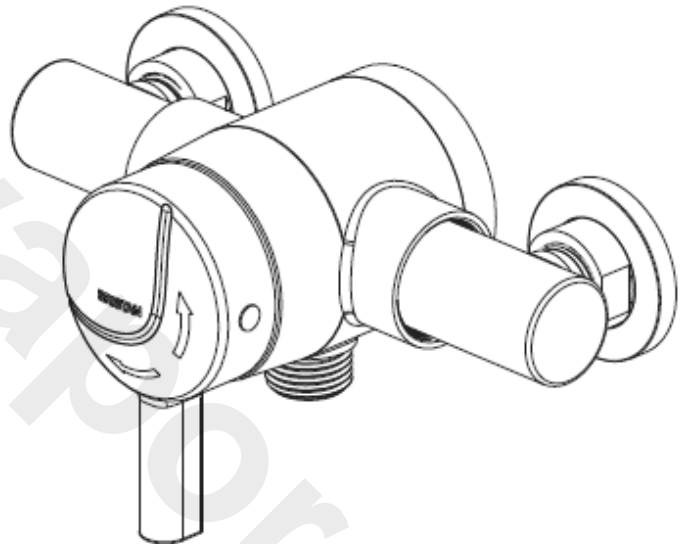

Models covered: MINI2 TS1203 EL C,
MINI2 TS1203 EH C & MINI2 TS1203 RR C

Please keep this booklet for future
Reference.



Installer, when you have read these
instructions please ensure you leave them
with the user.

Contents

Thank you for choosing Bristan, the UK's leading showers and taps expert. We have designed this product with your enjoyment in mind. To ensure that it works to its full potential, it needs to be fitted correctly. These fitting instructions have been created to give you all of the information you need and, if you need any further help, please do not hesitate to give us a call on 0330 026 6273.

Important Safety Information	3
General Information	4
Product Features	5
Specifications	6
Dimensions	7
Pack Contents	8
Installation Requirements	9-13
Flow Regulators	14-15
Prior to Installation	16
Installation	17-18
Operation	19
Commissioning	20
Maintenance	21-22
Map of Hard Water Regions in the UK	23
Troubleshooting	24-25
Guarantee	26-27

Important Safety Information

- Please read these instructions thoroughly and retain for future use.
- All products manufactured and supplied by Bristan are safe provided they are installed, used correctly and receive regular maintenance in accordance with these instructions.
- **If you are in any doubt about your ability to install this product safely you must employ the services of an experienced qualified plumber.**
- Remove all packaging and check the components for damage before starting installation.
-  **Warning:** Before starting any installation please consider the following: Prior to drilling into walls, check that there are no hidden electrical wires, cables or water supply pipes. This can be checked with the aid of an electronic detector.
If power tools are used do not forget to:
 - Wear eye protection
 - Unplug equipment after use
- The fitting of isolating valves is required as close as is practical to the supply inlet feeds of the thermostatic mixing valve.
-  **Warning:** Before installing the new shower valve it is essential that you thoroughly flush through the pipework in order to remove any remaining swarf, solder, etc. Failure to carry out this procedure could cause problems or damage to the workings of the shower valve.
- This product **must not** be modified in any way as this will invalidate the guarantee.

General Information

This product has been tested to comply with the BS EN 1287:1999 (LP) and BS EN 1111:1999 (HP) thermostatic mixing valve standards.

BS6700 recommends the temperature of stored water should never exceed 65°C. A stored water temperature of 60°C is considered sufficient to meet all normal requirements and will minimise the build up of lime scale in hard water areas (see Map of Hard Water Regions in the UK on page 23).

If the fitting is installed at low pressure (tank fed), then the minimum distance from the highest installed position of the showerhead to the underside of the cold tank should be at least 1 metre to ensure adequate performance.

Note: Nominally equal (balanced) inlet supply pressures are recommended for optimum performance with mixer showers.

This shower valve should be installed in compliance with the Water Supply (Water Fittings) Regulations 1999 and the Scottish Byelaws 2004.

If in doubt, contact a registered plumber or your Local Water Authority or the Secretary of The Institute of Plumbing, address as follows:-

The Institute of Plumbing,
64 Station Lane,
Hornchurch,
Essex, RM12 6NB
Tel: 01708 472791

Recommended Usage			
Domestic	✓	Heavy Commercial	✓
Light Commercial	✓	Health Care	✓

Specifications

Inlet Connections: 15mm compression, with adjustable centres.

Operating Pressure Range: Min: 0.1 bar – Max: 5.0 bar – Maximum recommended imbalance between hot and cold supply should not exceed a ratio of 5:1.

Maximum Static Pressure: 10.0 bar

Maximum Outlet Temperature: Factory pre-set to 41°C (can be re-set to suit site conditions).

Supply Requirements:

Minimum cold water supply temperature: 5°C.

Maximum cold water supply temperature: 25°C.

Maximum hot water supply temperature: 80°C.

(a maximum hot water supply temperature of 60 – 65°C is recommended for ablutionary purposes).

Note: The inlet hot water temperature must be at least 10°C above the required blend temperature (e.g. shower temperature 43°C: minimum hot supply 53°C).

Dimensions (mm's)

MINI2 TS1203 EL C

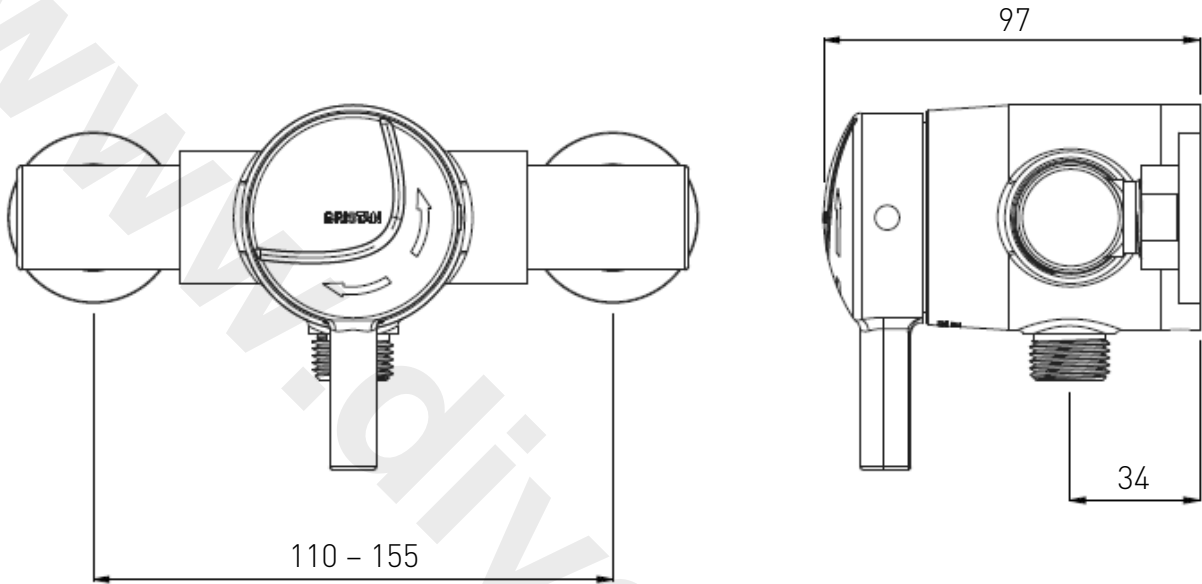

MINI2 TS1203 EH C

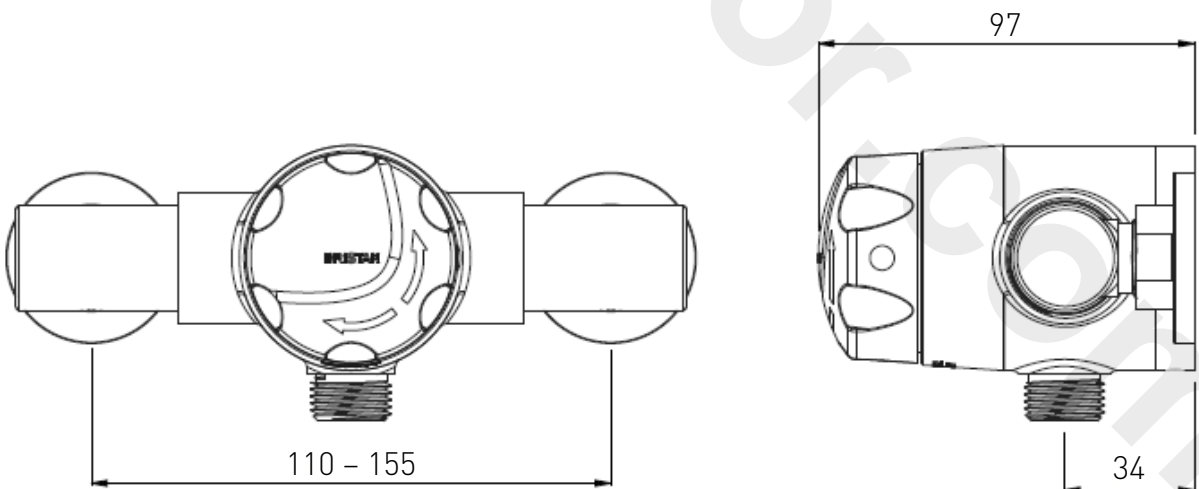

Dimensions (mm's)

MINI2 TS1203 EL C

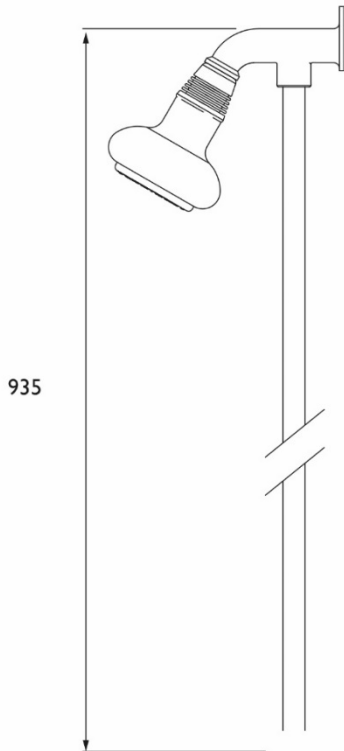
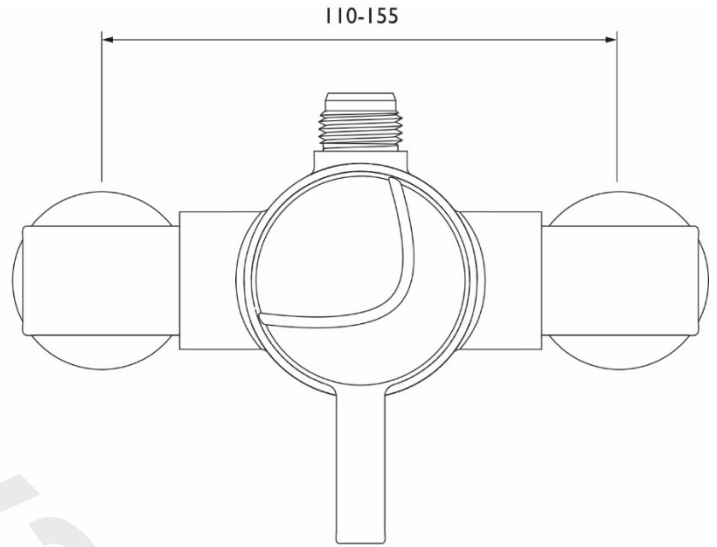
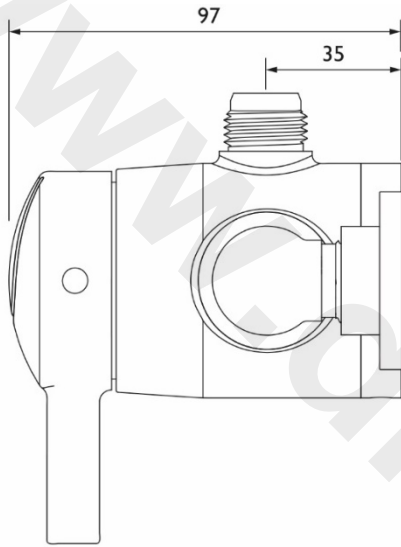

Pack Contents

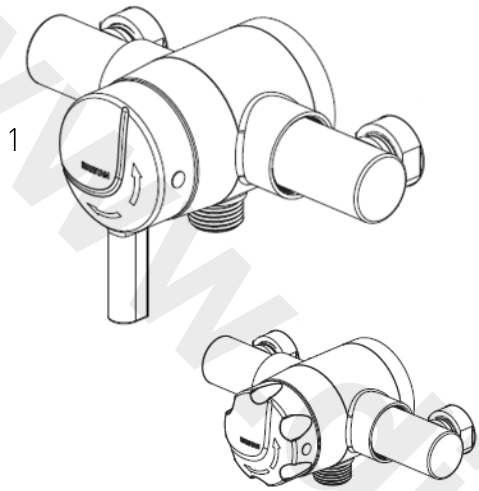

- 1 Shower Valve
- 2 Long elbows x2
- 3 Covers x2
- 4 Filters x2 (Pre-fitted)
- 5 Green flow regulator (Pre-fitted)
- 6 Yellow flow regulator (Pre-fitted)
- 7 Hexagonal key
- 8 Backplate fixings x2

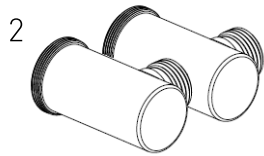

Pack Contents

- 1 Shower Valve
- 2 Long elbows x2
- 3 Shrouds x 2
- 4 Backplate Fixings
- 5 Riser Kit

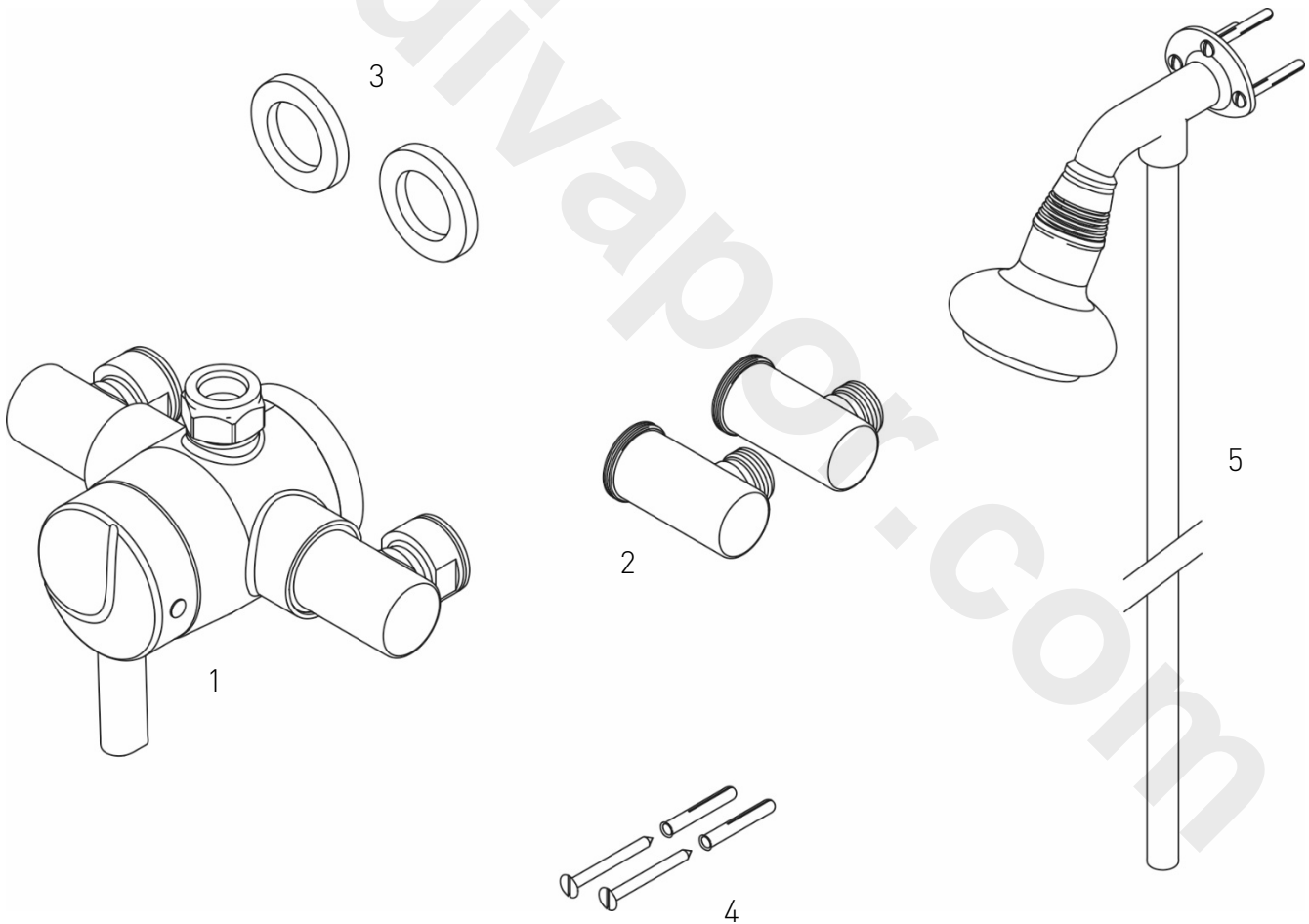

Installation Requirements

This shower valve must be installed in compliance with current water regulations. If you have any doubts about the water regulation requirements contact your local water services provider or use the services of a professional plumber.

This shower valve is suitable for use with the following water supply systems.

- Gravity Fed Hot and Cold (pressure Balanced)
- Gravity Fed Hot and Mains Cold (differential pressure – see Specification section on page 6.
- Instantaneous Water Heater (combination boiler)
- Unvented System
- Pumped System

Gravity Fed Hot and Cold

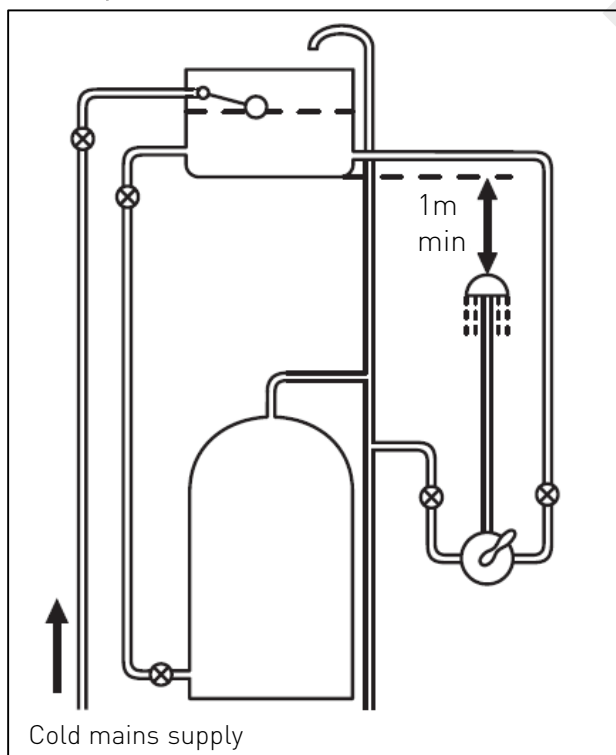

⚠ Important: If you install this shower valve with a gravity fed system, there must be a minimum head (vertical distance) from the underside of the cold water storage tank to the showerhead position of at least 1 metre.

Note: Pumped system (with Essex flange) If you install this shower valve to a pumped gravity fed system where the minimum head (vertical distance) from the underside of the cold water storage tank to the top of the hot water cylinder is less than 1 metre we recommend an Essex flange is used as shown on page 10.

Flushing Pipework

⚠ Important: Before connecting the shower valve (see Installation on pages 17-18), supply pipework **must** be flushed to clear debris before connecting the shower valve. Debris will reduce the performance and life of the shower.

Gravity Fed Hot and Mains Cold

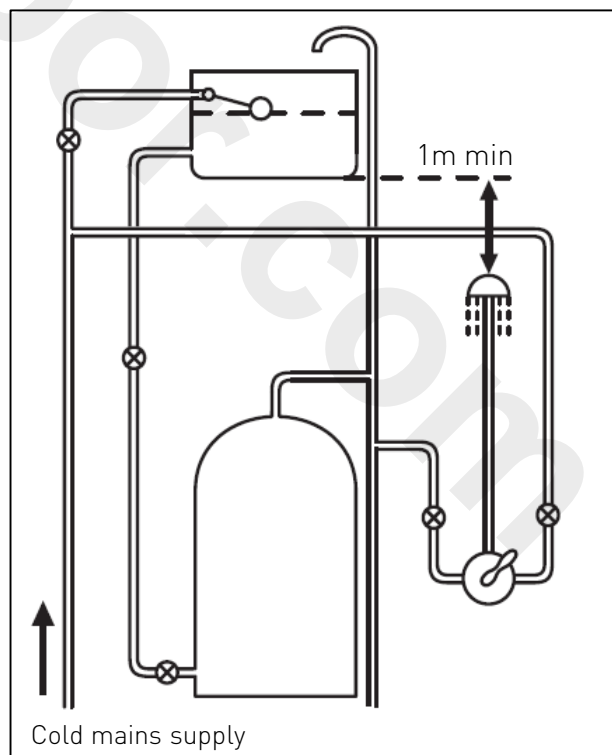

Installation Requirements

Instantaneous Water Heater

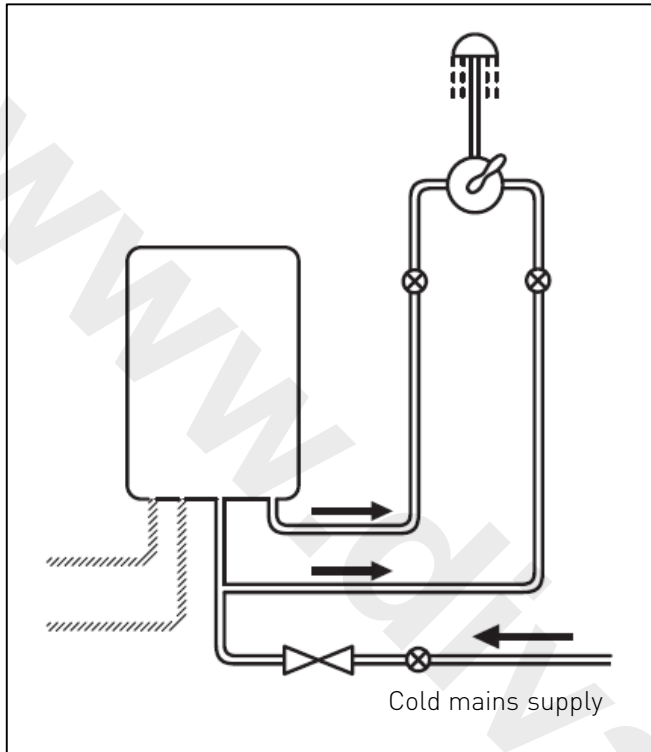

Unvented System

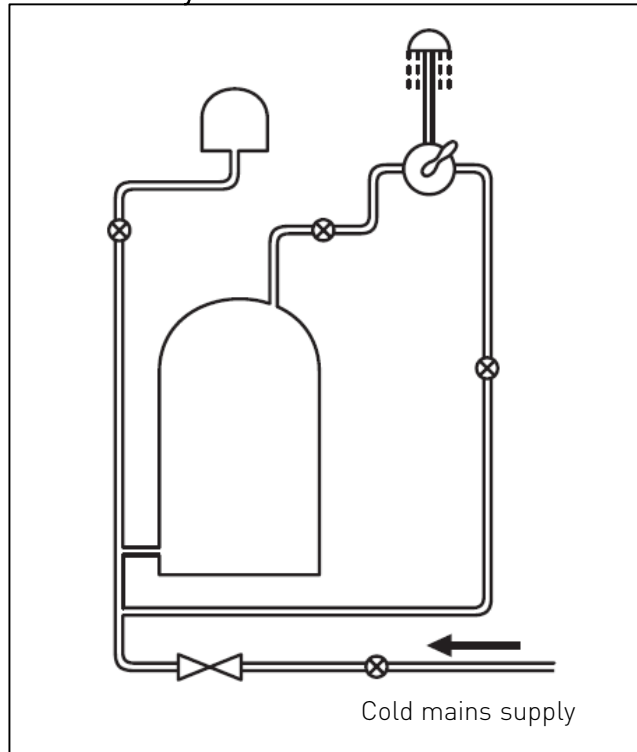

Pumped System

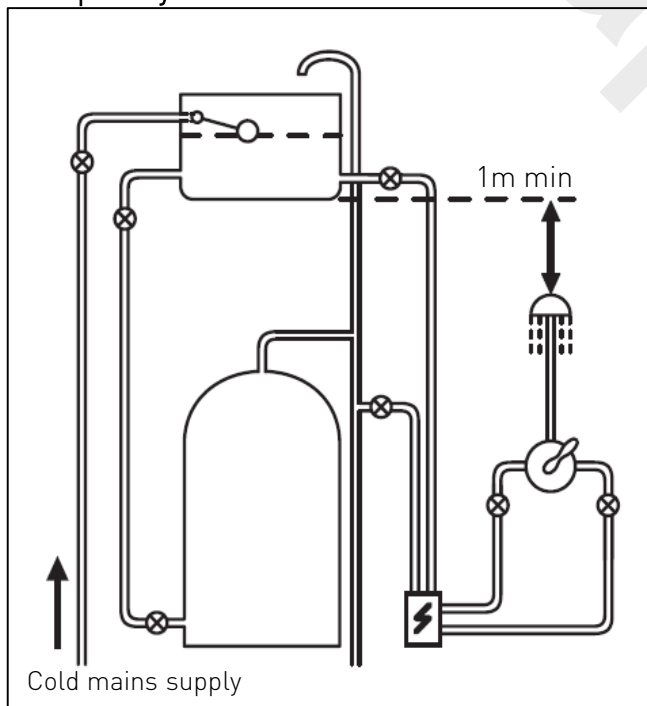

Pumped System (with Essex flange)

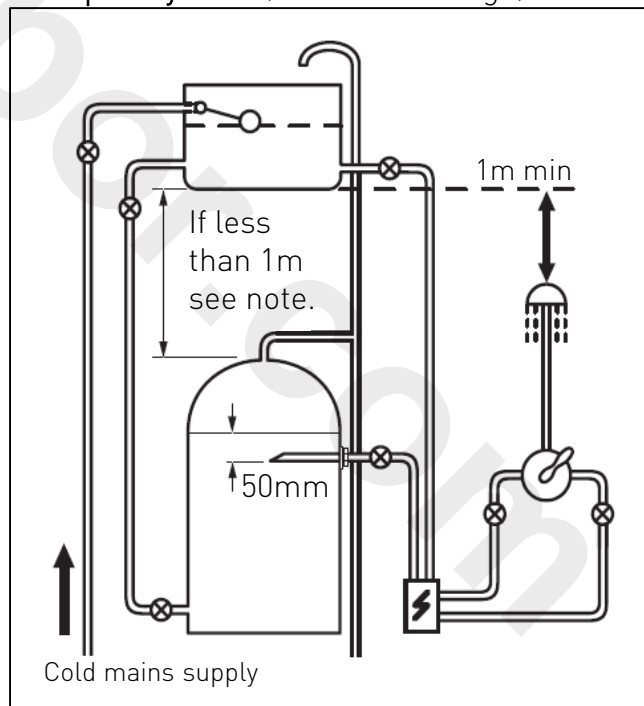

Key:  Isolating Valve  Reducing Valve  Shower Valve  Pump  Essex Flange

Installation Requirements

These fittings need to be installed in accordance with the following Installation Requirements and Notes (IRN) to ensure they meet the requirements of the Water Supply (Water Fittings) Regulations 1999 and the Scottish Byelaws 2004.

IRN R001: See text of entry for Installation Requirements or Notes.

IRN R040 - Schedule 2-15 (1): The fitting shall be installed so that its outlet discharges above the spill-over level of any fixed appliance as indicated below:-

For backflow protection in domestic or installations up to, and including, Fluid Category 3.

If the fitting cannot be installed as indicated in the table opposite it shall be installed as either **a** or **b** below:

a: with an approved double check valve assembly or some other no less effective backflow prevention device immediately upstream of the inlet.

b: so that it draws water by gravity only from a cistern, or cylinder having a permanently open vent pipe, and the distributing pipe supplies no other fitting (other than draining tap) at a lower level.

For backflow protection in premises or installations up to, and including Fluid Category 5.

The vertical distance of the outlet above the spill-over level shall be not less than 20mm or twice the diameter of the inlet pipe to the fitting, which ever is the greater. If the fitting cannot be installed as indicated it shall be installed with a backflow prevention arrangement suitable for the Fluid Category.

Size of tap or combination fitting.	Vertical distance of outlet above spill-over level.
1. Not exceeding 1/2 in	20mm
2. Exceeding 1/2 in but not exceeding 3/4 in	25mm
3. Exceeding 3/4 in	70mm

Installation Requirements

Conditions of use for Type 2 (Thermostatic mixer) valves

	High Pressure	Low Pressure
Maximum Static Pressure (Bar)	10	10
Flow Pressure, Hot & Cold (Bar)	0.5 to 5	0.1 to 1.0
Hot Supply Temperature (°C)	55 to 65	55 to 65
Cold Supply Temperature (°C)	Equal to or less than 25	Equal to or less than 25

Note: Valves operating outside these conditions cannot be guaranteed by the Scheme to operate as Type 2 valves.

If a water supply is fed by gravity then the supply pressure should be verified to ensure the conditions of use are appropriate for the valve.

Recommended Outlet temperatures

We recommend the following set maximum mixed water outlet temperatures for use in all premises:

41°C for showers;

The mixed water temperatures must never exceed 46°C.

The maximum mixed water temperature can be 2°C above the recommended maximum set outlet temperatures.

Note: 46°C is the maximum mixed water temperature from the bath tap. The maximum temperature takes account of the allowable temperature tolerances inherent in thermostatic mixing valves and temperature losses in metal baths.

 **Warning:** It is not a safe bathing temperature for adults or children.

The British Burns Association recommends 37 to 37.5°C as a comfortable bathing temperature for children. In premises covered by the Care Standards Act 2000, the maximum mixed water outlet temperature is 43°C.

The thermostatic mixing valve (TMV) will be installed in such a position that maintenance of the TMV and its valves and the commissioning and testing of the TMV can be undertaken.

The fitting of isolation valves is required as close as is practical to the water supply inlets of the thermostatic mixing valve.

Installation Requirements

Conditions of use for Type 3 (Thermostatic mixer) valves

In order to give compliance with N.H.S. specification D08 the table below lists the conditions for normal use. These valves will perform adequately outside these parameters, however they cannot be guaranteed by the scheme to operate as Type 3 valves. If they are required to work with other supply conditions an engineer must carry out a risk assessment and satisfy themselves that the valves are suitable for use.

Normal Conditions of Use for Type 3 valves

	High Pressure	Low Pressure
Maximum Static Pressure (Bar)	10	10
Flow Pressure, Hot & Cold (Bar)	1.0 to 5.0	0.2 to 1.0
Hot Supply Temperature (°C)	55 to 65	55 to 65
Cold Supply Temperature (°C)	5-20	5-20
Minimum Temperature Differential °C	10°C	10°C

This valve has been approved for use in the following designations.

Code	Operating Pressure	Application
HP - SE	High Pressure	Shower
LP - S	Low Pressure	Shower

Key:

HP - High Pressure LP - Low Pressure

The TMV scheme recommends the following set maximum mixed water outlet temperatures for use in all premises:

41°C for showers;

The mixed water temperatures must never exceed 46°C.

The maximum mixed water temperature can be 2°C above the recommended maximum set outlet temperatures.

Note: For wash basins, washing under running water is assumed.

Flow Regulators

Selecting Flow Regulators

Supply System		Flow Regulator		
Cold Supply	Hot Supply	Cold	Hot	Comments
0.1 to 1.0bar	0.1 to 1.0bar	No	No	Maximum pressure loss ratio 5:1
1 to 5 bar or pumped	1 to 5 bar or pumped	Green (7 litre)	Yellow (5 litre)	◆ Use arrangement for pumped system
Mains 1.0 – 10 bar	Gravity 0.1 to 0.5 bar	Green (7 litre)	No	
	Gravity Above 0.5 bar	Green (7 litre)	Yellow (5 litre)	
	Unvented Mains / Mains Pressurised			
	Instantaneous Water Gas Heater	Green (7 litre)	* Yellow (5 litre)	
	**Instantaneous Water Electric Heater	Yellow (5 litre)	No	
	Any vented (open outlet) Heater Gas / Electric, e.g. Electric Shower	Do not use with a mixer valve – This would be extremely dangerous		

Flow Regulators

◆ Regulators can be fitted if water economy is required.

* Yellow (5 litre) regulator may not be necessary on some gas water heaters.

** ⚠ **Important:** It is a requirement of Instantaneous Electric Heaters that a stable flow of water passes through the heater. This requirement can be satisfied by using a 'flow stabiliser' fitted prior to the heater and should be adjusted to give a temperature of between 45 – 50°C from the heater.

Flow regulators are factory fitted.

Study the table on the previous page and decide which flow regulators are required for your particular situation.

Unscrew both inlet elbows from the valve body and remove flow regulator/s using long nose pliers from the non return valve retainer.

Screw inlet elbows back into the valve body.

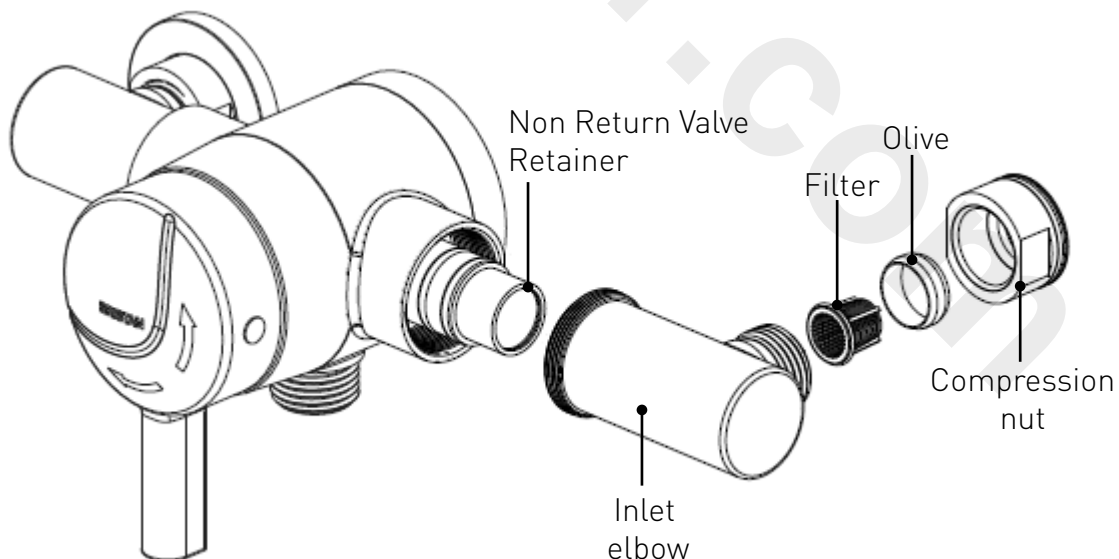
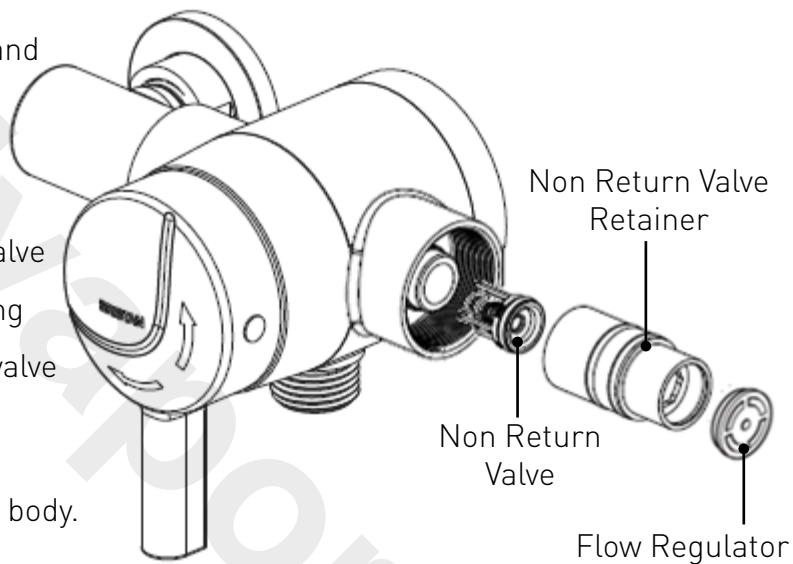

Prior to Installation

This shower valve is supplied with two small and two large elbows to give varying centres.

Note: The shower valve is supplied with the small elbows fitted.

Choose elbow configuration to suit Inlet centres

2 x small elbows – 110-130 centres

2 x large elbows – 136-155

1 small elbow / 1 large elbow – 125-145

All measurements are in millimetres.

To remove the elbows

To remove the elbows from the body unscrew anti-clockwise.

To fit large elbows

Screw the large elbows clockwise into the valve body.

Important: The elbows must have at least two complete turns in the valve body.

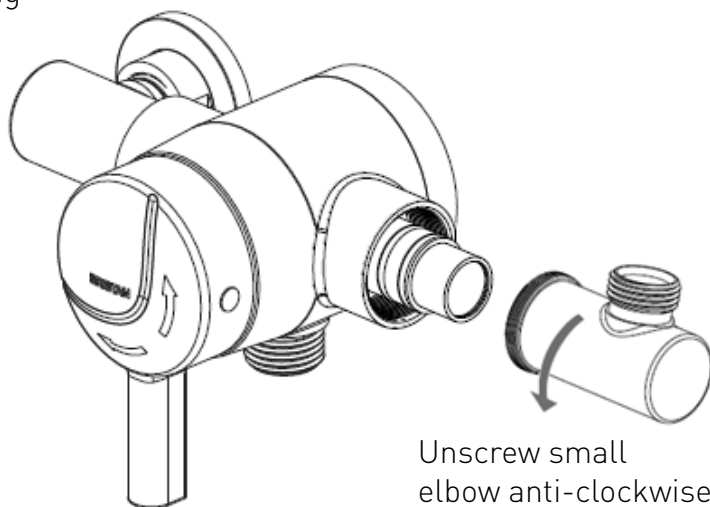

Unscrew small elbow anti-clockwise

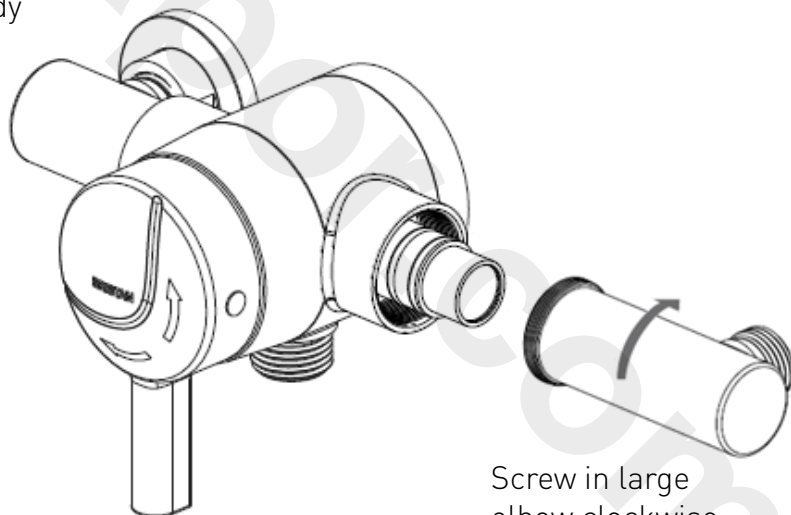

Screw in large elbow clockwise

Installation

Before Installation

Flush through the pipework to ensure removal of debris. Turn off the mains water supply and close any isolating valves.

1. Inlet positions

The shower valve has three inlet positions – top, bottom and rear. Rotate the inlet elbows as required.

With the elbows screwed fully against the valve body it can be unscrewed a maximum of 1.5 turns to allow for lateral tolerance.

Sufficient 15mm diameter supply pipes should protrude through the finished wall surface to fit fully into the shower valve elbows.

2. Attach backplate to wall

Loosen the 'backplate' grub screw on the back of the valve using the hexagonal key. Use the backplate as a template and mark the centres of the fixing holes onto the wall.

 **Warning:** Please check for any hidden pipes and cables before drilling holes in the wall.

Drill suitable holes and insert the wall plugs. Securely attach the backplate to the wall using the screws provided.

Important: Water supplies to the mixer must be with hot on the left and cold on the right when viewed from the front.

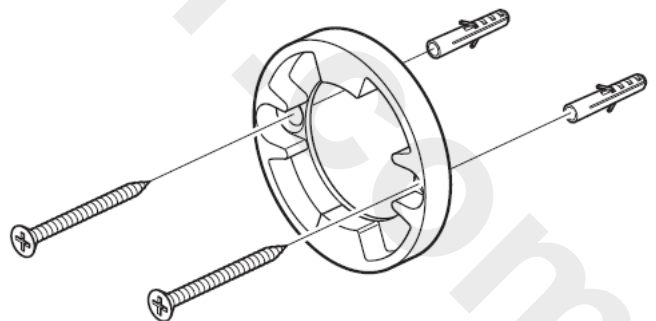
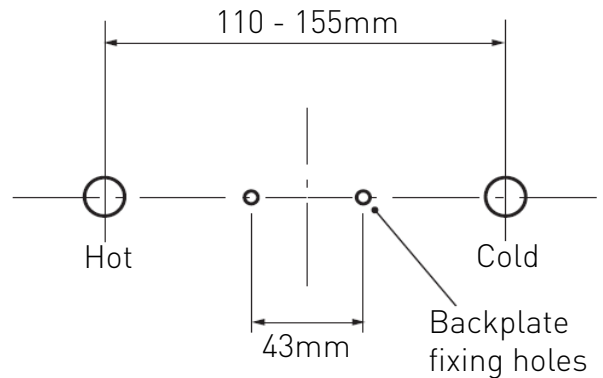

Installation cont.

3. Attach shower valve

Place the shrouds over the water supply pipes. Insert the 15mm hot and cold water supply pipes into the inlet connections and tighten the nuts. Ensure the olives and filters are in place.

Secure the shower valve to the backplate by tightening the backplate grub screw.

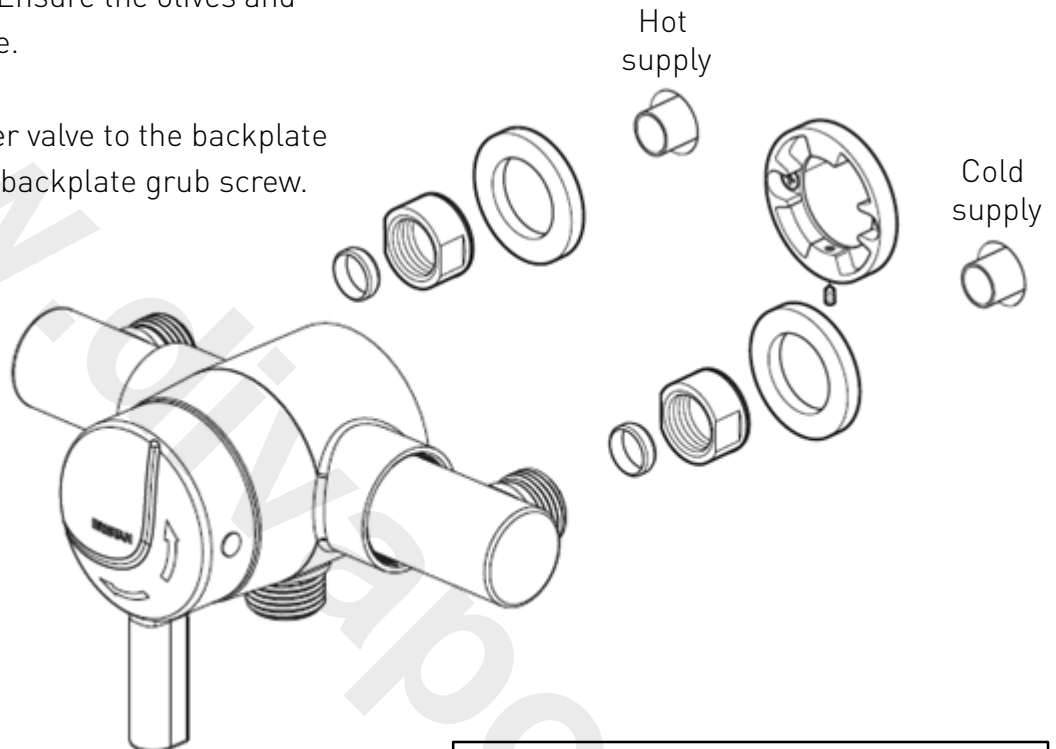

Note: The shower valve inlet positions are shown at the rear as an example.

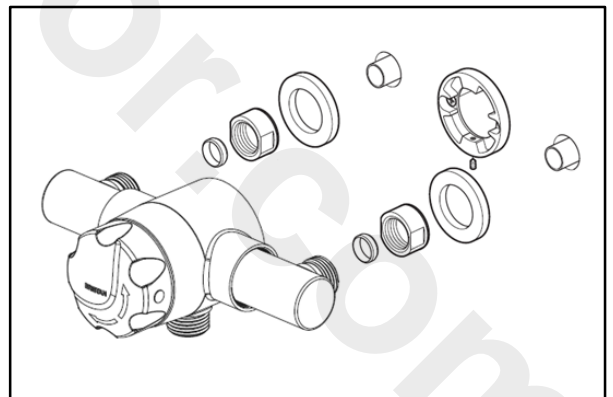

Operation

On/Off and Temperature Control

Turn the lever anti-clockwise to turn on and increase temperature.

Turn the lever clockwise to decrease temperature and turn off.

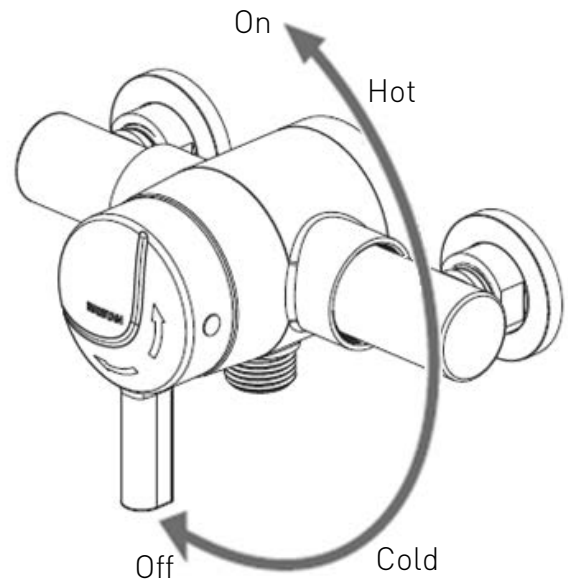

Commissioning

Commissioning notes for Thermostatic Mixing Valves

The first step in commissioning a thermostatic mixing valve is to check the following:

1. The designation of the thermostatic mixing valve matches the intended application.
2. The supply pressures are within the valves operating range.
3. The supply temperatures are within the valves operating range.
4. Isolating valves (and strainers preferred) are provided.

If all these conditions are met, proceed to set the temperature as stipulated in the maintenance section.

The mixed water temperature at the terminal fitting must never exceed 46°C.

It is a requirement that all approved valves shall be verified against the original set temperature results once a year. When commissioning / testing is due the following performance checks shall be carried out:

- Measure the mixed water temperature at the outlet.
- Carry out the cold water supply isolation test by isolating the cold water supply to the TMV wait for five seconds, if water is still flowing check that the temperature is below 46°C.

If there is no significant change to the set outlet temperature ($\pm 2^{\circ}\text{C}$ or less change from the original settings) and the fail-safe shut off is functioning, then the valve is working correctly and no further service work is required.

Notes: If there is a residual flow during the commissioning or the annual verification (cold water supply isolation test), then this is acceptable providing the temperature of the water seeping from the valve is no more than 2°C above the designated maximum mixed water outlet temperature setting of the valve.

Temperature readings should be taken at the normal flow rate after allowing for the system to stabilise.

The sensing part of the thermometer probe must be fully submerged in the water that is to be tested.

Any TMV that has been adjusted or serviced must be re-commissioned and re-tested in accordance with the instructions in the maintenance section.

The installation of thermostatic mixing valves must comply with the requirements of the Water Supply (Water Fittings) Regulations 1999.

Maintenance

General Cleaning

Your fitting has a high quality finish and should be treated with care to preserve the visible surfaces. All surfaces will wear if not cleaned correctly. The only safe way to clean your mixer is to wipe with a soft damp cloth. Stains can be removed using washing up liquid. All bath cleaning powders and liquids will damage the surface of your fitting, even the non-scratch cleaners.

Note: Never use abrasive detergents or disinfectants or those containing alcohol, hydrochloric acid or phosphoric acid.

Cartridge Maintenance

We advise that the shower valve is regularly serviced in hard water areas to maintain the flow of water (see map of Hard Water Regions in the UK on page 23).

Isolate both hot and cold water supplies to the shower valve by either:

- Turning the water supply off at the mains stopcock or

- Turning off the isolation valves to the shower valve

1. Remove the lever: remove the plastic cap, loosen the grub screw using the hexagonal key and carefully pull the lever off.

2. Unscrew the cartridge anti-clockwise (using a suitable spanner) and remove from the valve body.

3. Carefully remove the cartridge assembly and spring. Remove all visible 'O' rings and washers from the body.

4. Place the cartridge in a bowl and carefully add hot water (just off the boil) and vinegar to de-scale the cartridge. Leave in the solution until the water has cooled and rinse with clean water.

5. Replace all seals and grease with a silicon grease supplied by Bristan (part number: SP-495-0002) and carefully refit.

6. Reset the maximum temperature and refit the handle and cover.

Maintenance cont.

Adjusting the Temperature

The shower valve has been factory set with equal (balanced) hot and cold water supply pressures with the hot water supply at 65°C.

If your operating conditions are different from those above, the outlet water temperature may differ from the factory setting.

If required the shower valve can be re-calibrated to suit your own temperature requirements.

Set the temperature control lever to maximum and check the temperature of the water with a thermometer. If the temperature is not correct, re-calibrate the shower valve.

1. Turn the lever anti-clockwise to the maximum temperature position.
2. Remove the lever: remove the plastic

cap, loosen the grub screw using the hexagonal key and carefully pull the lever off.

3. Using the hexagonal key, turn the temperature adjusting screw to alter the temperature.

- Turn clockwise for a cooler temperature
- Turn anti-clockwise for a warmer temperature

Note: This will be the maximum temperature setting, it is recommended that the temperature is set no higher than 43°C.

4. Once the correct temperature is achieved, re-attach the lever and close the valve. Ensure the stop on the lever is in the correct position (vertically down), allowing the valve to turn on anti-clockwise.

5. Tighten the grub screw to lock the lever in place and push fit the plastic cap.

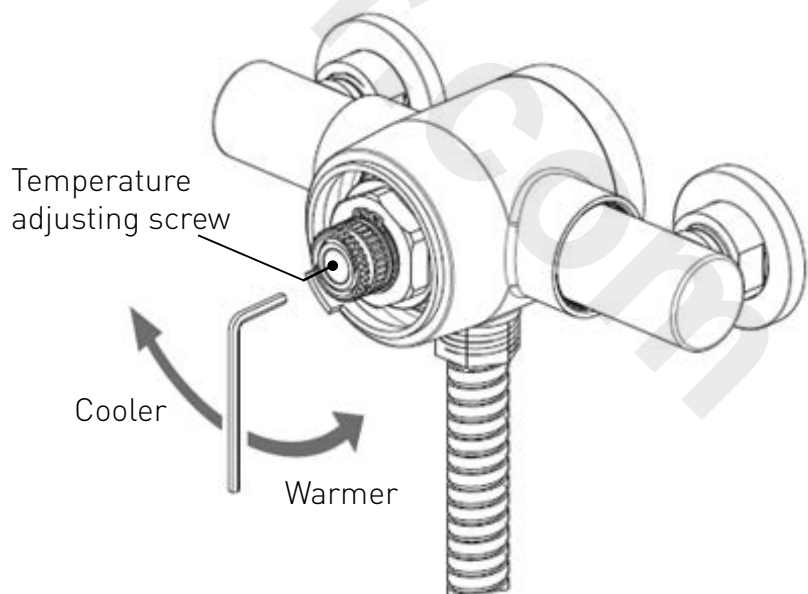
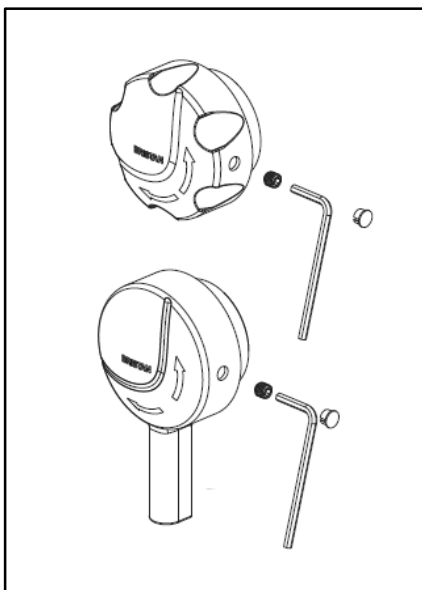

Troubleshooting

Symptom	Cause	Remedy
No flow or low flow rate and / or varying temperatures.	Check filters for any blockage.	Clean as necessary, refer to Maintenance section (pages 21-22).
	Partially closed stop or service valve in water supply pipework to the shower valve.	Open stop or service valve.
	Instantaneous water heater cycles on and off as the flow rate or pressure is too low.	Increase water flow rate or pressure through system. Contact the boiler Manufacturer.
	Head of water is below the minimum distance required.	Raise the cistern or fit a shower booster pump.
	Inlet filter is partially blocked.	Clean or replace, flush through pipework before refitting.
	Hot or cold water is being drawn off elsewhere causing pressure changes or instantaneous boiler temperature changes.	Do not use other water outlets when using the shower.
	Make sure the maintained inlet pressures are nominally balanced and sufficient.	Refer to Installation Requirements section (pages 9-13).
	Airlock or potential blockage of the pipework.	Flush through pipework to ensure removal of debris and any airlocks.
	No hot or cold water reaching the shower valve.	Check hot and cold feeds (the valve will shut down if either the hot or cold supply fails).
Water leaking from showerhead.	This is normal for a short time after turning off.	Adjust the angle of showerhead in holder as necessary to vary draining time.
	Shower control valve failing to close fully, possibly due to water borne debris.	Remove shower control valve assembly and check. Refer to Maintenance section (pages 21-22). Before dismantling shower valve.
	Flow control valve seals damaged.	Check condition of flow control valve and replace as necessary.

Troubleshooting

Symptom	Cause	Remedy
Maximum water temperature too hot or cold.	Maximum water temperature set incorrectly.	Reset maximum water temperature. Refer to 'Maximum Temperature Setting' in Commissioning section (page 20) and Adjusting the Temperature in Maintenance section (page 22).
Outlet water temperature too hot / cold.	Inlet filter partially blocked.	Check insert filters for any blockages and clean as necessary.
	Installation conditions outside operating parameters.	Refer to Installation Requirements section (pages 9-13). Service shower valve as recommended. Refer to maintenance section (page 21-22). Refer to Adjusting the Temperature section (page 22).
Water temperature too cold – maximum water temperature incorrectly set.	Hot water temperature is less than 10°C above the required blend temperature.	Adjust hot water temperature or wait for water to reheat if stored system is used.
	Instantaneous water heater not igniting because water flow rate is too low.	Increase water flow through the system. Check cartridge inlet filters and clean or replace. Refer to Maintenance section (pages 21-22). Contact the boiler manufacturer.
	Instantaneous water heater not igniting because the water pressure is too low.	Increase water pressure through system. Contact the boiler manufacturer.
Only hot or cold water from shower valve outlet.	Inlet water supplies are reversed (hot to cold supply).	Check the connections are the correct way round. Hot on the left and cold on the right when viewed from the front. Rework pipework as necessary.
	Inlet filter is partially blocked.	Clean or replace, flush through pipework before refitting.

www.divapor.com

www.divapor.com

Part Number: FI MINI2 1203 EL / EH C / RR C
Issue: D2

BRISTAN

Bristan Group Ltd.
Birch Coppice Business Park
Dordon
Tamworth
Staffordshire
B78 1SG
Web: www.bristan.com
Email: enquire@bristan.com

A Masco Company