

This product should only be fitted by a qualified plumber to NVQ (National Vocational Qualification) or SNVQ (Scottish National Vocational Qualification) Level 3. Should the installation be completed by a non-qualified person then the guarantee may be considered invalid.

For a claim made under our warranty written certification of your installers credentials can be required. For further information or to find a qualified installer in your area please visit the Institute of Plumbers website - www.iphe.org.uk

THE QUALIFICATIONS

At present, to be a plumber you need to follow the National Vocational Qualification (NVQ) route (Scottish National Vocational Qualification - SNVQ - in Scotland). These qualifications are made up of theory and practical work in the classroom/purpose built training facility and work based experience with a working plumber. Colleges should help students find a work placement, although many students organise it themselves.

The S/NVQ qualification works in levels. All recently qualified plumbers should hold S/NVQ Level 2 as basic with Level 3 as the preferred level. Level 2 will give you the foundation you need for a career in plumbing and teach you domestic plumbing to a satisfactory level. Level 3 is more comprehensive and deals with domestic, commercial and industrial plumbing along with aspects such as gas - if you want to one day set up your own business, this is the level to reach. The Institute of Plumbing and Heating Engineering, and the industry as a whole recommends that all plumbers reach a minimum of Level 3.

Reaching Level 3 has other advantages. The Institute runs a Master Plumber Certificate, which only those attaining Level 3 or equivalent can reach as long as they have the relevant experience as well. Those with S/NVQ Level 3 can (once in membership with the Institute for five years as a Member MIPHE) gain Engineering Technician EngTech status with the Engineering Council (UK).

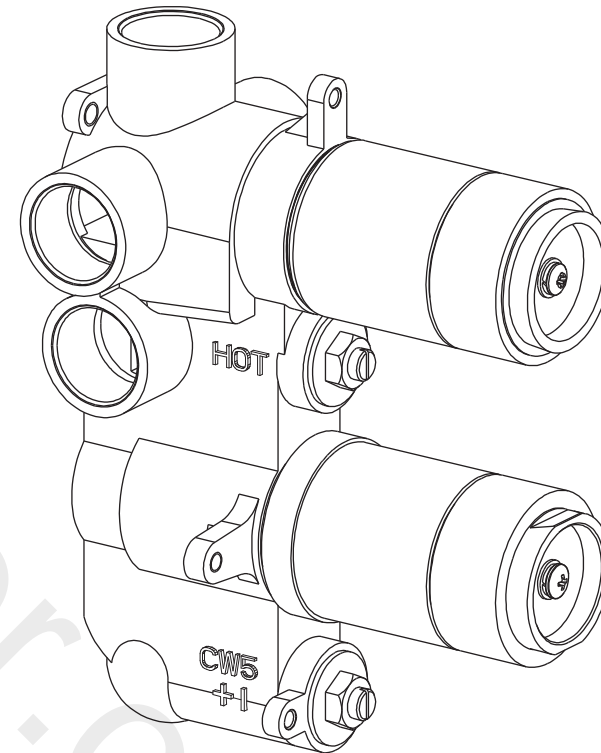

For any further information please contact Crosswater on: **0845 873 8840**

Or visit our web-site at www.crosswater.co.uk

The manufacturer reserves the right to make technical modifications without prior notice.

INSTALLATION INSTRUCTIONS

INTRODUCTION

This thermostatic valve is suitable for use with all water systems with a operating pressure of 3.0-5.0 bar and static pressure of 10 bar.(beyond which pressure reducing valves must be fitted).

The thermostatic valve has three outlets, two that can be controlled simultaneously.

The two open outlets allow for additional fittings (eg Body jets, hand shower) to benefit from thermostatically controlled supply. Any such outlets must have a stopcock/flow control. Blank off and seal the open outlet if not required.

PARTS IDENTIFICATION

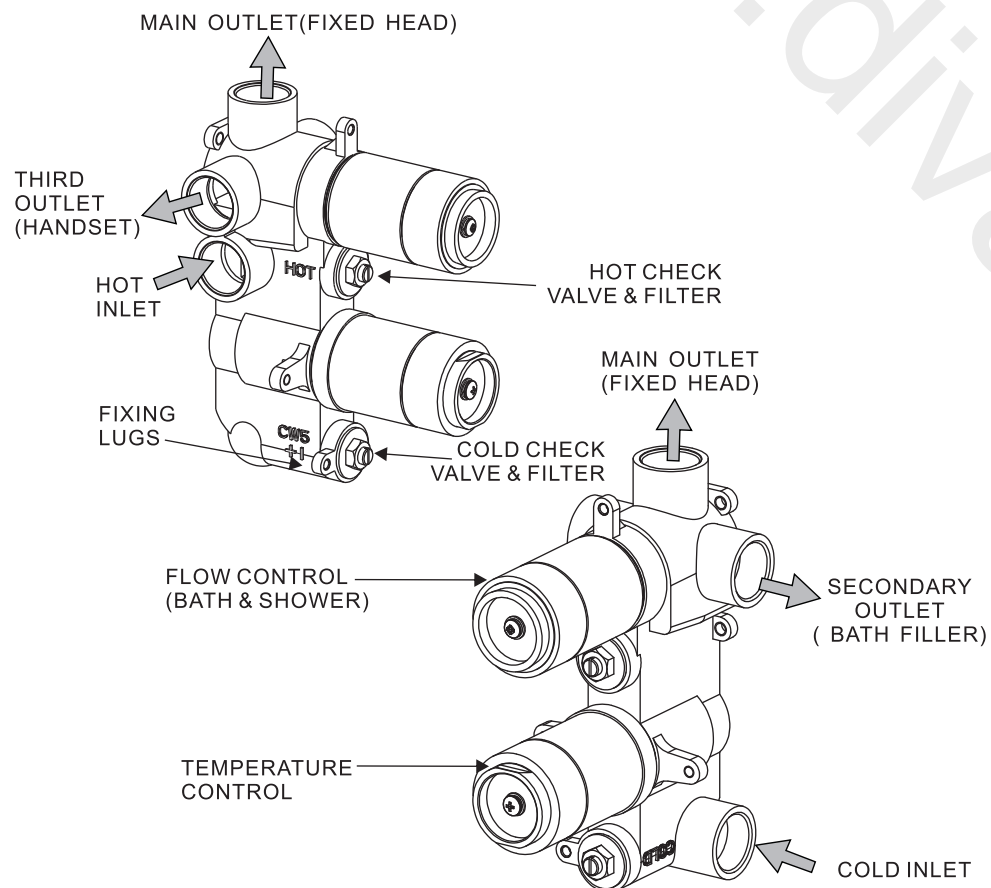

NOTE: FOR ILLUSTRATIVE PURPOSES HANDLES ARE NOT SHOWN

DIMENSIONS

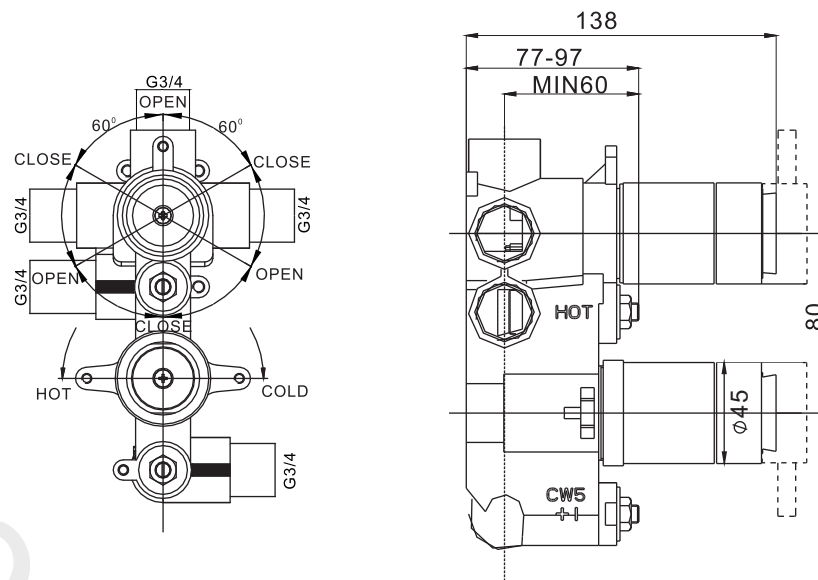

TMV APPROVED INSTALLATIONS

Where valves are required to be installed in accordance with TMV2 or TMV3 requirements please install them strictly in accordance with the separate Instruction Manual supplied with this unit.

NOTE: ALL DIMENSIONS IN MILLIMETRES

INSTALLATION

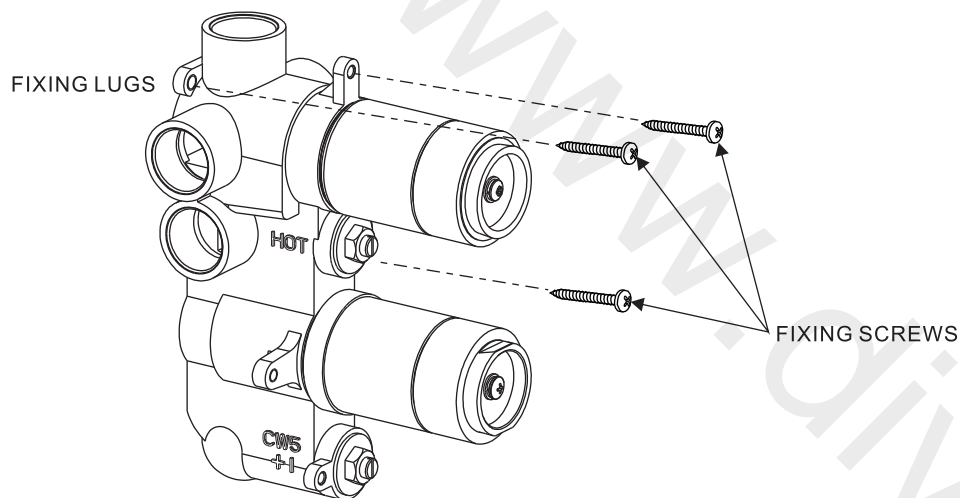

NB. Cover plate shown for illustration purposes only. It is supplied separately various styles available.

FIG. 1 FITTING PLASTIC DUST COVER

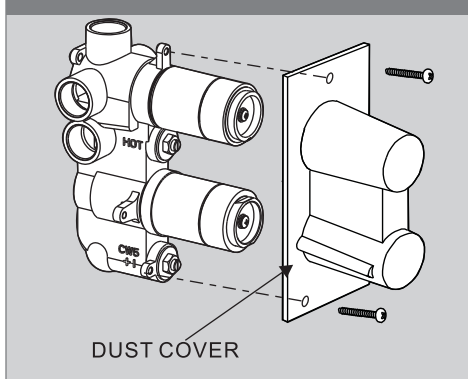
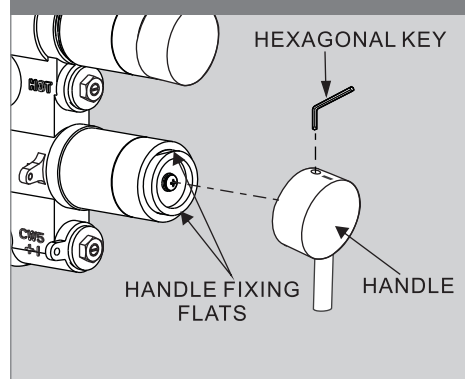

FIG. 2 FITTING CONTROL HANDLES



INSTALLATION

NOTES:

Please read these instructions carefully and keep in a safe place for future reference. The installation must comply with all Local/National Water Supply Authority Regulations/Bye laws and Building and Plumbing Regulations (UK: BS6700). This valve is a mixing device and therefore requires the water supplies to be reasonably balanced, otherwise we recommend a pressure reducing valve to be fitted.

The valve is fitted with integral WRC approved single check valves cartridges which command the water supply, therefore the thermostatic valve is protected against cross-flow due to unbalanced line pressures as required by the Water Supply (Water Fittings) Regulations 1999.

Fitting isolating valves to the inlet feeds is recommended for ease of maintenance.

INSTALLATION

Remember to turn off the mains water supply before connecting to any existing pipe work.

Warning! Please check for any hidden pipes and cables before drilling holes in the wall.

Position the valve onto the wall and mark the position of the fixing lugs (x3). Make sure the valve is set back from the front face of the wall by the appropriate depth to allow for plasterboard, filling and tiling etc. (min. 78mm to max. 105mm see dimension page).

Mount casting to the wall using suitable fixings.

Always leave access to the four front cartridges for servicing.

Once the valve has been secured to the wall, the black Plastic Dust Cover can be temporarily attached to the valve with the screws supplied. This will protect the valve while the rest of the work is completed (**see fig 1**).



Do not use tapered threaded adaptors or excessive thickness of sealing tape as this may damage the valve body and result in a concealed leak within the wall cavity.

Blank off and seal the open outlet if it is not required.

Remove the Plastic Dust Cover.



Turn on supplies and test all connections for water tightness.

Remove Hot and Cold check valves, and flush out the installation, clean the filters and refit.

Apply a narrow bead of clear silicone sealant around the back edge of the cover plate and carefully press into position.

Fit the control knobs by lining up the flat surface of the valve cover with the grub screw on the handle, tighten the screw with the supplied hexagonal key (**see fig 2**).

TEMPERATURE SETTING

To set the temperature, remove the handle and unscrew the centre screw of the thermostatic control cover. Rotate the exposed thermostatic spindle (clockwise for cold, and anti-clockwise for hot) until the maximum desired showering temperature is set (42°C-suggested maximum "pre-set" temperature). Then line up the screw head on the back of the thermostatic control cover with the stop on the cartridge. Push the control cover onto the splines and tighten the centre screw, refit the handle. The thermostat is now set to its new temperature and can only be increased or decreased by repeating this process.

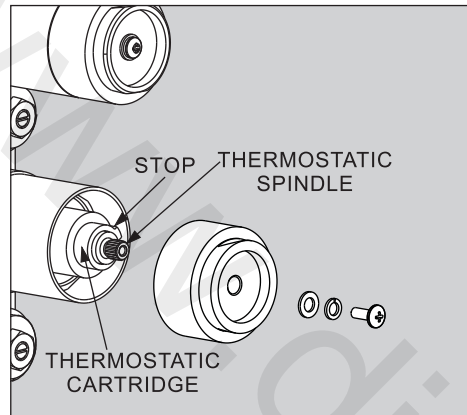

MAINTENANCE

Note: To avoid damage, please remove all chrome parts before any maintenance takes place.

THERMOSTATIC CARTRIDGES

The 1" concealed thermostatic valve should give trouble free service, but in the event of failure, servicing is straight forward.

To remove the thermostatic cartridge.

Undo the cartridge clamp nut (take note of the orientation of the cartridge) and pull the cartridge out using the temperature control knob to aid removal. Wash the cartridge with clean running water and make sure that any trapped debris has been removed. Dry and lightly grease the seals (only use silicone grease) and replace the cartridge making sure that as before the recess on the body of the valve is aligned with the slot in the raised central section of the plastic cartridge. This is to make sure the lug on the shroud is in the required 2 o'clock position as shown.

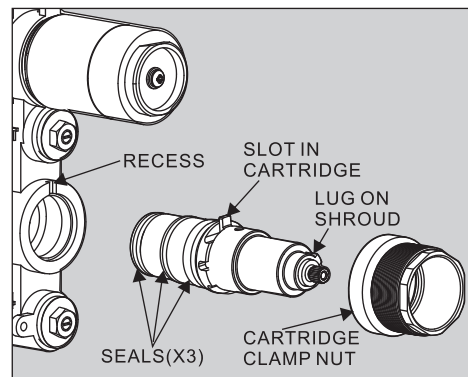

FLOW CONTROL CARTRIDGE

The Flow Control Cartridge uses ceramic discs which normally last indefinitely unless debris manages to get between them. Wash the cartridge with clean running water, dry and lightly grease the seal.

MAINTENANCE

FILTERS/CHECK VALVES

The check valves stop cross flow between the hot and cold supplies.

To clean the Check Valves.

Undo and remove the Check valve. Using a pair of pliers remove the Non return valve and filter. Wash the filter with clean running water, dry and lightly grease the seals.

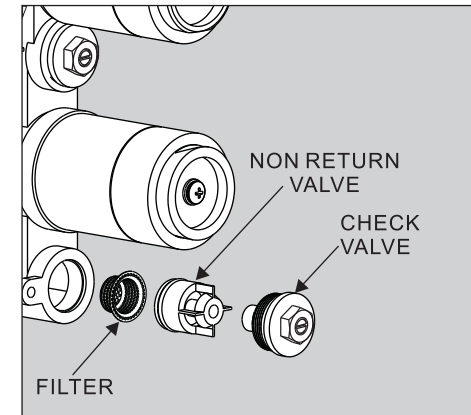

CARE OF YOUR SHOWER VALVE

We recommend cleaning the valve with a soft damp cloth. We strongly advise against the use of ALL cleaning products.

TROUBLE SHOOTING

SYMPTOM	SOLUTION
After installation the shower runs HOT or COLD and will not mix.	Hot and cold supplies are plumbed the wrong way round. The hot and cold supplies need to be redone to the correct inlets as marked and described in the installation instruction.
Shower will not run hot enough when first installed.	Maximum temperature needs adjusting, see 'temperature setting'.
Cold water tracking through the valve into the hot water system.	Check and clean the check valve cartridges and filters located under the check valves.
Very low flow or no flow (gravity).	Check hot and cold feeds (the valve will shut down if either the hot or cold supply fails).