

This product should only be fitted by a qualified plumber to NVQ (National Vocational Qualification) or SNVQ (Scottish National Vocational Qualification) Level 3. Should the installation be completed by a non-qualified person then the guarantee may be considered invalid.

For a claim made under our warranty written certification of your installers credentials can be required. For further information or to find a qualified installer in your area please visit the Institute of Plumbers website - [www.iphe.org.uk](http://www.iphe.org.uk)

### THE QUALIFICATIONS

At present, to be a plumber you need to follow the National Vocational Qualification (NVQ) route (Scottish National Vocational Qualification - SNVQ - in Scotland). These qualifications are made up of theory and practical work in the classroom/purpose built training facility and work based experience with a working plumber. Colleges should help students find a work placement, although many students organise it themselves.

The S/NVQ qualification works in levels. All recently qualified plumbers should hold S/NVQ Level 2 as basic with Level 3 as the preferred level. Level 2 will give you the foundation you need for a career in plumbing and teach you domestic plumbing to a satisfactory level. Level 3 is more comprehensive and deals with domestic, commercial and industrial plumbing along with aspects such as gas - if you want to one day set up your own business, this is the level to reach. The Institute of Plumbing and Heating Engineering, and the industry as a whole recommends that all plumbers reach a minimum of Level 3.

Reaching Level 3 has other advantages. The Institute runs a Master Plumber Certificate, which only those attaining Level 3 or equivalent can reach as long as they have the relevant experience as well. Those with S/NVQ Level 3 can (once in membership with the Institute for five years as a Member MIPHE) gain Engineering Technician EngTech status with the Engineering Council (UK).

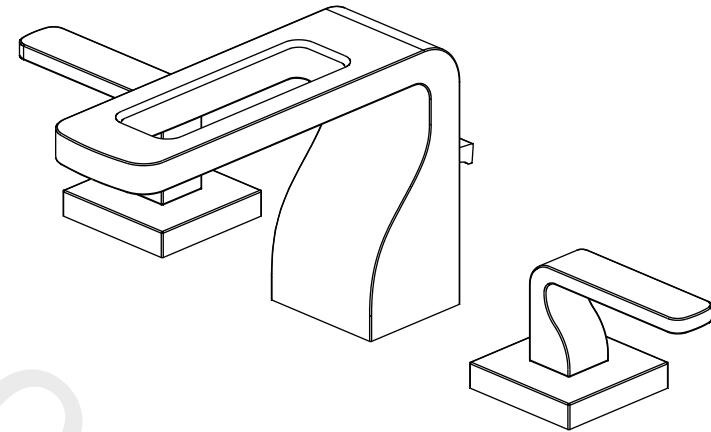

For any further information please contact Crosswater on: **0845 873 8840**

Or visit our web-site at [www.crosswater.co.uk](http://www.crosswater.co.uk)

The manufacturer reserves the right to make technical modifications without prior notice.

INSTALLATION INSTRUCTIONS

## INTRODUCTION

Please read these instructions carefully and keep in a safe place for future reference.

**General Installation Requirements.**

The installation must comply with regulations of the Local Water Authority as contained in their bylaws. All of the taps in this range are single flow (the hot and cold water mix in the body) and should therefore be supplied with hot and cold water at balanced pressures, both from the tank or both from the mains (via a combination boiler for example). If the taps are not supplied at balanced pressures then the mixer will not function correctly. It will also be necessary to fit non-return valves on both hot and cold feeds. It is very important that all pipework is flushed thoroughly after installation to avoid damaging the ceramic discs.

**Minimum/Maximum working pressure HP1**

These taps are suitable for high pressure installations. They are fitted with a half turn ceramic disc cartridge which provides a good flow rate with very smooth movement. The maximum water pressure is 6 bar (note: mains cold water is normally supplied at between 2 and 3bar). For installations where the mains pressure exceeds 6 bar a pressure reducing valve should be fitted.

The tap is fitted with an aerator for use in high pressure installations. If your water is supplied at low pressure you may prefer to change the nozzle to a flow straightener.

**Approvals**

All products are manufactured using materials tested and approved under the Water Bylaws Scheme and comply with requirements of British Standard 5412:1996 where applicable.

**Preparation and byelaw requirements**

These taps are single flow so the hot and cold water mix in the body. Water byelaws require that where the hot water is supplied from a tank and cold from the mains, non return valves are fitted on both hot and cold pipes as close as possible to the tap. These are not supplied. Where combination boilers are fitted it is only necessary to shut off the incoming mains and turn the boiler off and non return valves are not required.

**WARNING**

**Before installing the new mixer it is essential that you thoroughly flush through the supply pipes in order to remove any remaining swarf, solder or other impurities. Failure to carry out this simple procedure could cause problems or damage to the working of the mixer.**

These hints have been prepared for your guidance, you must exercise due care at all times. We do not accept responsibility for any problems that may occur through incorrect installation.

## DIMENSIONS

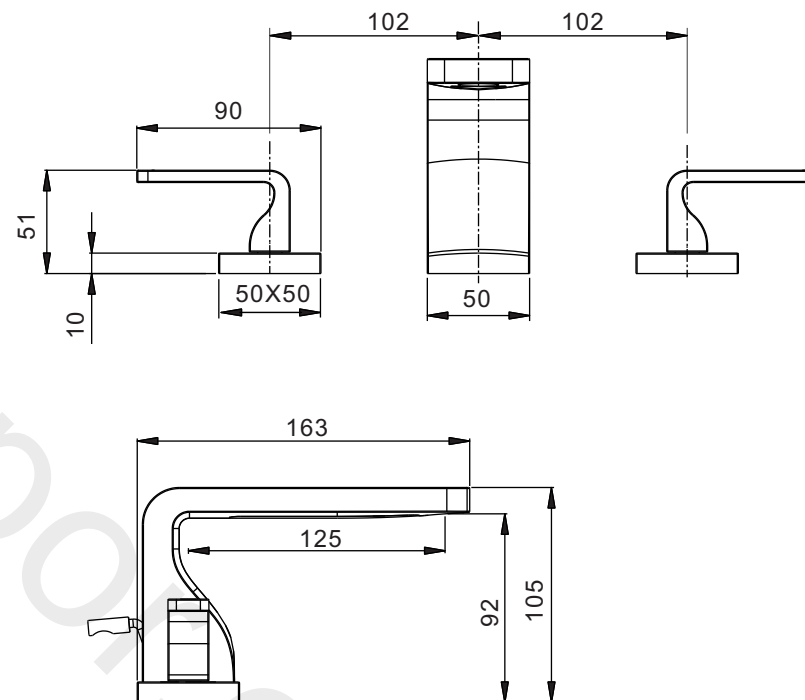

NOTE: ALL DIMENSIONS IN MILLIMETRES

INSTALLATION

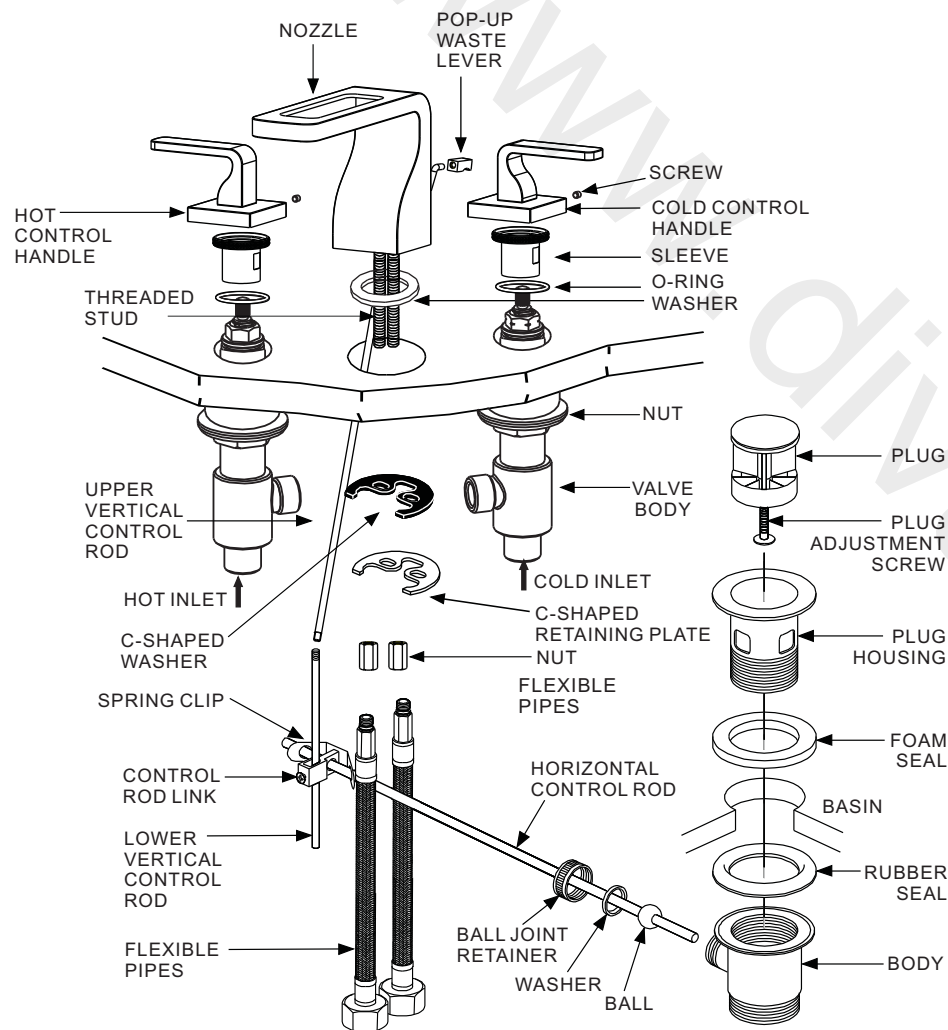

INSTALLATION

First shut off your water heating system then, with your mains stop cock closed, open the lowest hot and cold taps in the house and allow to run until the cold storage tank and pipes are empty (the hot water storage cylinder always remains full). Fitting isolating valves to the inlet feeds is recommended for ease of maintenance.

INSTALLATION



**Remember to turn off the mains water supply before connecting to any existing pipe work.**

The basin spout must be firstly screw the two flexible hoses (as illustrated) into the basin spout then inserted through the centre tap hole on the basin (or work top) ensuring that there is enough thread to tighten the spout to the unit. Slide the C- shaped black washer and then the metal retaining plate up the threaded screw and secure screwing the fixing nut with an adjustable spanner. Both side bodies must then be fitted (from the under-side of the basin or work top, without the chrome flanges fitted) making sure that the “back nuts ” are already screwed onto the threads. The outlets of both side bodies must then be aligned so that the flexible pipes can supply water to the spout (which have already been secured). Once this alignment is achieved the back nuts under the basin can be tightened to allow the chrome flanges to be fitted from above the controls. The copper pipes then need to be secured using the compression fittings and washers supplied for the hot and cold supplies. The Hot (to the left side) and Cold (to the right side) water supplies can then be connected to the 1/2” fittings at the bottom of each side body. The tap then must be examined for any leaks under the basin. The pop up waste must then be fitted as illustrated to the basin.

**Pop-up waste.**

Screw together the 2 sections of the vertical control rods and insert up through the C-shaped retaining plate and into the mixer. Insert the pop-up waste lever into the slot at the back of the mixer and screw in the control rod.

Assemble the pop-up waste to the basin, with the foam washer on top and the rubber washer below and hand tighten.

Prepare the horizontal control rod by sliding on the washer, ball joint retainer making sure the cup part of the washer will sit around the ball. Slide the control rod link onto the vertical control rod. Slide on end of the spring clip onto the horizontal control rod, push the horizontal control rod through the control rod link and slide on the other end of the spring clip.

Insert the short end (with ball) of the horizontal control rod into the body (the horizontal control rod can be slid through the control rod link by squeezing the ends of the spring clip) and clamp to the body with the ball joint retainer. Do not over tighten.

Test the action of the pop-up waste and fully tighten the rod link. Adjust the ball joint retainer as required.

**ATTENTION**

Having first checked all new connections, turn on the mains stop cock, close all taps except the new mixer and as the system starts to refill check for leaks.

Once you have satisfied yourself that there are no leaks, switch on the water heating.

**MAINTENANCE**

Once the valve has been set correctly the collar can be screwed down to secure the unit. The handle is then pushed onto the spline and tightened with the hex key.

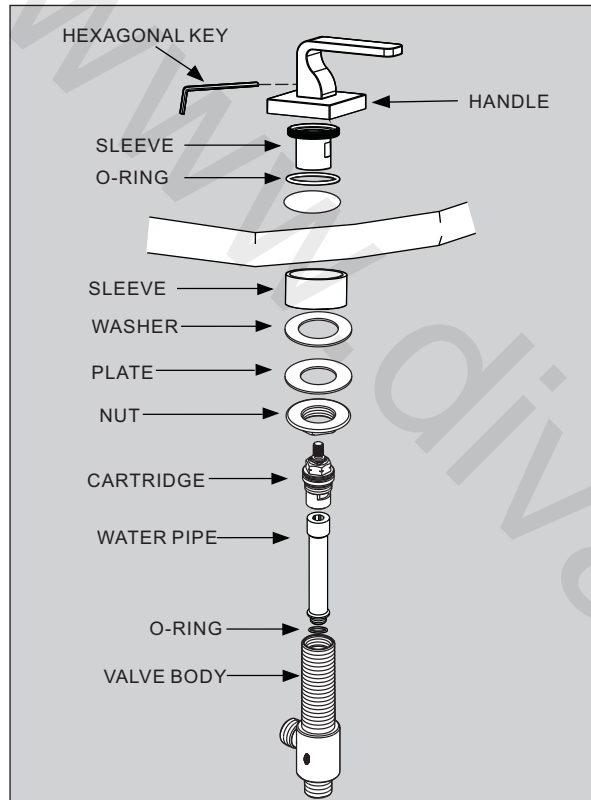

The hose is connected with the washer provided. A thread sealant may also be used such as PTFE tape.

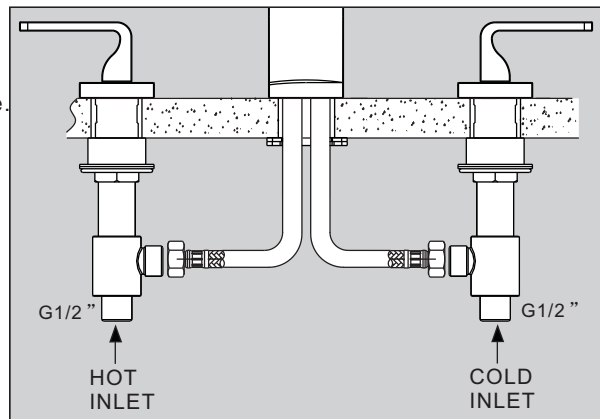

**CLEANING**

The chrome and gold plate we use on our taps is very durable, nevertheless care should be taken when cleaning them. They should be cleaned only with warm soapy water followed by rinsing with clean water and drying with a soft cloth. All finishes are vulnerable to acid attack and some strong substances such as household cleaners, disinfectants, denture cleaners, hair dyes, wine making and photographic chemicals can cause the surface to go black or peel.