

BRISTAN

TAPS & SHOWERS

Installation Instructions and User Guide

Infrared Automatic Basin
Spouts

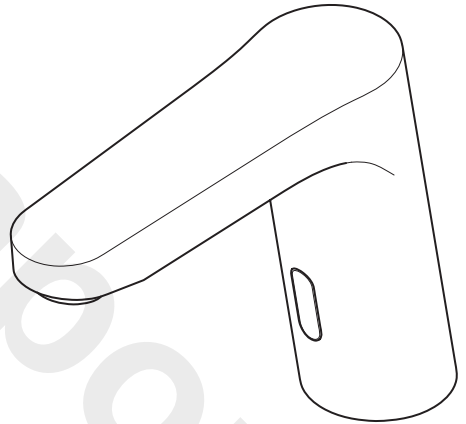

Models Covered:

IRBS1-CP, IRBS2-CP &
IRWS1-CP

**Please keep this booklet for future
reference.**

Installer, when you have read these
instructions please ensure you leave
them with the user.

Contents

Thank you for choosing Bristan, the UK's leading showers and taps expert.

Your Bristan basin spout has a non-touch control which uses infrared sensing technology to detect human presence. Once detected, the spout instantly dispenses water and automatically stops once the user moves their hands away to eliminate unnecessary water wastage, whilst creating a more hygienic washroom solution.

All products manufactured and supplied by Bristan are safe and comply to legislative requirements. Providing they are installed correctly and receive regular maintenance in accordance with these instructions your user experience will not be affected.

For a safe and successful installation these instructions should be used as guidance, thereafter they should be left with the user.

Contents

• Important Safety Information	3
• Specification	4
• Product Features	5
• Dimensions (mm)	6-7
• Installation Requirements	8
• Installation	9-12
• Installation - Electrical Connections	13
• Installation - Water Connections	14-15
• Operation	15
• Maintenance	16
• Troubleshooting	17-18
• Notes	19

Important Safety Information

- **Please read these instructions thoroughly and retain for future use.**

- All products manufactured and supplied by Bristan are safe provided they are installed, used correctly and receive regular maintenance in accordance with these instructions.

- **If you are in any doubt about your ability to install this product safely you must employ the services of an experienced qualified plumber/electrically qualified person.**



- **Warning:** Do not operate the product if you suspect it is frozen. Do not site the product where it might be subjected to freezing conditions.

- These fittings need to be installed in accordance with, and meet the requirements of the Water Supply (Water Fittings) Regulations 1999 and current byelaws.

- Remove all packaging and check the contents for damage before starting installation

- Before starting any installation please consider the following: before drilling into walls, check that there are no hidden electrical wires, cables or water supply pipes. This can be checked with the aid of an electronic detector.

- If power tools are used do not forget to:

- Wear eye protection
- Unplug equipment after use

- Fitting isolating valves to the inlet feeds is required for ease of maintenance.



- **Warning:** Before installing the new spout it is essential that you thoroughly flush through the pipework in order to remove any remaining swarf, solder, etc. Failure to carry out this procedure could cause problems or damage to the workings of the spout.

- This product **must** not be modified in any way as this will invalidate the guarantee.



Specification

Power Supply Box Inlet Connection: G1/2"

Power Supply Box Outlet Connection:

G1/2"

Operating Pressure Range: Min. 1.0 Bar - Max. 5.0 Bar

Maximum Static Pressure: 10 Bar

Inlet Water Supply Temperature Range:

5°C - 45°C

Power Supply: AC: 220V-240V; 50/60HZ

DC: 6V (4 x AA alkaline batteries - Not Supplied)

Power Consumption: Static <0.3MW

Active: <3W

Sensing Range: 23-26cm

Self-close Override Time: 55 seconds ± 5 seconds

This product has been tested to meet the requirements of the Water Regulations Advisory Scheme (WRAS) and satisfies the requirements of the Water Supply (Water Fittings) Regulations 1999 and current byelaws.

BS 6700 recommends the temperature of stored water should never exceed 65°C. A stored water temperature of 60°C is considered sufficient to meet all normal requirements and will minimise the build up of limescale in hard water areas.

This product should be installed in compliance with the current Water Regulations.

If in doubt, contact a registered plumber or your Local Water Authority or the Secretary of The Institute of Plumbing, address as follows;-

The Institute of Plumbing,
64 Station Lane,
Hornchurch,
Essex, RM12 6NB
Tel:01708 472791

Recommended Usage			
Domestic	X	Heavy Commercial	✓
Light Commercial	✓	Health Care	X

Product Features

Water Efficient

When the users hands enter the sensing range, the indicator light in the sensor will illuminate. Water will flow out immediately until the user draws their hands back from the sensor.

The water will automatically stop after a maximum of 55 seconds \pm 5 seconds to avoid wasting water. If more water is required wait 4 seconds and then place hands back in the sensing range.

More Hygienic

The proximity sensor removes the need to touch the spout body, reducing the spread of germs and reducing the chance of cross infection.

Battery Override

In the event of a power failure, the product will automatically switch to battery operated mode to ensure the spout continues to function. The tap can also operate on the battery alone if no mains power source is available.

Low Battery Warning

When the batteries run low and the power falls below 3.9V the sensor light will flicker to indicate the batteries are running low and need replacing.

When the batteries are exhausted the sensor light will not light up.

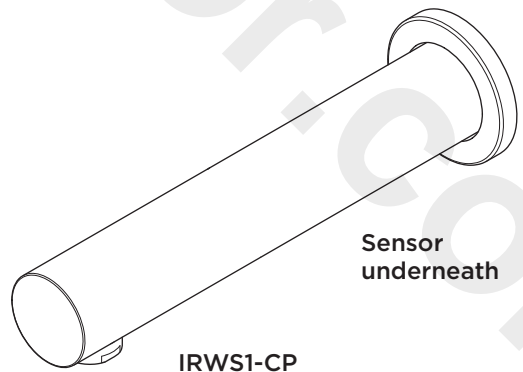
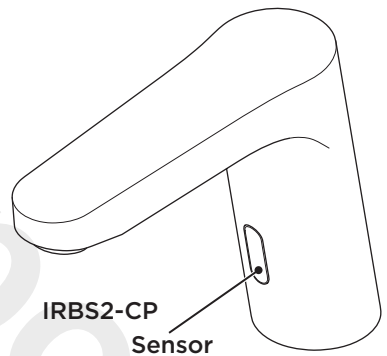
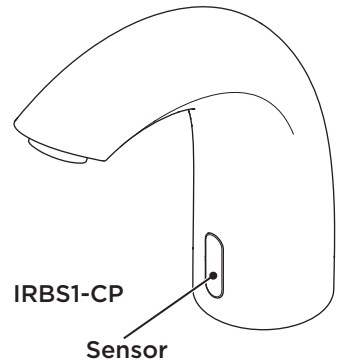

Dimensions (mm)

IRBS1-CP

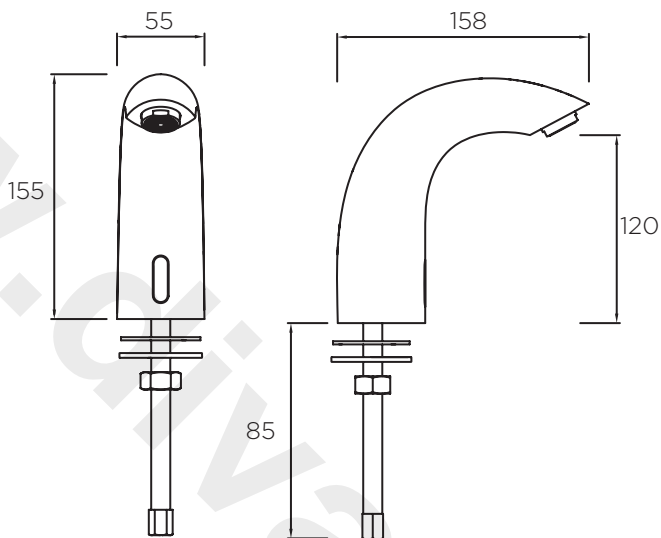

IRBS2-CP

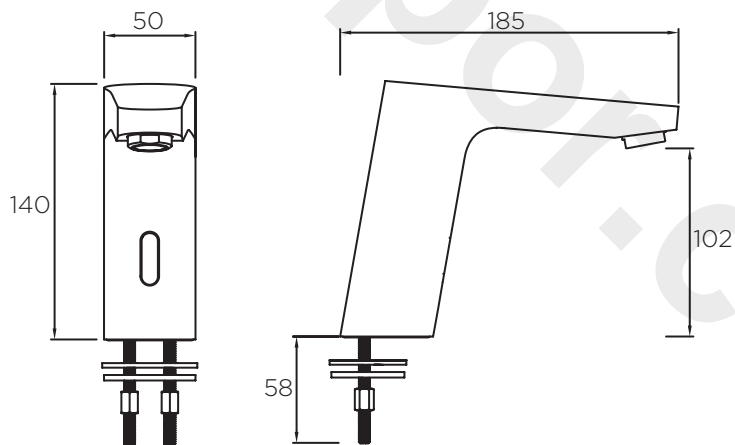

Dimensions (mm)

IRWS1-CP

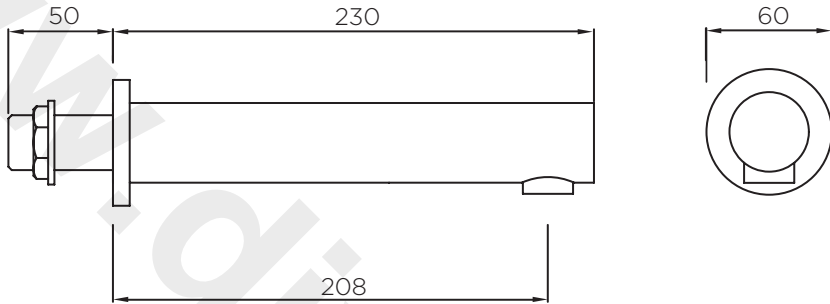

Power Supply Box

IRBS1-CP & IRBS2-CP

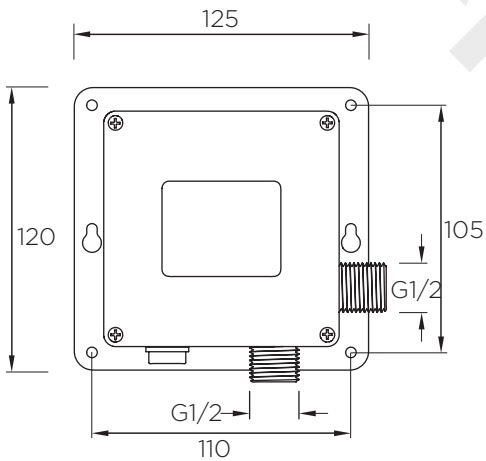

IRWS1-CP

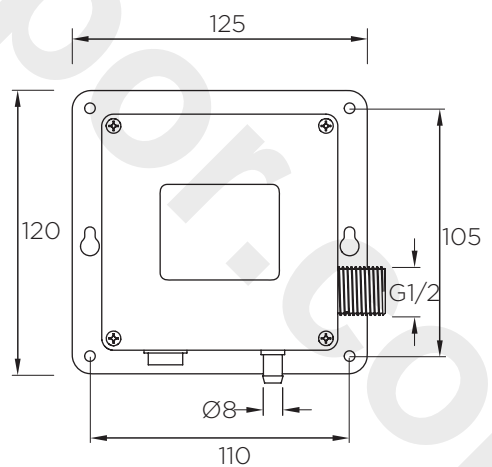

Installation Requirements

Electrical Connections

Regulations: The electrical installation must be carried out in accordance with the national electrical regulations and installed by a qualified person.

Safety: In the interests of electrical safety a 30 mA residual current device (R.C.D not supplied) should be installed in the supply circuit. This may be part of a consumer unit or a separate unit.

Before starting work on the electrical supply ensure the power supply is isolated.

DO NOT allow the supply cord to contact hot surfaces. The cord should be safely routed and secured by cable clips.

Connections: The power supply box must be permanently connected to the fixed wiring of the mains supply using the factory fitted supply cord, via a switched fused spur off the ring main.

The wires in the mains lead are coloured in accordance with the following code:

Blue: Neutral

Brown: Live

As the colours of the wires in the mains lead of this appliance may not correspond with the coloured markings identifying the terminals in your connection unit proceed as follows;-

The wire which is coloured blue must be connected to the terminal which is marked with the letter 'N' or is coloured black.

The wire which is coloured brown must be connected to the terminal which is marked with the letter 'L' or is coloured red.

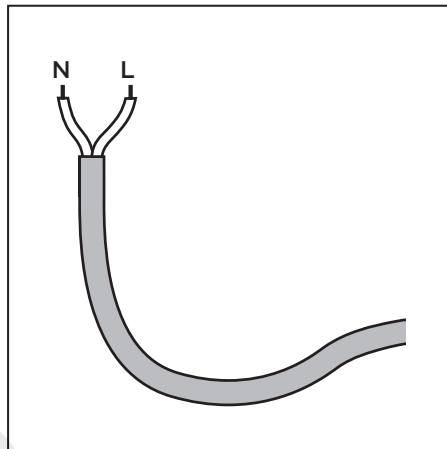

Fuse: This following fuse size should be used.

Model	Fuse Size (AMPS)
IRBS1-CP	3
IRBS2-CP	3
IRWS1-CP	3

Supply Cord Replacement

If the supply cord is damaged, it must be replaced by a genuine Bristan supply cord. Contact Bristan Customer Services on 0330 026 6273 to request new spare parts.

Installation

IRBS1-CP

1. Fit The Spout

Fit the spout to the sink / work surface ensuring the sensor cable is threaded through the hole in the sink / work surface.



Important: It is advised to ensure that the product is at least 360mm away from

reflective surfaces to prevent the tap from automatically switching on and off.

2. Secure Spout to Sink/Work Surface

Thread the rubber washer and metal washer onto the fixing rod up to the underside of the sink/work surface.

Secure the spout in place by screwing the fixing nut onto the fixing rod.

Tighten the fixing nut using a suitable spanner.

3. Connect Sensor Cable

Go to the 'Electrical Connections' section.

4. Connect Water Supplies

Screw the flexi hose into the bottom of the fixing rod, ensuring it is **tightened fully by hand only**.

Connect the flexi hose to the power supply box. Go to the 'Water Connections' section.

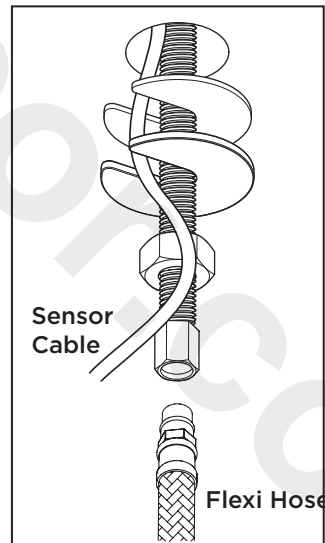
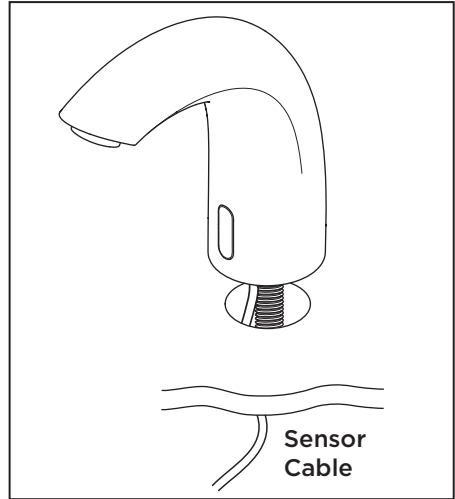

Installation

IRBS2-CP

1. Fit The Spout

Screw the fixing rods into the bottom of the spout.

Fit the spout to the sink / work surface ensuring the sensor cable is threaded through the hole in the sink / work surface.



Important: It is advised to ensure that the product is at least 360mm away from

reflective surfaces to prevent the tap from automatically switching on and off.

2. Secure Spout to Sink / Work Surface

Thread the rubber washer and metal washer onto the fixing rods up to the underside of the sink / work surface.

Secure the spout in place by screwing the fixing nuts onto the fixing rods.

Tighten the fixing nuts using a suitable spanner.

3. Connect Sensor Cable

Go to the 'Electrical Connections' section.

4. Connect Water Supplies

Screw the flexi hose into the bottom of the spout, ensuring it is **tightened fully by hand only**.

Connect the flexi hose to the power supply box. Go to the 'Water Connections' section.

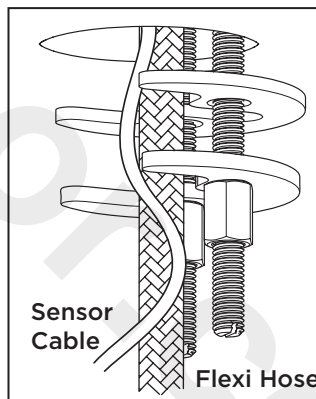
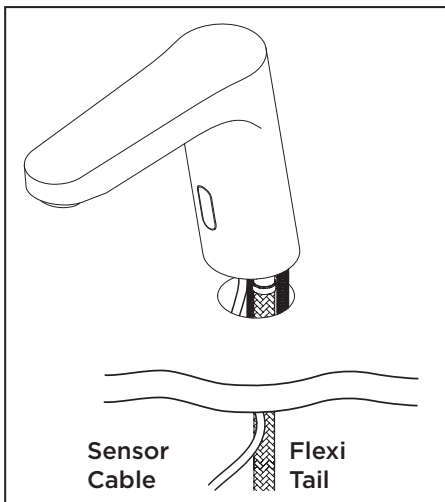

Installation

IRWS1-CP

1. Fit The Spout

Create a 27-30mm hole in the wall surface. Thread the sensor cable and hose through the hole along with the threaded tail.



Important: It is advised to install the spout to a partition/false wall to ensure access is available for future maintenance.

Also ensure that the product is at least 360mm away from reflective surfaces to prevent the tap from automatically switching on and off.

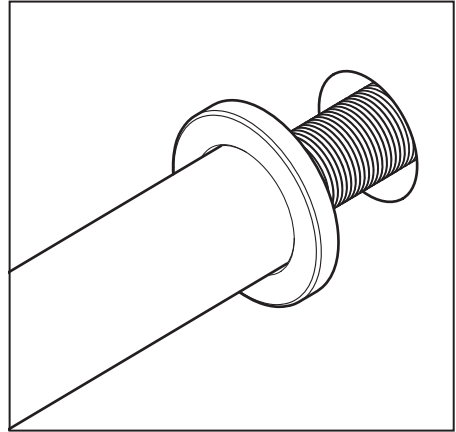

2. Secure Spout To Wall

Secure the Spout in place by screwing the backnut onto the threaded tail and tighten fully.

Note: A suitable spanner maybe required to fully tighten the backnut.

3. Connect Sensor Cable

Go to the 'Electrical Connections' section.

4. Connect Water Supplies

Go to the 'Water Connections' section.

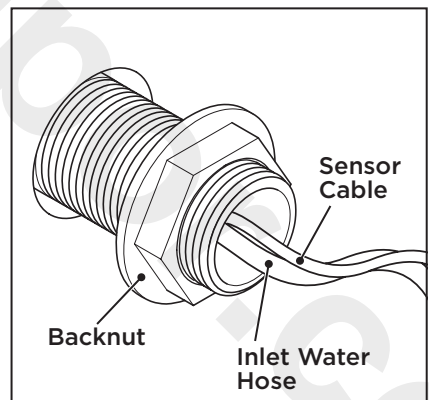

Installation

Inserting Batteries

Your infrared spout is supplied with a back up battery pack. In the event of a power failure the batteries will override the mains power supply to ensure the spout continues to function.

Note: If you do not have a mains power supply, this product can run off the battery pack.

Before fitting the power supply box into position on the wall/floor, batteries (not included) will need to be fitted.

1. Remove Power Supply Box Cover

Remove all four screws in each corner of the power supply box and remove the cover.

2. Remove Battery Box

Remove the battery case from the power supply box and remove the screw in the centre of the case.

3. Insert Batteries

Insert 4 x AA batteries into the battery box ensuring they are inserted the correct way.

Note: Only use 1.5V AA (LR6) Alkaline batteries (preferably => 2000mAh for good battery life).

4. Replace Battery Box

Replace the battery case cover. Replace and tighten the screw. Insert the battery case back into the power supply box.

5. Replace Power Supply Cover

Replace the power supply cover and tighten all 4 screws ensuring they are all fully tightened.

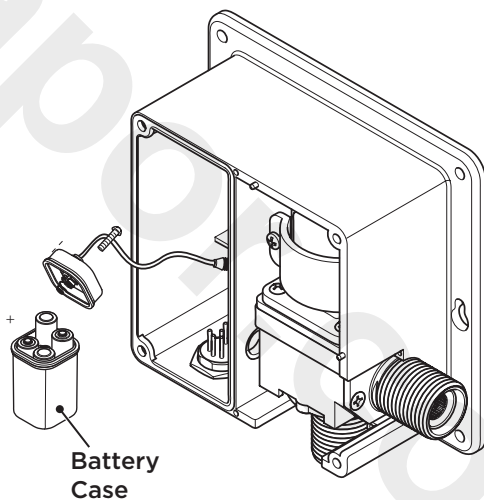
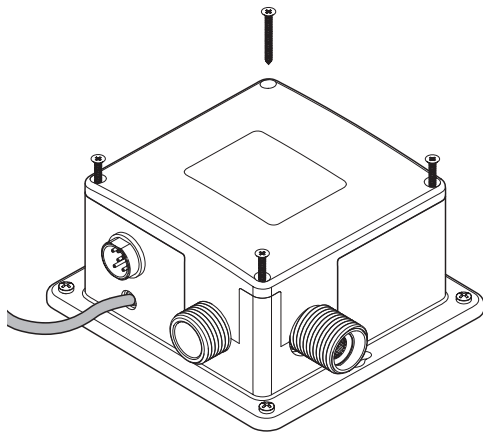

Installation - Electrical Connections

1. Position Power Supply Box

Position the power supply box onto the wall surface below the sink/work surface where it is easily accessible.

Note: Ensure that the power supply box is fitted the correct way up (see opposite) and that the flexible hose will reach from the underside of the spout to the power supply box.

Using suitable fixings for the wall type secure the power supply box to the wall.

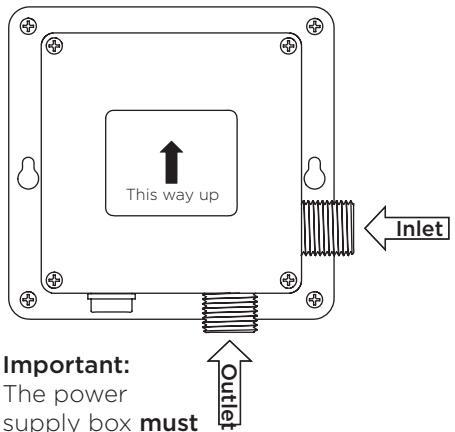

Important:
The power supply box **must** be installed this way up.

2. Connect Power Supply Cable

Before starting any electrical work ensure the power supply is isolated. Wire the electrical power cable into a switched fused spur off the ring main.

The blue wire should be wired to the neutral connection and the brown wire should be connected to the live connection.

Note: For full electrical requirements see 'Electrical Connections' in 'Installation Requirements' section on page 9.



Important: The power supply box must be permanently connected to the fixed wiring of the

mains supply using the factory supplied power cable.

3. Plug In Power Cable

Plug the power cable into the power supply box.

4. Connect The Sensor Cable

Plug the sensor cable from the spout into the power supply box to activate the infrared sensor.

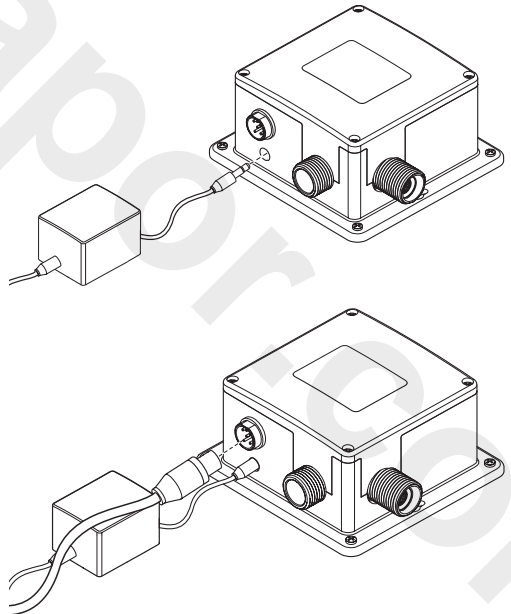

Installation - Water Connections

Connecting Water Supply

A blended water supply is required to the inlet of the power supply box.

Before connecting the water supply to the power supply box flush through the pipework to ensure removal of debris.

Once flushed through turn off the mains water supply and close any isolating valves.

Inlet Connection

The inlet connection on the power supply box is a 1/2" BSP male threaded connection.

Connect a 1/2" BSP female connector to the inlet connection ensuring a suitable sealing washer is used to create a water tight connection.

Outlet Connection

IRBS1-CP & IRBS2-CP

The outlet connection on both the IRBS1-CP and IRBS2-CP is a standard 1/2" BSP male threaded connection.

Connect the flexi hose (supplied) to the outlet connection, ensuring it is tightened fully.

IRWS1-CP

The IRWS1-CP is supplied with a 1320mm outlet hose pre-fitted to the spout. Push the outlet hose onto the outlet spigot on the power supply box.

Ensure the outlet hose is fully pushed onto the outlet spigot and crimp the hose clamp using a pair of pliers to secure the hose onto the spigot.

IRBS1-CP & IRBS2-CP

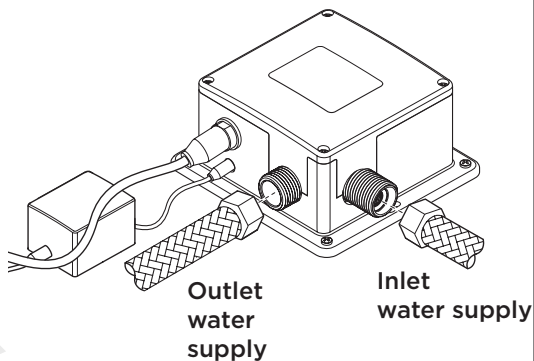

IRWS1-CP

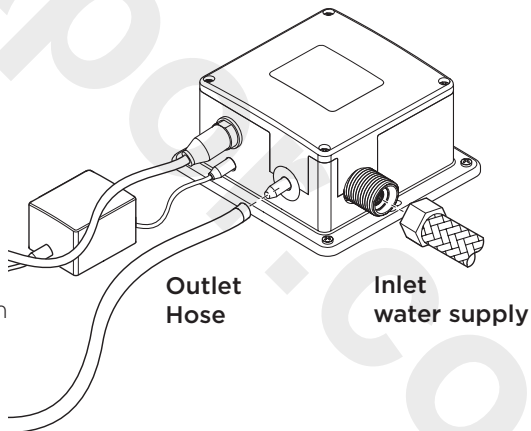

Installation - Water Connections

Flexible Connecting Hose

Care must be taken when connecting the flexible connection hose from the power supply box to the spout to ensure it does not bend sharply and kink or twist.

See below for recommended ways to fit the flexible connecting hose.

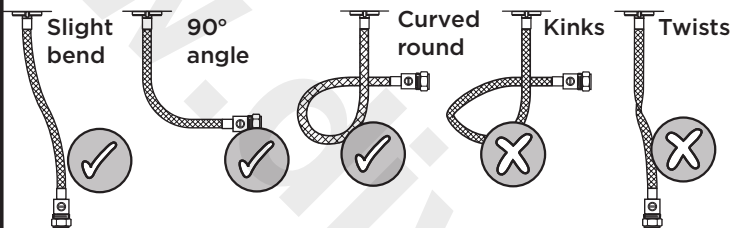

Important:

Failure to follow these guidelines may result in poor performance and damage to the flexible connection hose.

Operation

Using the Automatic Basin Spout

Place the users hands under the spout within the sensing range. Once the users hands have been detected water will flow constantly until the hands are removed.

After 55 ± 5 seconds the water will stop flowing.

If the user requires more water remove hands from the sensing range and wait 4 seconds, then place the hands back into the sensing range and the water will flow again.

Note: The sensing range for all models is 23-26cm from the sensor.

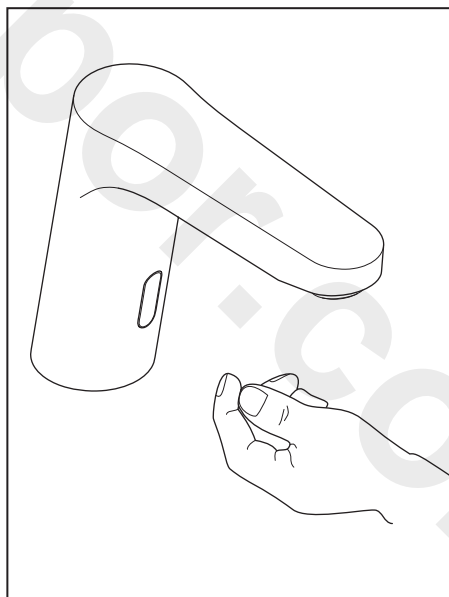

Maintenance

General Cleaning

Your fitting has a high quality finish and should be treated with care to preserve the visible surfaces. All surfaces will wear if not cleaned correctly, the only safe way to clean your mixer is to wipe with a soft damp cloth. Stains can be removed using washing up liquid. All bath cleaning powders and liquids will damage the surface of your fitting, even the non-scratch cleaners.

Note: Never use abrasive detergents or disinfectants or those containing alcohol, hydrochloric acid or phosphoric acid.

Cleaning the Inlet Filter

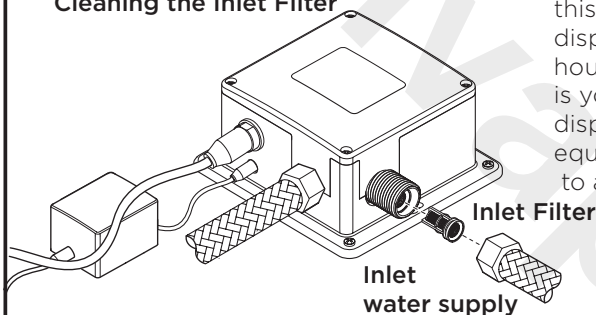

Before carrying out any maintenance, turn off the mains water supply and close any isolating valves.

In hard water area it may be necessary to regularly clean the inlet filter in the power supply box to maintain optimum performance of the infrared spout.

Remove the inlet supply connection and remove the inlet filter. Run under cold water to remove any build up of limescale and debris. Replace the filter and re-attach the inlet connection, ensuring that the sealing washer is also refitted.

Disposal and Recycling

End of Product Life

When this appliance has reached the end of its serviceable life, it should be disposed of in a safe manner, in accordance with current local authority recycling, or waste disposal policy.

Battery Disposal

Spent batteries should not be disposed of with normal household waste. Contact your local authority for information on waste disposal and recycling.

This symbol on the product or packaging indicates that this product should not be disposed of with your other household waste. Instead, it is your responsibility to dispose of your waste equipment by handing it over



to a designated collection point for the recycling of waste electrical and electronic equipment. The separate collection and recycling of your waste equipment at the time of disposal will help to conserve natural resources and ensure that it is recycled in a manner that protects human health and the environment.

For more information about where you can drop off your waste equipment for recycling, please contact your local council office, your household waste disposal service or the shop where you purchased the product.

Troubleshooting

Symptom	Cause	Remedy
Spout does not operate e.g no water flow.	Sensor cable not connected.	Check that the sensor cable is connected. If not connected, connect sensor cable. Refer to the 'Electrical Connections' section.
	Water supply not turned on.	Turn on water supply and open any isolation/service valves.
	Solenoid valve not opening.	Contact Bristan Customer Services.
	No mains electrical power to the power supply box.	Connect power supply cable. Refer to the 'Electrical Connections' section.
	Blockage in water supply pipework.	Remove pipework and flush to remove any debris. Remove inlet filter and clean under running water.
	Inlet water supply pressure too low.	Refer to 'Specification' section for working pressures.
No power to the power supply box.	No Mains power to the power supply box.	Connect power supply cable. Refer to the 'Electrical Connections' section.
	Mains power supply failed and no batteries fitted or batteries low.	Check mains power supply. Insert/change batteries. Refer to 'Installation - Inserting batteries' section.
Flow or water too low	Inlet filter is partially blocked.	Clean inlet filter. Refer to 'Maintenance' section.
	Partially closed stop or service valve in water supply pipework.	Open stop or service valve.
	Inlet water supply pressure too low.	Adjust inlet water pressure accordingly. Refer to the 'Specification' section.

Troubleshooting

Symptom	Cause	Remedy
Flow of water too high.	Inlet water supply pressure too high.	Adjust inlet water pressure accordingly. Refer to the 'Specification' section.
Spout runs randomly without a user present.	Object in the sensing range.	Ensure the sensing range is clear.
Sensor light not working.	Sensor light faulty.	Contact Bristan Customer Services.
	Circuit board faulty or has been allowed to get wet.	
	Batteries are exhausted.	Replace batteries.
Short cycles of batteries.	Incorrect batteries fitted.	Replace batteries. Ensure batteries are 1.5V AA (LR6) Alkaline batteries (preferably =>2000mAh) for good battery life.
Infrared sensor flickering.	Batteries running low.	Replace batteries. Ensure batteries are 1.5V AA (LR6) Alkaline batteries (preferably =>2000mAh) for good battery life.

Notes

www.divapor.com

Issue: D5

Part Number: FI Infrared Spouts

BRISTAN

TAPS & SHOWERS

Bristan Group Ltd.

Birch Coppice Business Park
Dordon
Tamworth
Staffordshire
B78 1SG

Web: www.bristan.com

Email: enquire@bristan.com

A Masco Company

At Bristan, we want to make things as easy as possible for our customers. That's why we offer solid guarantees on all our products, effective from the date of purchase, to give you peace of mind. To start your free guarantee simply scan the QR code and register your product. Alternatively visit www.bristan.com/register.

For any other queries, please call our Customer Service on 0330 026 6273 where our expert team of advisors will be able to offer you any help and advice. For full guarantee terms and conditions visit www.bristan.com/guarantees.



We Know & We Care