

# inta

---

## Infra Red Modern Basin Tap

### IR411CP & IR412CP

## Installation and Maintenance Instructions



# inta

**Intatec Ltd**

Airfield Industrial Estate  
Hixon  
Staffordshire  
ST18 0PF

Tel: **01889 272 180**

Fax: **01889 272 181**

email: **sales@intatec.co.uk**

web: **www.intatec.co.uk**

In this procedure document we have endeavoured to make the information as accurate as possible.

We cannot accept any responsibility should it be found that in any respect the information is inaccurate or incomplete or becomes so as a result of further developments or otherwise.

## Introduction

This installation guide has been produced for the IR411CP & IR412CP infra red modern basin taps. These instructions cover the installation, operation and maintenance. Please read the enclosed instructions before commencing the installation of this product, please note;

**We recommend that the installation of any Inta product is carried out by an approved installer.**

## Products

Infra red modern basin mounted tap battery operated	IR411CP
Infra red modern basin mounted tap with mains operated	IR412CP

## Check Contents

Before commencing remove all components from packaging and check each component with the contents list.

Ensure all parts are present, before discarding any packaging. If any parts are missing, do not attempt to install your Inta electronic tap until the missing parts have been obtained

Item	Components
1	Tap with infra red sensor
2	'O' ring seal
3	Flexible pipe
4	Threaded rod and nut
5	Gasket
6	Horse shoe washer
7	Filter sealing washer
8	Plug and transformer - IR412CP
9	Battery box - IR411CP

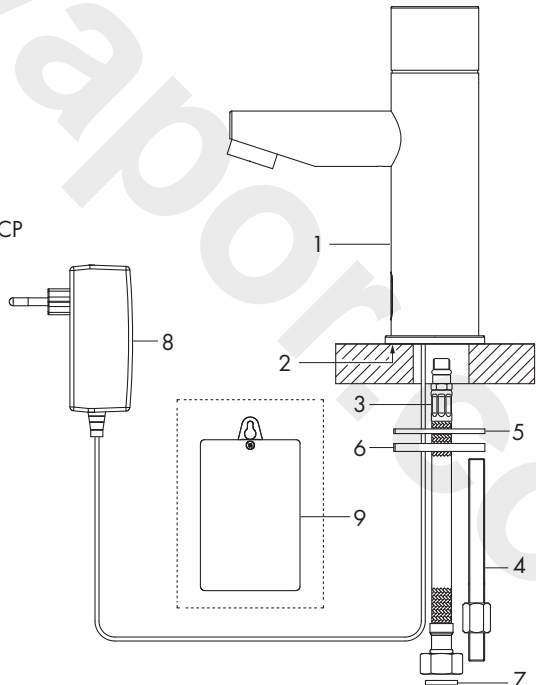

## Technical Data

Power specification:	9V low voltage system
Power source:	IR411CP: 6 x 1.5V AA batteries IR412CP: 9V transformer
Operating water pressure:	0.5 to 8.0 bar (7 to 116 psi) With water pressure in excess of 8 bar use with a pressure reducing valve.
Hot water temperature:	70°C maximum - To limit the outlet temperature to 41°C max. we recommend using the Intamix Thermostatic Mixing Valve code 40015CP.
Preset sensor range:	200mm (adjustable with remote control)
Minimum sensor range:	35mm
Maximum sensor range:	300mm
Security time:	90 seconds (can be reduced with remote control)

## Dimensions

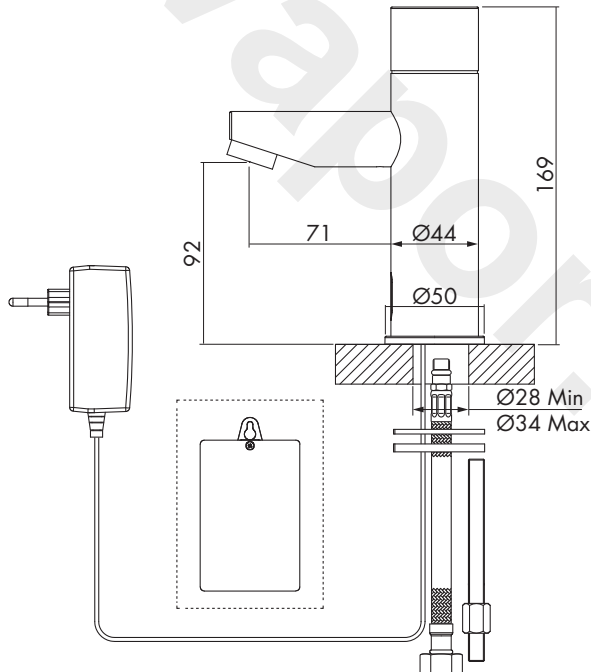

## Pre-installation Information

### Warning

Do not install the tap facing a mirror or any other electronic system operated by an infra red sensor.

This tap is also vulnerable to stray sensor readings from users wearing high visibility or other reflective clothing.

To prevent reflection problems, it is recommended to keep a minimum distance of 1.5m between the tap and other objects.

### Preparation for installation

Flush the water supply pipes thoroughly prior to installation. Do not allow debris, PTFE tape or any metal particles to enter the tap.

Do not expose to temperatures below 5°C, for example during winter. If the tap will be exposed to freezing conditions the tap and system should be drained.

**Important:** All plumbing is to be installed in accordance with applicable codes and regulations.

## Installation

1. A service valve should be installed in the water supply pipe to the valve should maintenance be required in the future.
2. Turn off the water supply using the service valve (not supplied).
3. Fit the flexible pipe (3) and threaded rod (4) to the tap.
4. Install the tap (1) to the basin using 'O' ring (2), gasket (5) and horse shoe washer (6).
5. Connect the flexible hose using the filter sealing washer (7) to service valve (not supplied) or water supply.
6. Fix the battery box to the wall using double sided tape or a wall plug and screw.
7. Connect the signal cable to the tap.
8. Turn on the water supply and check all joints for leakage.
9. Isolate via the service ball valve and tighten or remake joints if leakage occurs.

## Connecting the power supply

1. Check that the sensor window is clean and that there are no obstructions in front of the window.
2. Insert batteries into the battery box or connect the transformer to electricity supply.
3. Connect the power supply to the tap.
4. The LED under the sensor window will start flashing, when it stops the tap is ready for use.

### IMPORTANT:

This product must be installed by a suitably qualified and competent person carrying the relevant current IEE electrical qualification.

## Remote Control Handset



## Sensor Range

The sensing range of the tap is preset and should not require adjustment.

If however the range needs to be adjusted it can be, using the following procedure;

- Shut off the water supply using the service valve.
- Hold the remote control straight in front of the sensor a distance of between 150 to 200mm.
- Choose the function you want to adjust by pressing once on of the function buttons.
- After pressing once on a specific button, the LED at the front of the sensor will flash quickly.
- The settings can now be changed by pressing the (+) or the (-) buttons, every push will increase or decrease one level.
- After finishing the adjustment, turn on the water supply.

## Function Buttons



**DETECTION RANGE:** Only if necessary, use the remote control to adjust the sensor range as follows:

Press the RANGE BUTTON, wait until the LED in the sensor flashes, then press (+) to increase or (-) to reduce the range, every push will increase or decrease one increment.

NOTE: Once the detection range has been changed with the remote control, this distance will be remembered by the sensor, even if the power supply is disconnected.

**DELAY IN TIME:** If required, the delay in time can also be modified as follows:



Press the IN button, wait until the LED in the sensor flashes, then press + to increase the delay in time and - to reduce it.



**DELAY OUT TIME:** This button allows modifying the flushing start time after the user moves away from the tap. A delay out time close to 0 will save more water. An increased delay out time will make the user experience more comfortable.

If required, the delay out time can be modified as follows:

Press the OUT button. Wait until a quick flashing of the LED in the sensor eye is perceived. Then, press + to increase the delay out time and - to reduce it.



**TEMPORARY OFF FUNCTION:** This function is ideal to perform any kind of activity in front of the sensor without operating the system (for example, cleaning).

The product will remain shut for 1 minute when this button is pressed once. To cancel this function and to return to normal operation press the On/Off button again or wait 1 minute.



**RESET BUTTON:** This function restores all the factory settings except for the sensor range. If required, press the Reset button and without releasing it, press the + button once.



**SECURITY TIME:** The security time prevents continuous flushing of water from the tap due to reflections or vandalism. By default, if the sensor is covered for more than 90 seconds the water flow will shut automatically. To resume regular operation any obstruction must be removed.

Press the SEC button. wait until the LED in the sensor flashes, then press (+) to increase the security time and (-) to reduce it.



**24 HOUR HYGIENE FLUSH:** This model includes a 24 hours hygiene flush which is disabled. To activate the hygiene flush, press the clock button.

Wait until the LED in the sensor flashes, then press (+) to activate the hygiene flush. To disable it again, press (-) to deactivate it.



**COMFORT FLUSH:** If the tap has a COMFORT FLUSH setting it can be activated by pressing the flush button.

When the button is pressed, one blink of the LED in the sensor eye indicates the pre-programmed flush cycle will take place then.

The Comfort flush cannot be interrupted or deactivated by pressing any button until it is over.

## Prevention of Flooding

To prevent flooding the wash room following an act of vandalism or carelessness - an object left in front of the sensor or dirty sensor, the tap has a safety device that shuts off the water flow after approximately 90 seconds.

Once the object has been removed or the sensor cleaned, the tap will start working again.

## Aftercare

- Inta taps have a high quality finish and should be treated with care.
- An occasional wipe with a mild washing-up liquid on a soft damp cloth followed by a thorough rinsing is all that is required.
- Do not use an abrasive or chemical household cleaner as this may cause damage.
- Cleaning the sensor - the darkened window which protects the sensor must always be clean in order for the tap to operate correctly; do not use abrasive material to avoid damaging the plastic surface.
- Cleaning the water supply filter (7) - water can contain impurities which could damage the solenoid valve. For this reason the inlet to tap has a gasket with an integral filter in the inlet connection of the flexible hose which must be kept clean in order to ensure a suitable water flow.

**CAUTION: turn off the water supply using the service valve before unscrewing the joint to remove the filter gasket for cleaning.**

## Battery Replacement - IR411CP

When the batteries are exhausted, the LED blinks continuously and the solenoid valve stops in the closed position, replace the batteries and recycle the used batteries correctly.

## Warranty

### Limited Warranty

This product is covered by a limited warranty for one year from the date of purchase.

During this period Intatec Ltd undertakes, at its option, to repair or replace any faults caused by defective material or manufacturing faults that may arise (see Intatec Warranty).

This guarantee does not cover faults or damage caused by incorrect installation and/or maintenance, wear and tear, battery or water composition (eg hard water), this includes but is not limited to the following:

- Incorrect installation, inversion of supply pipes.
- Pressure or temperatures exceeding the recommended limits.
- Improper use, tampering, bad or lapsed maintenance.
- Foreign bodies, dirt or scale introduced by the water supply.

## Trouble Shooting

Problem	Indicator	Cause	Solution
No water flow from tap	Sensor flashes continuously when the user's hands are within the sensor's range	Check service valve is closed	Open service valve
		Exhausted battery	Replace battery
	LED in the sensor does not flash once when the user's hands are within the sensor's range	Range is too short	Increase range
		Range is too long	Decrease range
		Battery is exhausted	Replace battery
		Tap is in 'Security Mode'*	
	LED in the sensor flashes once when the user's hands are within the sensor's range	Sensor is picking up reflections from wash basin or another object	Remove cause of reflection
		Connectors between power supply and the tap are disconnected	Connect the tap to the power supply
		Debris or scale in solenoid	Unscrew solenoid, pull out the plunger and spring and clean them. Use scale remover if needed. When replacing the plunger, ensure the spring is in the vertical position
		The central orifice in the diaphragm is plugged or the diaphragm is torn	Clean the diaphragm or replace the diaphragm
		Water supply pressure is above 8 bar	Reduce the pressure of fit a pressure reducing valve
		The supply pressure is below 8 bar and yet the pressure in the tap body is higher. This could be caused by a sudden increase in water pressure which the check valve prevents from reducing	Shut off the water supply and unscrew the flexible pipe to reduce the pressure
Water flow from spout does not stop	Sensor flashes once when user's hands are within range	Debris or scale in diaphragm	Clean orifice or replace diaphragm
	LED does not flash when users's hands are within range	Sensor is dirty or covered **	Clean sensor or remove source of interference
		Sensor is picking up reflection from wash basin or another object	Decrease or eliminate cause or reflection
Water flow reduces		Filter or aerator is blocked	Remove, clean an reinstall

## Trouble Shooting

- \* 'Security Mode': If the sensor is covered for more than 90 seconds the tap will automatically shut off the water flow. To return to normal operation remove the obstruction.
- \*\* In this case, the water flow will stop anyway after 90 seconds due to the security time.

## Battery Replacement

When the batteries weaken, the red indicator light will flash at a constant rate.

The batteries must be replaced within 2 weeks.

To replace the batteries:

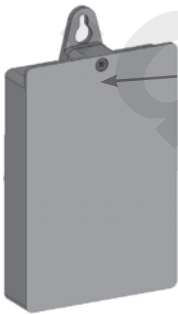

1. Unscrew the retaining screw

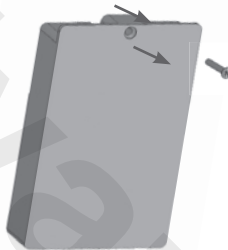

2. Carefully open the battery box

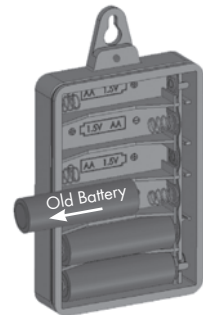

3. Remove the old batteries

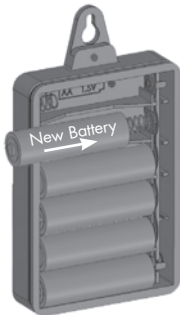

4. Replace the used batteries with 6 x 1.5 V batteries  
Lithium batteries recommended



5. Replace the cover



**IMPORTANT:** Spent batteries should not be disposed of with normal household waste. Contact the local authority for information on waste disposal and recycling.



## Notes

www.divapor.com

## Notes

www.divapor.com

# inta

---

## **Please leave this Manual for the User**

To activate your product warranty please visit  
**[www.intatec.co.uk](http://www.intatec.co.uk)**  
and click on Product Registration

# inta

**Intatec Ltd**

Airfield Industrial Estate  
Hixon  
Staffordshire  
ST18 0PF

Tel: **01889 272 180**

Fax: **01889 272 181**

email: **[sales@intatec.co.uk](mailto:sales@intatec.co.uk)**

web: **[www.intatec.co.uk](http://www.intatec.co.uk)**

E & O.E