

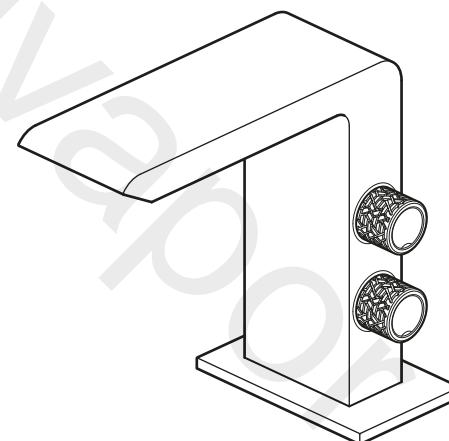

INDIVIDUAL
by VADO



OMIKA NOIR

Mono basin mixer

—

INSTALLATION GUIDE

VADO
Wedmore Road, Cheddar,
Somerset, England BS27 3EB
tel 01934 744466
fax 01934 744345
www.vado.com
sales@vado.com

Version 1, 1-7-2021

INDIVIDUAL
by VADO

Important - please read

Please read these instructions carefully before starting installation and keep for future reference.

Remove all packaging and check the product for missing parts or damage before starting installation.

Any alterations made to this product and fittings may infringe water regulations and will invalidate the guarantee.

The installation must comply with all Local/National Water Supply Authority Regulations/Byelaws and Building and Plumbing Regulations.
To be installed in accordance with BS EN806.

We strongly recommend that you use a qualified and registered plumber.

General installation

This fitting is a mixing device and therefore water supplies should be reasonably balanced.

When installed, the fitting must comply with the requirements of the Water Supply (Water Fittings) Regulations 1999 and Scottish Byelaws 2004. Please check with your local water undertaker if there is any uncertainty.

Before making any inlet pipe connections, all supply pipes MUST be thoroughly flushed to remove debris. Failure to do so could result in damage or low flow from the mixer unit. Water Supply (Water Fittings) Regulations 1999 Schedule 2 Section 13.

The fitting of isolating valves to the inlet feeds is advised for ease of maintenance.

Please take great care when installing this mixer not to damage its surface.

Please note if installing in an enclosed environment, access should be left for servicing and maintenance. No costs relating to inadequate access can be accepted.

Operating Specifications

Operating Pressure

Minimum operating pressure - **1 bar**

Maximum operating pressure - **5 bar**

Contents of Packaging

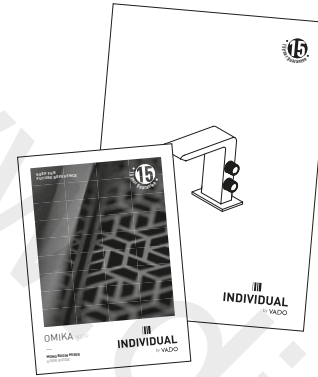

Installation guide &
User manual

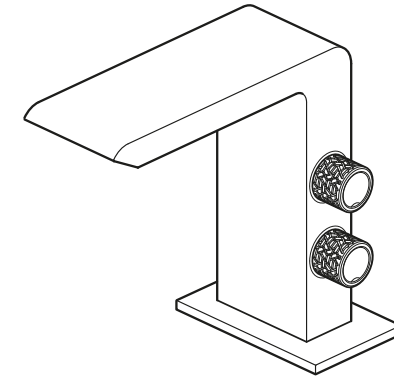

Valve body

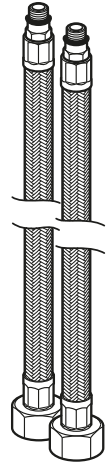

Flexible hoses



Spacer

(For use with thin work tops up to 7mm)

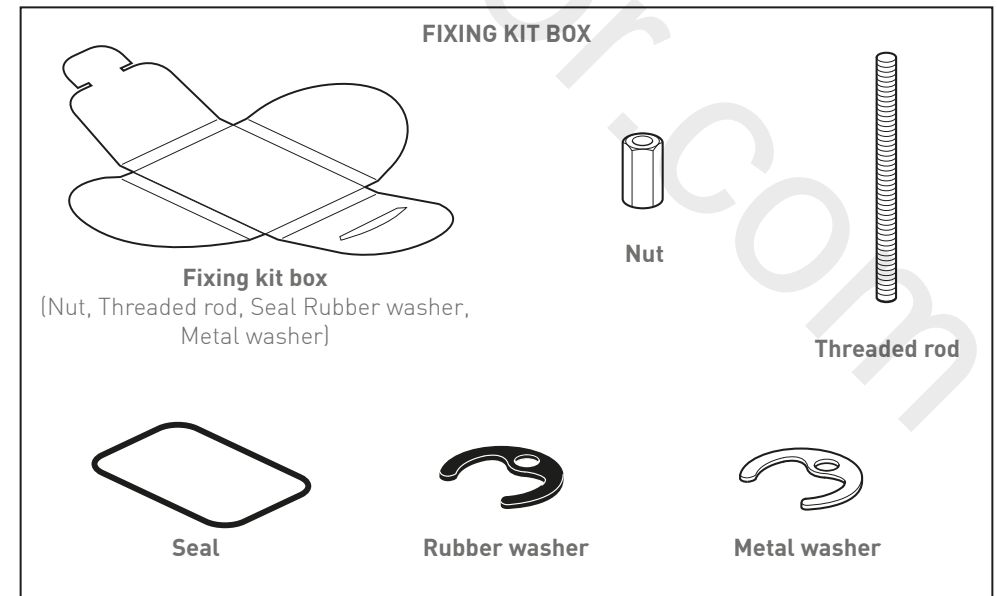

FIXING KIT BOX

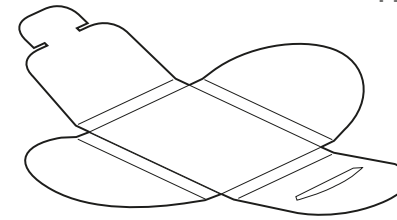

Fixing kit box

(Nut, Threaded rod, Seal Rubber washer,
Metal washer)



Nut

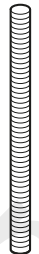

Threaded rod



Seal



Rubber washer



Metal washer

Valve dimensions

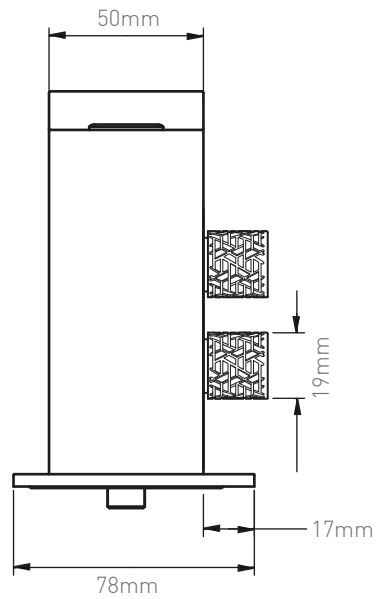
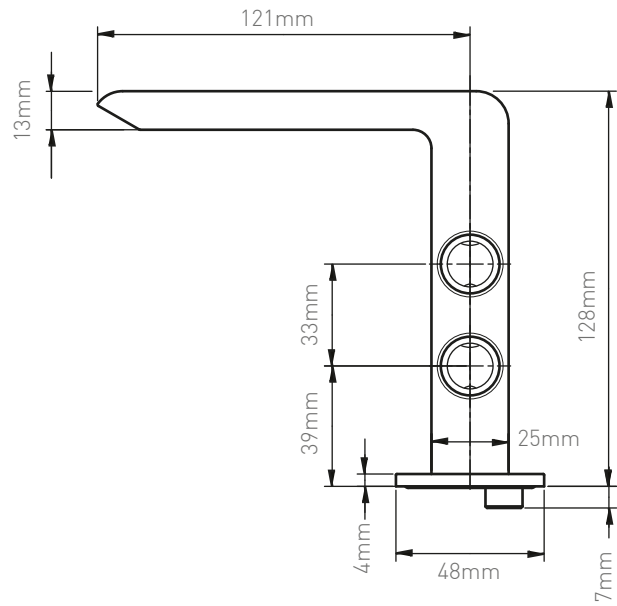

Installation - Quick guide

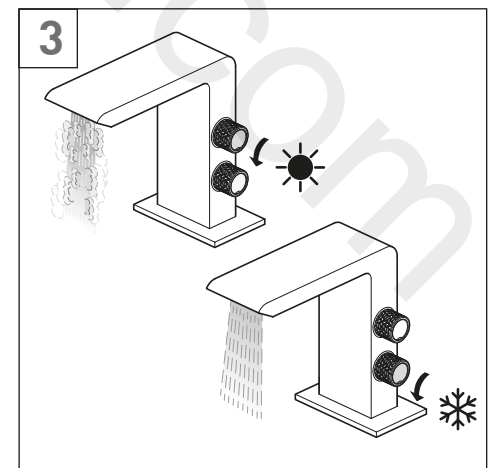
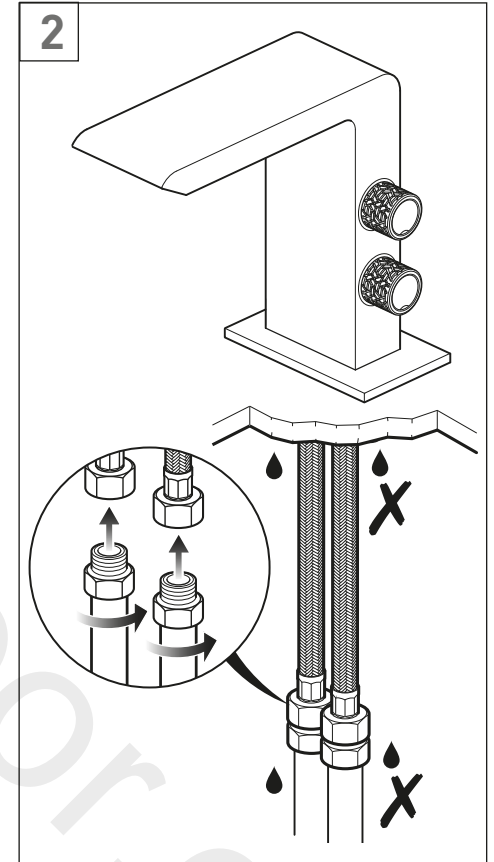
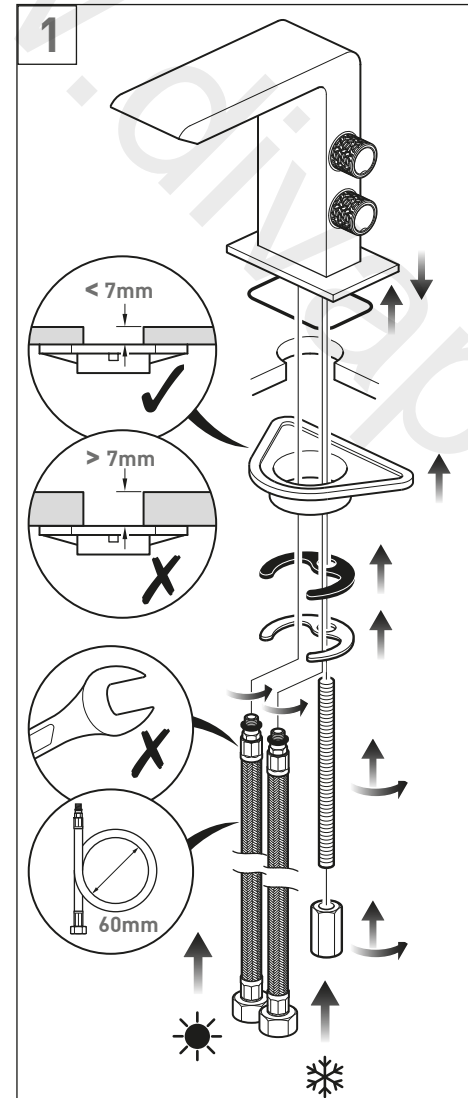
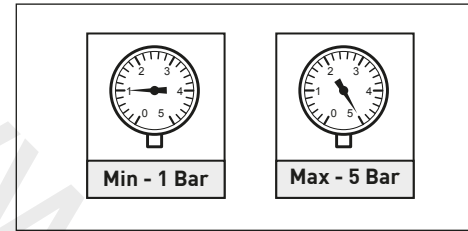

Installation

Before installing your new mixer, flush through the pipe work to ensure removal of debris, turn off the water supply.

Make sure that the seal is in position in the base of the mixer body.

Screw the threaded rod into the back hole in the base of the mixer body.

Position the mixer on the basin.

Note: If you have thin basins of 7mm or less use the spacer provided.

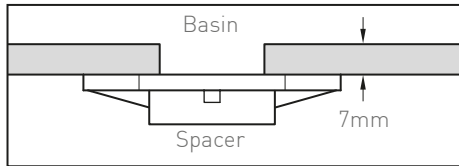

Push the hoses up through the basin hole. Screw the two flexible hoses into the hot and cold connections on the mixer body and **hand tighten only**, do not over tighten.

The hot should be connected to the left hole and the cold to the right.

Fit the rubber washer onto the threaded rod followed by the metal washer and then the lock nut. Tighten the lock nut to clamp the mixer to the basin.

CAUTION: Do not over tighten the nut as this may damage the basin.

Connect the water supply to the hoses.

The hot water should be connected to the left hose and cold to the right.

Check for leaks.

CAUTION: When installing the flexible hoses **do not** kink, or bend them more than the 60mm diameter as shown right.

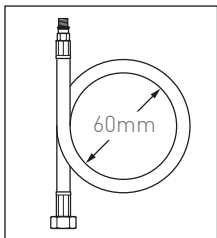

Notes:

