

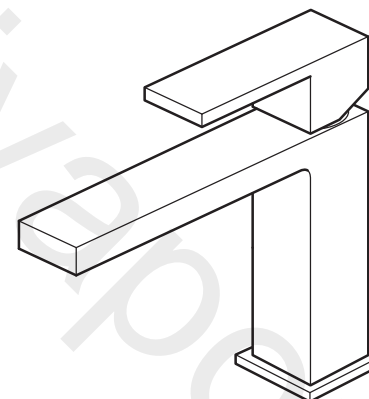

INDIVIDUAL

by VADO

This instruction booklet covers model:
IND-NOT200/SB-BLK, IND-NOT200/SB-BRG,
IND-NOT200/SB-BRN, IND-NOT200/SB-BG.



VADO
Wedmore Road, Cheddar,
Somerset, England BS27 3EB
tel 01934 744466
fax 01934 744345
www.vado.com
sales@vado.com

Version 1, 1-12-19

NOTION

Mono basin mixer

—
IND-NOT200/SB-BLK, IND-NOT200/SB-BRG,
IND-NOT200/SB-BRN, IND-NOT200/SB-BG.
INSTALLATION GUIDE

INDIVIDUAL
by VADO

Important - please read

Please read these instructions carefully before starting installation and keep for future reference.

Remove all packaging and check the product for missing parts or damage before starting installation.

Any alterations made to this product and fittings may infringe water regulations and will invalidate the guarantee.

The installation must comply with all Local/National Water Supply Authority Regulations/Byelaws and Building and Plumbing Regulations.
To be installed in accordance with BS EN806.

We strongly recommend that you use a qualified and registered plumber.

General installation

This fitting is a mixing device and therefore water supplies should be reasonably balanced.

When installed, the fitting must comply with the requirements of the Water Supply (Water Fittings) Regulations 1999 and Scottish Byelaws 2004.

For further information, contact the Water Regulations department of your local water supplier (see the WRAS website www.wras.co.uk for details) or the Water Regulations Advisory Scheme by email (info@wras.co.uk) or telephone: 01495848454.

Before making any inlet pipe connections, all supply pipes MUST be thoroughly flushed to remove debris. Failure to do so could result in damage or low flow from the mixer unit. Water Supply (Water Fittings) Regulations 1999 Schedule 2 Section 13.

The fitting of isolating valves to the inlet feeds is advised for ease of maintenance.

Please take great care when installing this mixer not to damage its surface.

Please note if installing in an enclosed environment, access should be left for servicing and maintenance. No costs relating to inadequate access can be accepted.

Operating Specifications

Operating Pressure

Minimum operating pressure **0.2 bar**

Maximum operating pressure **5 bar**

Contents of Packaging

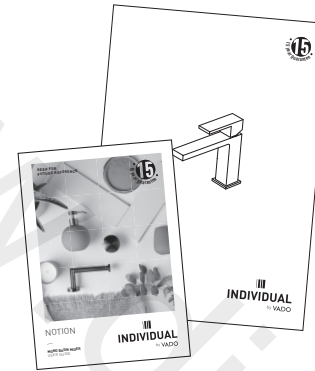

Installation guide &
User manual

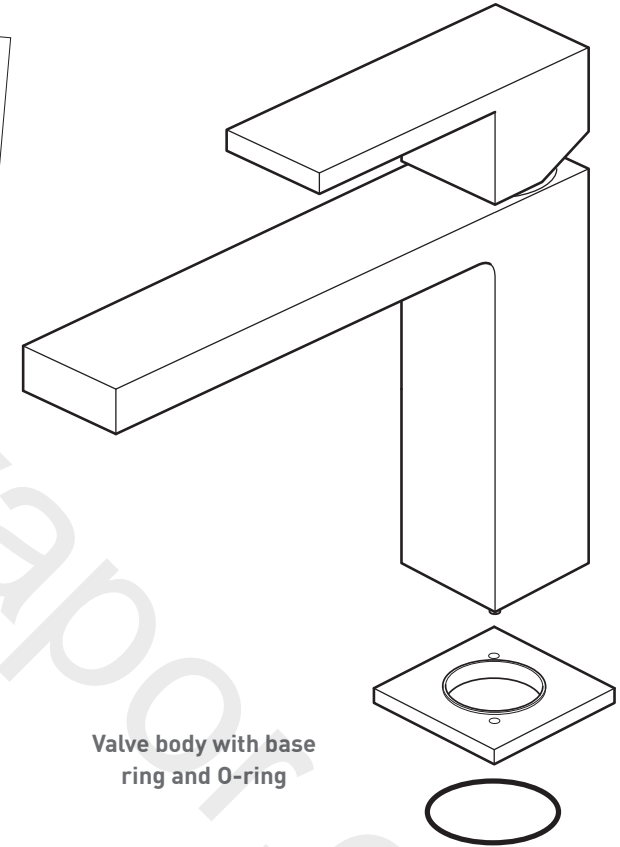

Valve body with base
ring and O-ring

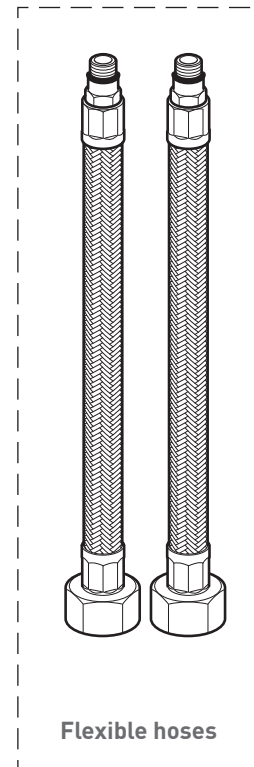

Flexible hoses

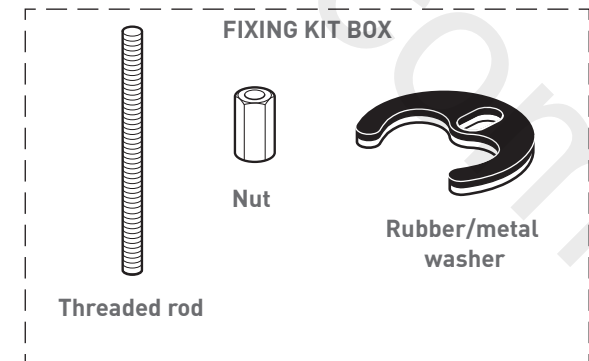

Threaded rod

FIXING KIT BOX

Nut

Rubber/metal
washer

Dimensions

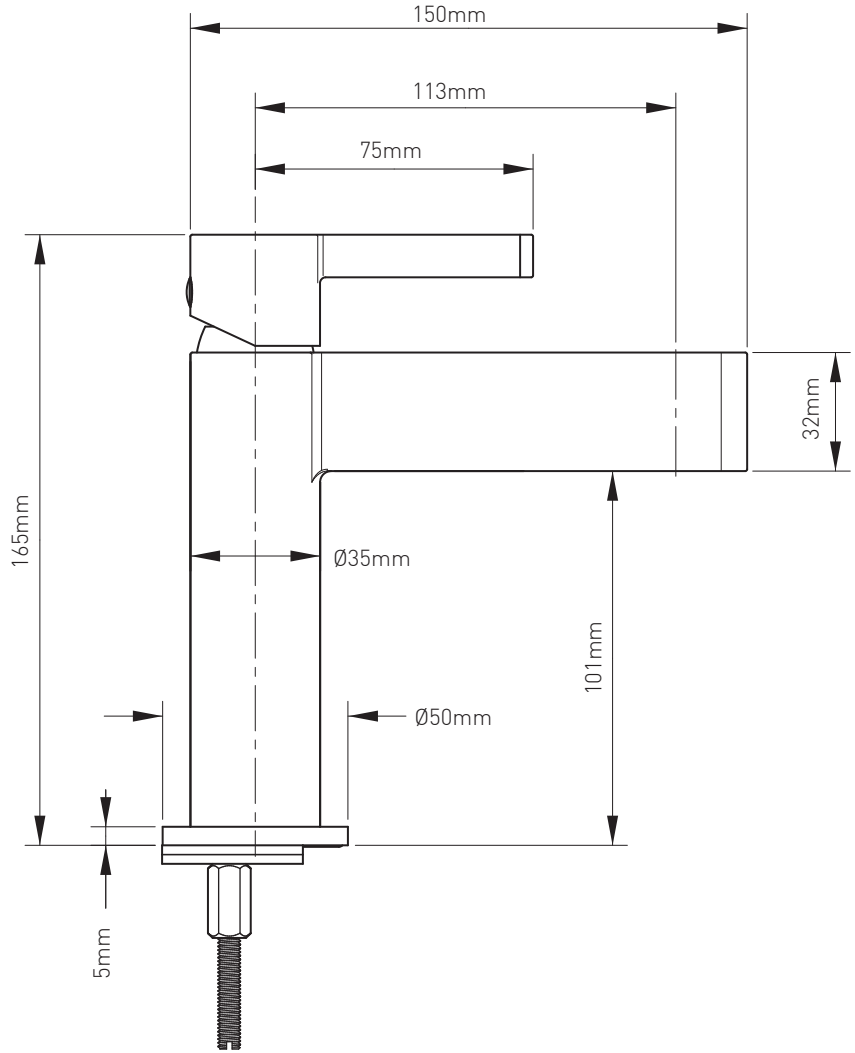

Installation - Quick guide

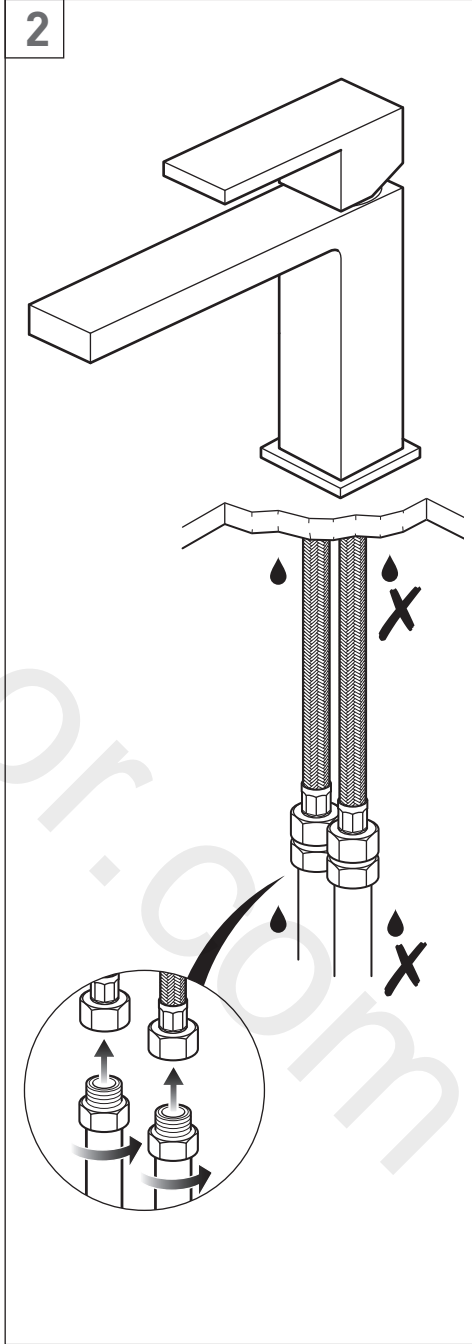
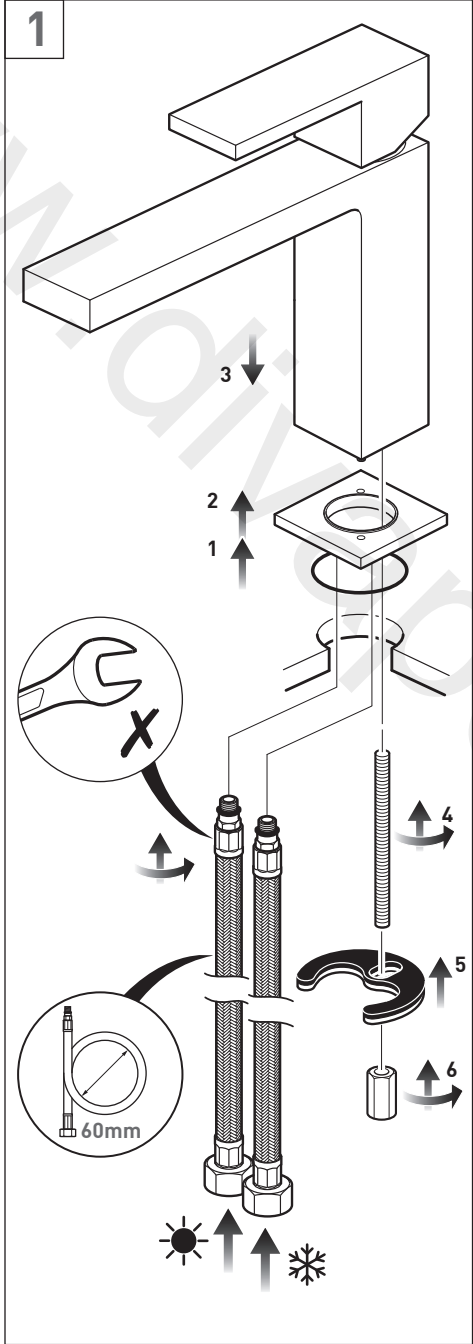

Installation

Before installing your new mixer, flush through the pipe work to ensure removal of debris, turn off the water supply.

Position the base onto the bottom of the mixer body make sure that the pins locate into the base. Ensure the O-ring is in place on the underside of the base.

Position the mixer on the basin. From the underside of the basin screw the two flexible pipes to the hot and cold connections in the mixer body, the hot should be to the left and the cold to the right, **hand tighten only**.

Screw the threaded rod into the back hole in the base of the mixer body.

Slide the rubber/metal washer onto the threaded rod, the rubber part of the washer should be on top.

Tighten the nut to clamp the mixer to the basin.

CAUTION: Do not over tighten the nut as this may damage the basin.

Connect the water supply to the inlet pipes. The hot water should be connected to the left pipe and cold to the right.

CAUTION: When installing the flexible hoses **do not** kink, or bend them more than the 60mm diameter as shown right.

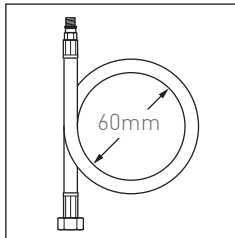

Notes:

