

## Customer/technical services

For any technical or installation queries please contact VADO on 01934 745163.

## Guarantee

This product is guaranteed against manufacturing defects from the date of purchase until the expiry of the relevant guarantee period shown below.

### The guarantee is only valid if:-

1. The product has been installed, used and maintained in accordance with Vado's instructions and subjected to normal use only.
2. The defect is not due to use of an unsuitable or inadequate water or power supply.
3. The defect is not due to accident, misuse, neglect or repair other than by Vado or Vado authorised agents or damage caused by foreign objects or substances.
4. We have received from you the completed Guarantee Registration Form. Vado accepts no responsibility for any forms lost in the post and returns by registered means is therefore recommended.

Under this guarantee (which is non-transferable) Vado will, at its option, repair or replace free of charge any product (or replacement part) found to be defective. The guarantee does not extend to any consequential loss or damage. After repair or replacement the relevant guarantee period will be calculated from the original date of purchase.

### The relevant guarantee periods are:-

1. Twelve years on chrome finish products.
2. Six years on Vado Identity products.
3. Three years on all other products with the exception of Stuart Turner Pumps which carry a 2 year Guarantee on Monsoon Range and 1 Year Guarantee on Showermate Range.

All claims under the guarantee must be submitted in writing to the person who supplied the product to you and must be received no later than the last day of the relevant guarantee period. All claims must be accompanied by proof of purchase (sales receipt or delivery note).

Vado operates a policy of continuous product development and therefore reserves the right to change the product, packaging and documentation specifications without notice.

This guarantee is in addition to and does not affect your statutory rights as a consumer.

### VADO

Wedmore Road, Cheddar, Somerset, England BS27 3EB  
tel 01934 744466 fax 01934 744345  
technical@vado.com  
www.vado.com

### GUARANTEE REGISTRATION

NAME				
ADDRESS				
	POSTCODE			
RETAILER				
ADDRESS				
	POSTCODE			
PURCHASE DATE	ARTICLE NUMBER	(SEE BOX)		
PRODUCT DESCRIPTION				
WHO INSTALLED THE PRODUCT?	RETAILER	PLUMBER	BUILDER	SELF
FOR VADO USE				



## Installation & maintenance instructions

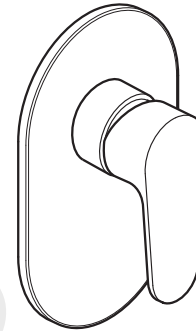

Ascent

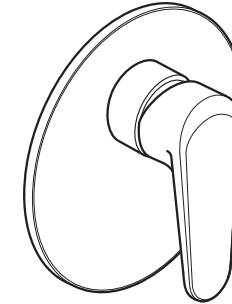

Chelsea

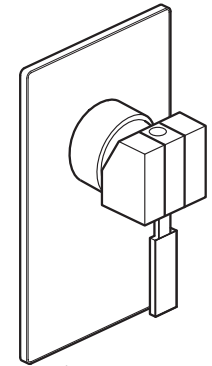

Instinct

Ascent Chelsea Edit Instinct Ion Kovera Life  
Magma Matrix Notion Origins Phase Photon  
Sense Soho Synergie Té Zoo VIE

Wall mounted concealed single lever shower mixer

Please leave these instructions with the customer

## Important - please read

Please read these instructions carefully before starting installation and keep for future reference.

Remove all packaging and check the product for missing parts or damage before starting installation.

Any alterations made to this product and fittings may infringe water regulations and will invalidate the guarantee.

The installation must comply with all Local/National Water Supply Authority Regulations/Byelaws and Building and Plumbing Regulations.

We strongly recommend that you use a qualified and registered plumber.

## General installation

These fittings are mixing devices and therefore water supplies must be reasonably balanced.

Where connections are made to the mains cold water supply, WRC approved single check valves must be fitted to both hot and cold inlets. This is a stated requirement of Water Supply (Water Fittings) Regulations 1999 Schedule 2, Section 15.

Before making any inlet pipe connections, all supply pipes MUST be thoroughly flushed to remove debris. Failure to do so could result in damage or low flow from the mixer unit. Water Supply (Water Fittings) Regulations 1999 Schedule 2 Section 13.

The fitting of isolating valves to the inlet feeds is advised for ease of maintenance.

Please take great care when installing this mixer not to damage its surface.

Please note if installing in an enclosed environment, access should be left for servicing and maintenance. No costs relating to inadequate access can be accepted.

## Care of the mixer

Our products are finished to the highest standard and due care needs to be taken to ensure their looks are retained.

We recommend cleaning all products with a soft damp cloth ONLY and advise strongly against the use of ALL cleaning products i.e. powders and liquids.

If the above instructions are not followed this will invalidate your guarantee in the event of a problem occurring.

## EDI-145 Installation

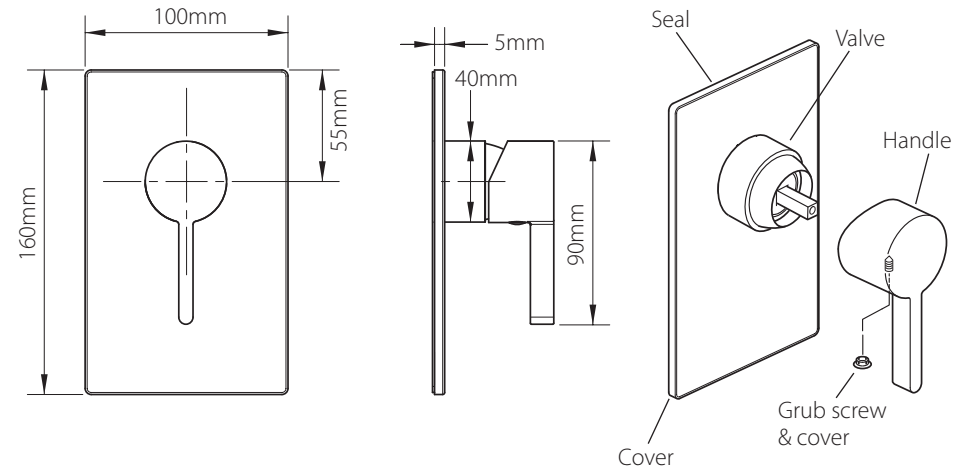

Remove the backing paper from the seal on the back of the cover. Slide the cover over the valve, push onto the wall until it makes contact.

Carefully slide the control handle onto the valve and secure in position with the grub screw within the handle using the hexagonal key supplied, replace the screw cover.

## Operation

**Note:** For illustrative purposes only the Ascent version is shown.

The same operation applies to all the other shower valves.

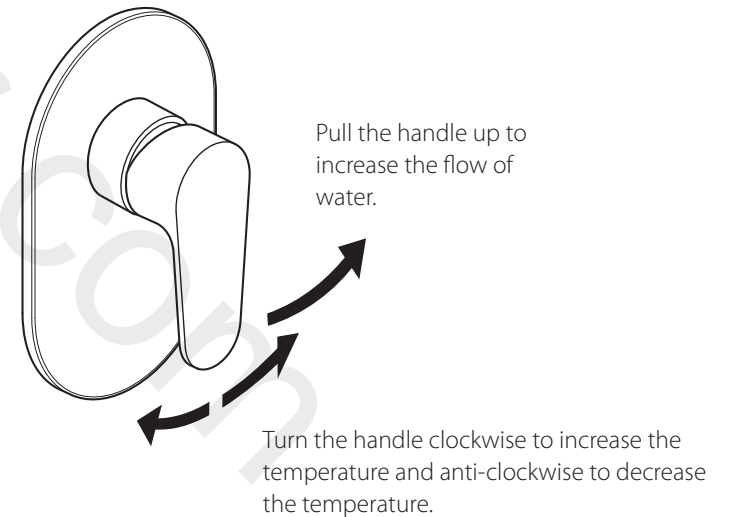

## VIE-145 installation

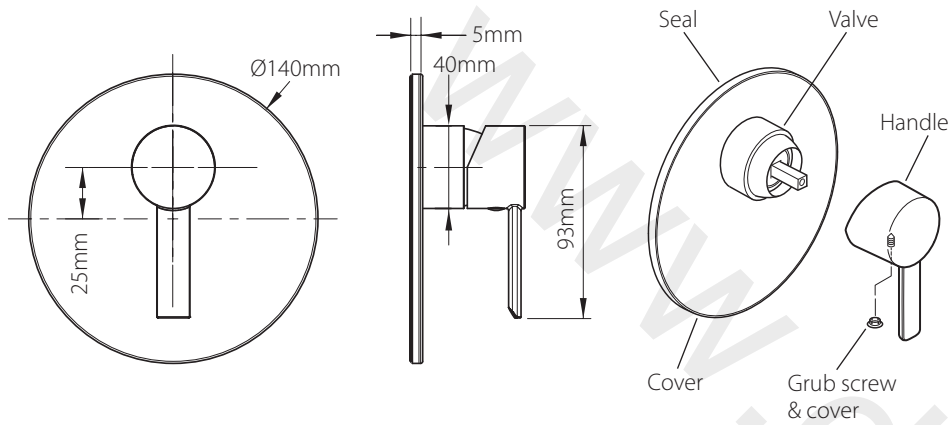

Remove the backing paper from the seal on the back of the cover. Slide the cover over the valve, push onto the wall until it makes contact.

Carefully slide the control handle onto the valve and secure in position with the grub screw within the handle using the hexagonal key supplied, replace the screw cover.

## VIE-245 Installation

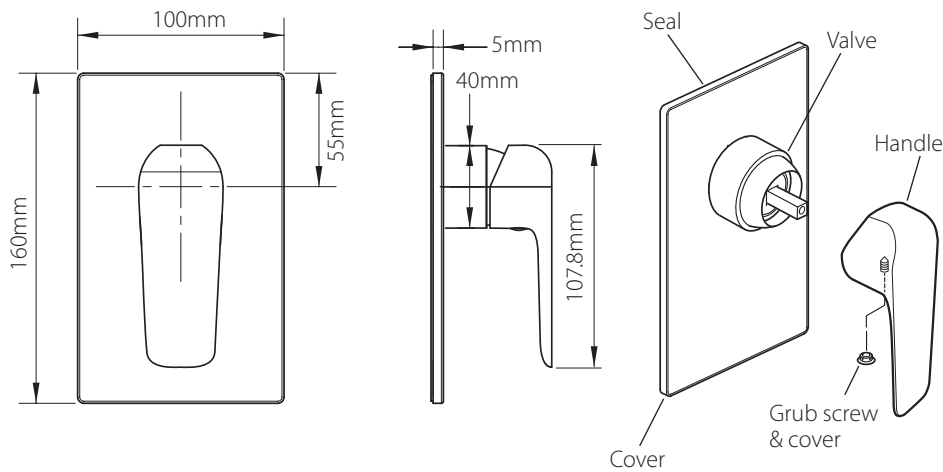

Remove the backing paper from the seal on the back of the cover. Slide the cover over the valve, push onto the wall until it makes contact.

Carefully slide the control handle onto the valve and secure in position with the grub screw within the handle using the hexagonal key supplied, replace the screw cover.

## Dimensions - valve

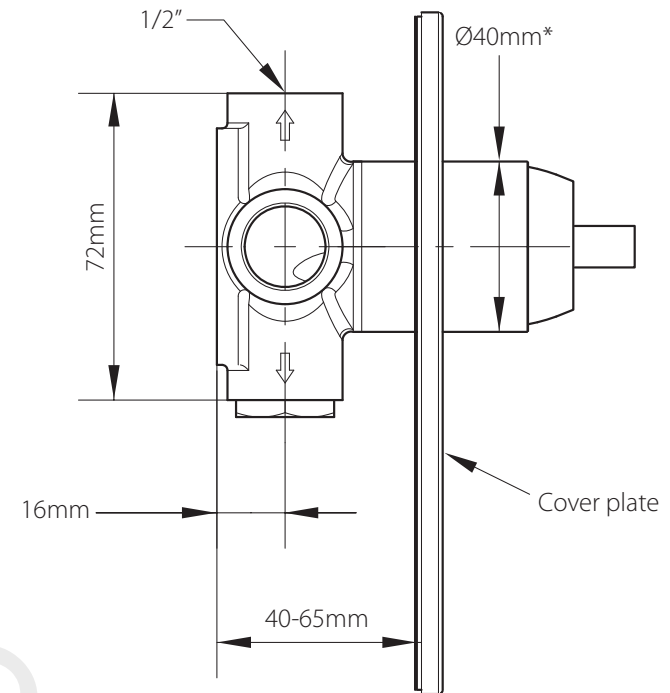

\* This dimension changes to 50mm for the Soho only.

## Operating Specifications

### Operating Pressure

Minimum operating pressure 0.5 bar (1.5 bar if used as a bath fill).

Maximum operating pressure 5 bar

## Installation - valve

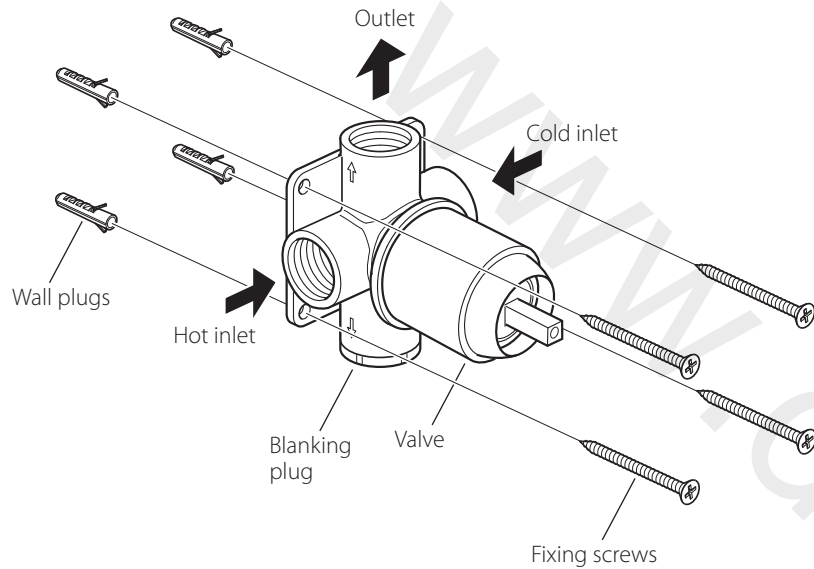

Before installing your new mixer, flush through the pipe work to ensure removal of debris, turn off the water supply.

**Warning!** Please check for any hidden cables and pipes before drilling holes in the wall. During installation protect the outer parts by leaving the plastic protective carton on the valve to avoid damage to plated surfaces.

The valve must be set into the wall by 40-65mm (see dimension page). If you are fitting the valve to a partition wall or a wall of particularly soft substrate you will need specialist fixings.

Select the position for the shower valve and offer the shower valve to the wall, mark the 4 fixing points with a suitable pencil. Remove the shower valve from the wall, drill the holes to a suitable depth for the wall plugs and secure with the supplied screws.

Make all connections to the valve. Connect hot supply to left inlet of the valve and cold supply to right inlet. Connect the outlet (top) to the shower.

For installation of the cover and handle see pages 5-13 for your relevant shower valve.

## Zoo (square) Installation

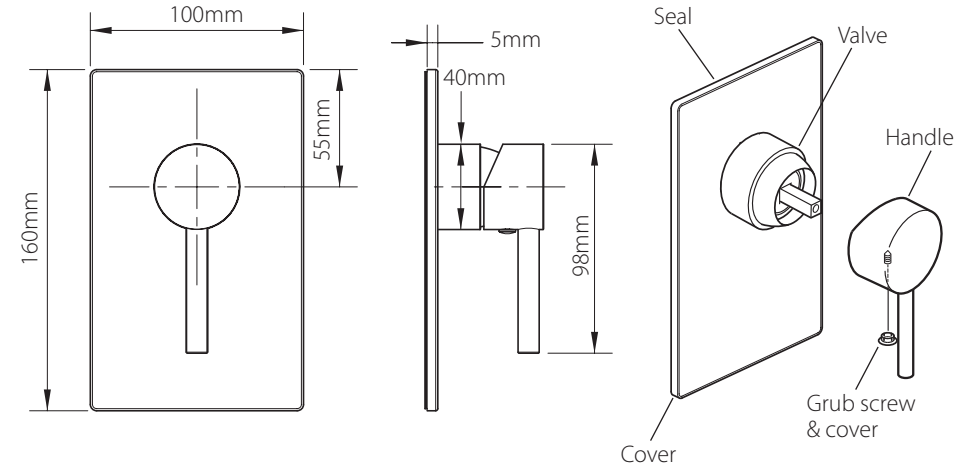

Remove the backing paper from the seal on the back of the cover. Slide the cover over the valve, push onto the wall until it makes contact.

Carefully slide the control handle onto the valve and secure in position with the grub screw within the handle using the hexagonal key supplied, replace the screw cover.

## Kovera installation

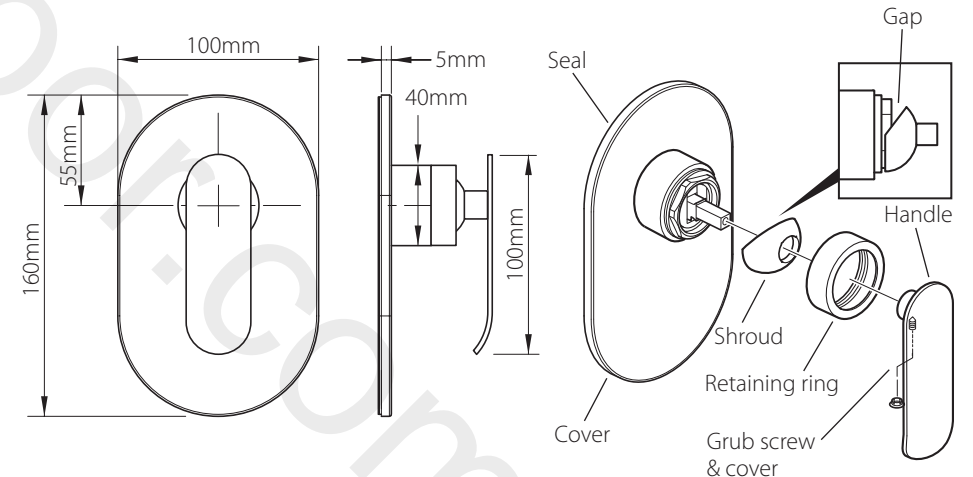

Remove the backing paper from the seal on the back of the cover. Slide the cover over the valve, push onto the wall until it makes contact.

Carefully slide the shroud onto the valve making sure there is a gap at the top, attach the retaining ring at an angle. Push on the control handle and secure in position with the grub screw within the handle using the hexagonal key supplied, replace the screw cover.

### Té installation

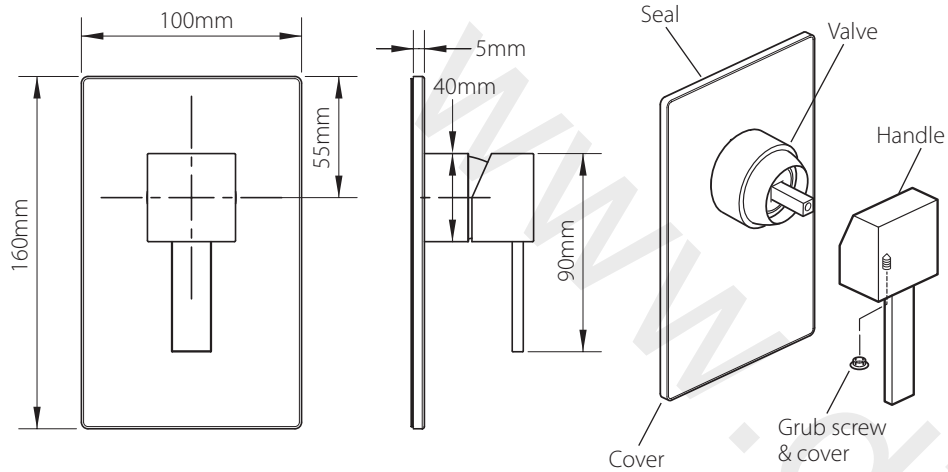

Remove the backing paper from the seal on the back of the cover. Slide the cover over the valve, push onto the wall until it makes contact.

Carefully slide the control handle onto the valve and secure in position with the grub screw within the handle using the hexagonal key supplied, replace the screw cover.

### Ascent installation

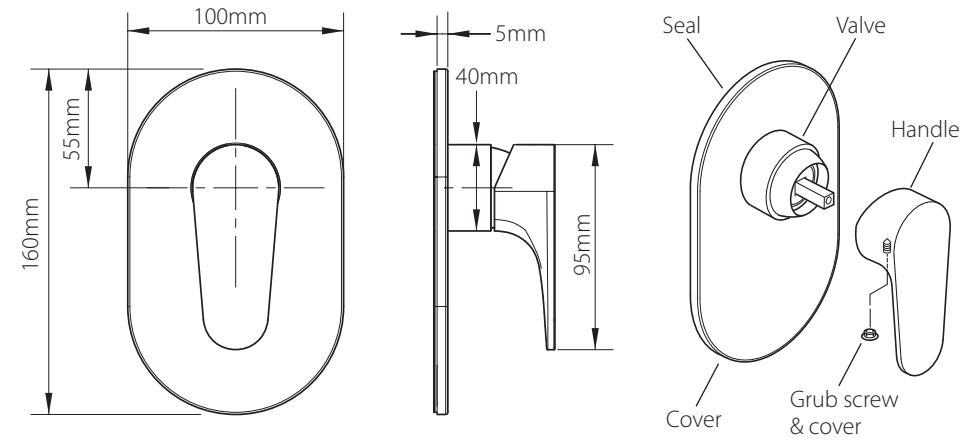

Remove the backing paper from the seal on the back of the cover. Slide the cover over the valve, push onto the wall until it makes contact.

Carefully slide the control handle onto the valve and secure in position with the grub screw within the handle using the hexagonal key supplied, replace the screw cover.

### Zoo (round) installation

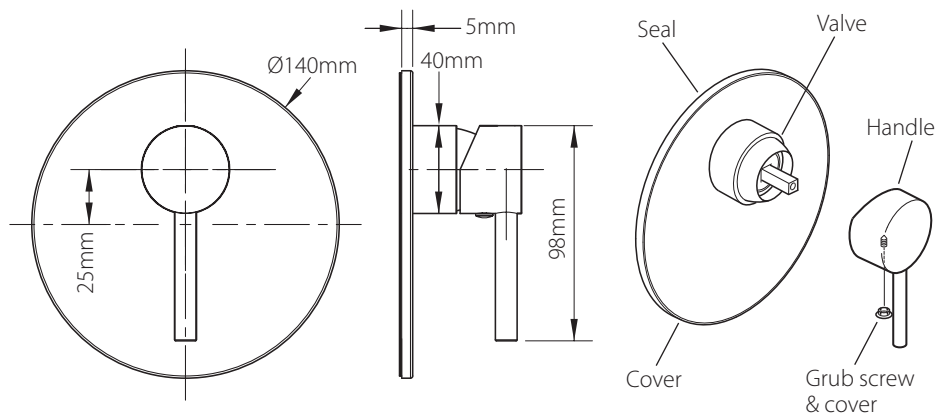

Remove the backing paper from the seal on the back of the cover. Slide the cover over the valve, push onto the wall until it makes contact.

Carefully slide the control handle onto the valve and secure in position with the grub screw within the handle using the hexagonal key supplied, replace the screw cover.

### Chelsea installation

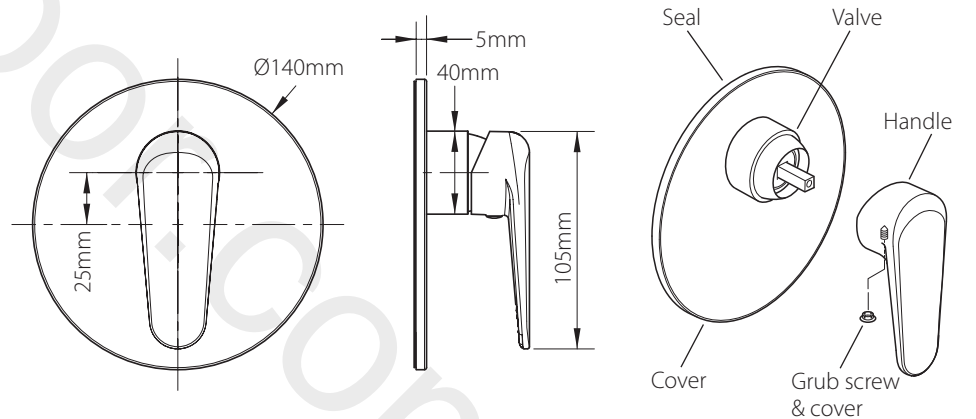

Remove the backing paper from the seal on the back of the cover. Slide the cover over the valve, push onto the wall until it makes contact.

Carefully slide the control handle onto the valve and secure in position with the grub screw within the handle using the hexagonal key supplied, replace the screw cover.

### Instinct installation

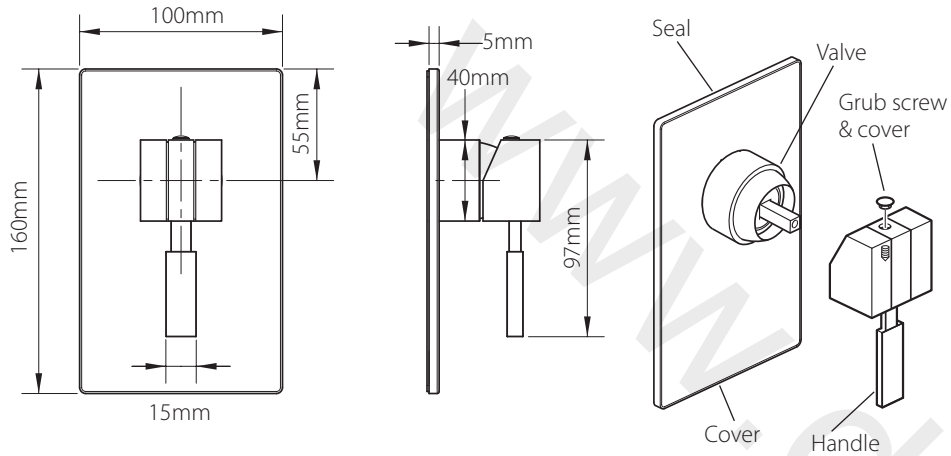

Remove the backing paper from the seal on the back of the cover. Slide the cover over the valve, push onto the wall until it makes contact.

Carefully slide the control handle onto the valve and secure in position with the grub screw within the handle using the hexagonal key supplied, replace the screw cover.

### Soho installation

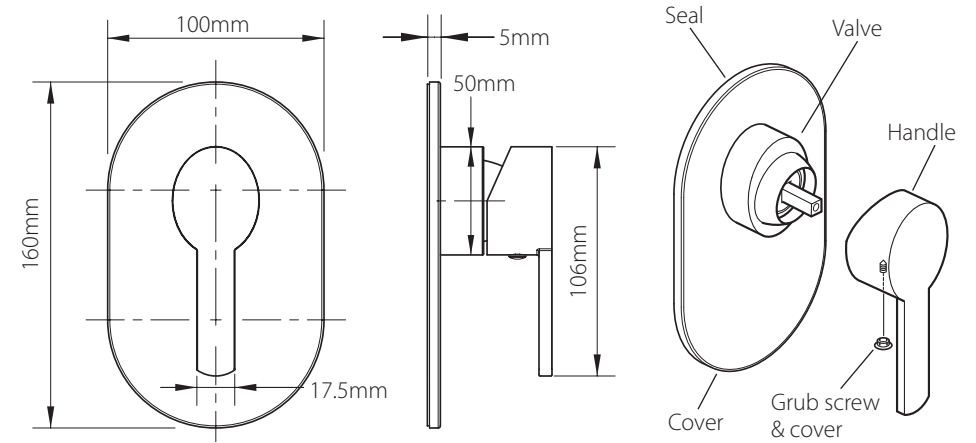

Remove the backing paper from the seal on the back of the cover. Slide the cover over the valve, push onto the wall until it makes contact.

Carefully slide the control handle onto the valve and secure in position with the grub screw within the handle using the hexagonal key supplied, replace the screw cover.

### Ion installation

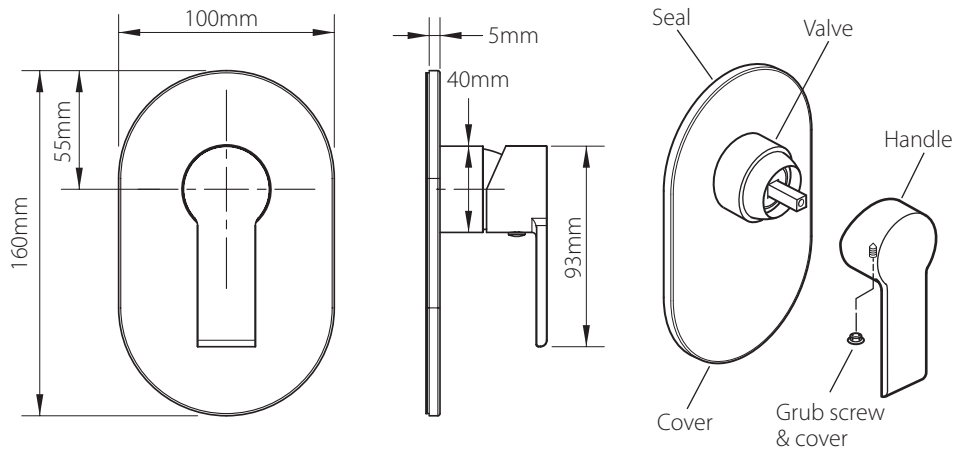

Remove the backing paper from the seal on the back of the cover. Slide the cover over the valve, push onto the wall until it makes contact.

Carefully slide the control handle onto the valve and secure in position with the grub screw within the handle using the hexagonal key supplied, replace the screw cover.

### Synergie installation

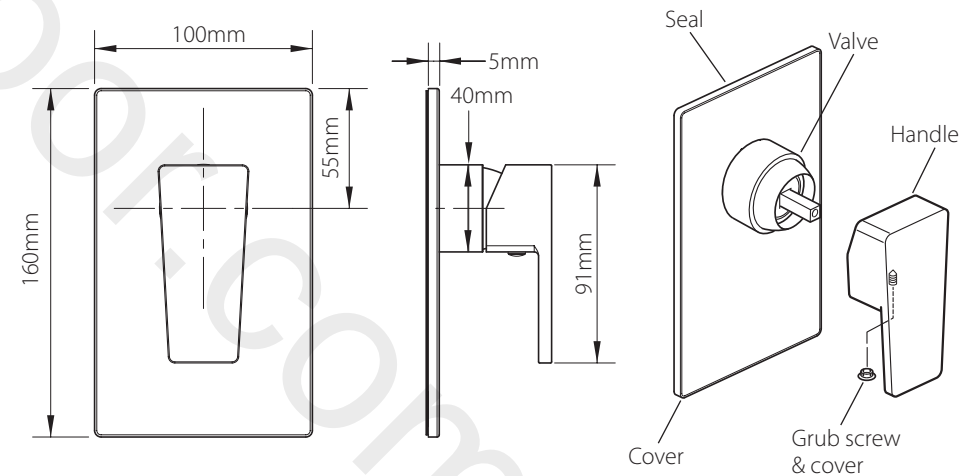

Remove the backing paper from the seal on the back of the cover. Slide the cover over the valve, push onto the wall until it makes contact.

Carefully slide the control handle onto the valve and secure in position with the grub screw within the handle using the hexagonal key supplied, replace the screw cover.

### Photon installation

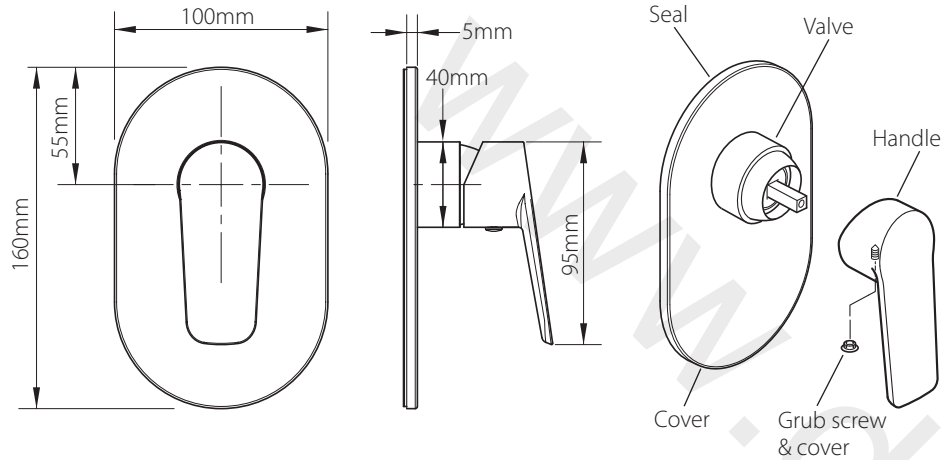

Remove the backing paper from the seal on the back of the cover. Slide the cover over the valve, push onto the wall until it makes contact.

Carefully slide the control handle onto the valve and secure in position with the grub screw within the handle using the hexagonal key supplied, replace the screw cover.

### Life installation

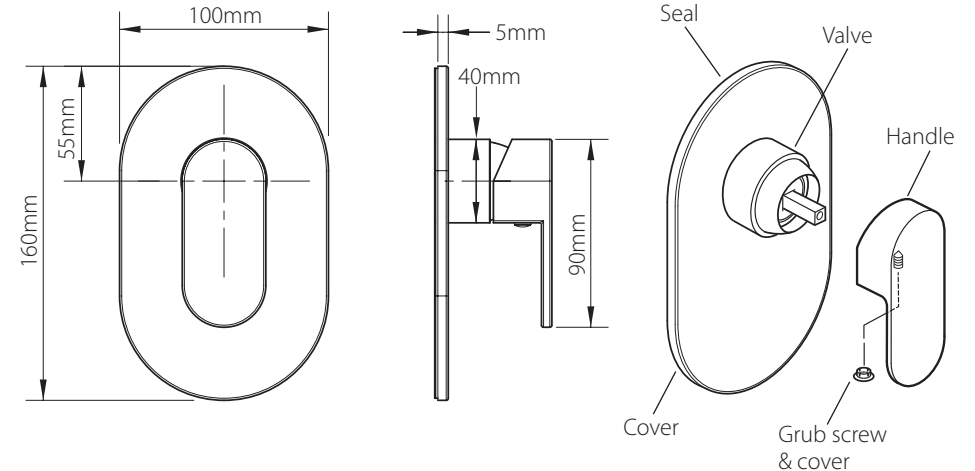

Remove the backing paper from the seal on the back of the cover. Slide the cover over the valve, push onto the wall until it makes contact.

Carefully slide the control handle onto the valve and secure in position with the grub screw within the handle using the hexagonal key supplied, replace the screw cover.

### Sense installation

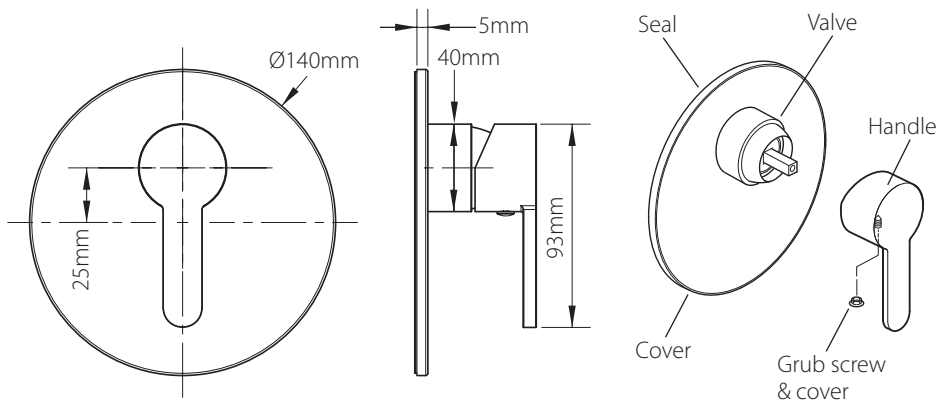

Remove the backing paper from the seal on the back of the cover. Slide the cover over the valve, push onto the wall until it makes contact.

Carefully slide the control handle onto the valve and secure in position with the grub screw within the handle using the hexagonal key supplied, replace the screw cover.

### Magma installation

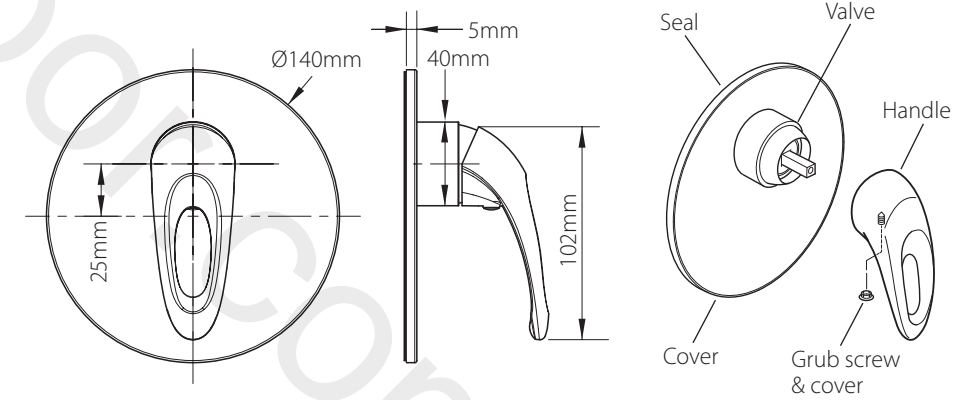

Remove the backing paper from the seal on the back of the cover. Slide the cover over the valve, push onto the wall until it makes contact.

Carefully slide the control handle onto the valve and secure in position with the grub screw within the handle using the hexagonal key supplied, replace the screw cover.

## Matrix installation

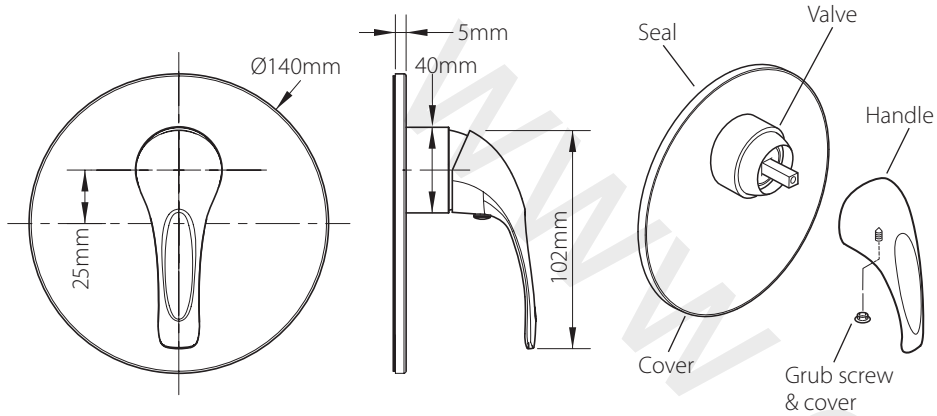

Remove the backing paper from the seal on the back of the cover. Slide the cover over the valve, push onto the wall until it makes contact.

Carefully slide the control handle onto the valve and secure in position with the grub screw within the handle using the hexagonal key supplied, replace the screw cover.

## Origins installation

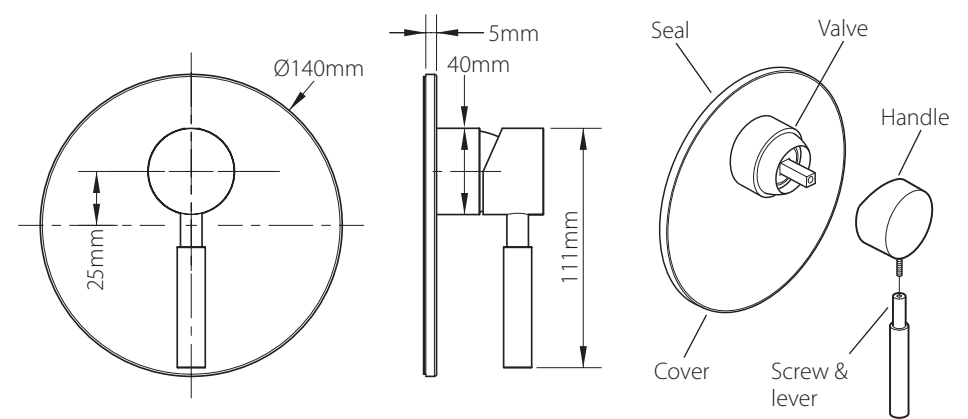

Remove the backing paper from the seal on the back of the cover. Slide the cover over the valve, push onto the wall until it makes contact.

Carefully slide the control handle onto the valve and secure in position with the grub screw under the handle using the hexagonal key supplied, screw the lever onto the handle.

## Notion installation

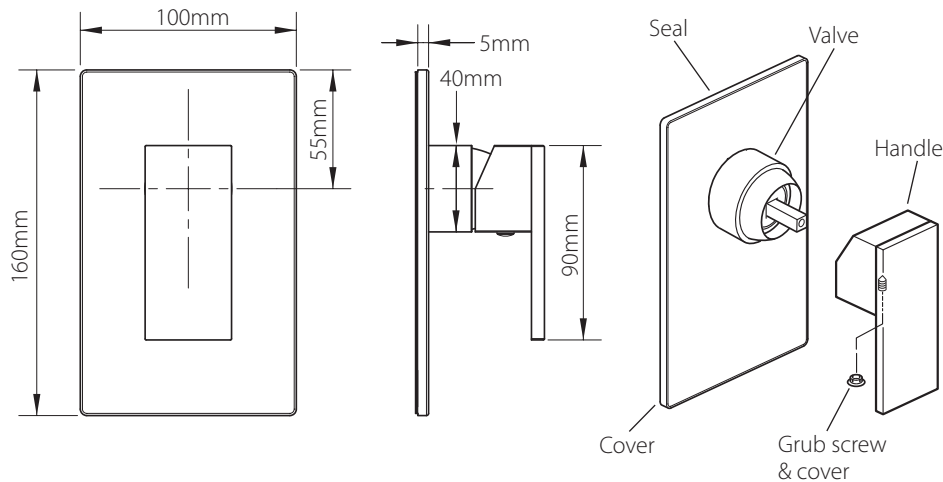

Remove the backing paper from the seal on the back of the cover. Slide the cover over the valve, push onto the wall until it makes contact.

Carefully slide the control handle onto the valve and secure in position with the grub screw within the handle using the hexagonal key supplied, replace the screw cover.

## Phase installation

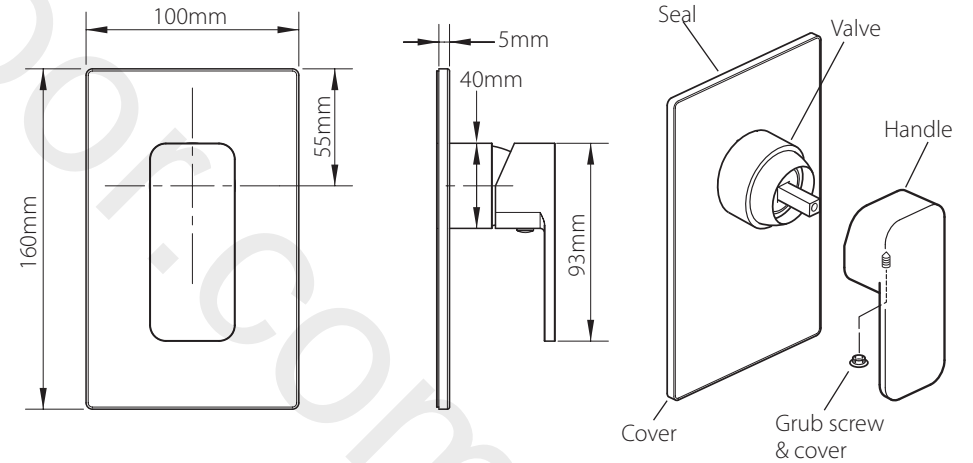

Remove the backing paper from the seal on the back of the cover. Slide the cover over the valve, push onto the wall until it makes contact.

Carefully slide the control handle onto the valve and secure in position with the grub screw within the handle using the hexagonal key supplied, replace the screw cover.