

Guarantee

All VADO products come with a 2 year guarantee as standard. Within this guarantee period VADO will provide replacement parts and any labour **[SEE NOTE 1]** needed to complete the product repair.

This standard guarantee may be extended by registering your product to give the following guarantee periods, once registered:

Brassware products from the Individual by VADO collection have a 15 year guarantee (2 years parts and labour plus 13 years parts only).

VADO Sensori SmartTouch and SmartDial products have a 5 year guarantee (parts and labour).

VADO Identity and i-tech products have a 5 year guarantee (2 year parts and labour plus 3 years parts only).

All other VADO products have a 3 year guarantee (2 years parts and labour plus 1 year parts only)

[SEE NOTE 2].

Guarantee Conditions

Our products are guaranteed against manufacturing defects from the date of purchase until the expiry of the relevant guarantee period shown above.

The guarantee is only valid if:

- The product has been installed, used and maintained in accordance with VADO's instructions and subjected to normal use only.
- The defect is not due to use of an unsuitable or inadequate water or power supply.
- The defect is not due to accident, misuse, neglect or incorrect/inappropriate repair (other than by VADO or VADO authorised agents) or damage caused by foreign objects or substances.
- The extended guarantee is only available if you have completed the Guarantee Registration Process.

This can be done via the VADO website or via phone to our aftersales team.

Registration must be completed within 6 months from date of purchase.

Under the extended guarantee period VADO will, at its option, offer to supply any replacement product (or component part) assessed to be defective **[SEE NOTE 3]**.

The guarantee (whether standard or extended) is non-transferable to any subsequent owner.

All claims under the guarantee should be notified in the first instance to our Aftersales department, contact details below, this must be done no later than the last day of the relevant guarantee period.

All claims must be accompanied by proof of purchase (sales receipt or delivery note) from an official VADO dealer.

The guarantee does not extend to any consequential loss or damage.

After repair or replacement, the relevant guarantee period will be calculated from the original date of purchase.

VADO operates a policy of continuous product development and therefore reserves the right to change the product, packaging and documentation specifications without notice. E&OE.

NOTES:

[1] Labour via our engineer network is only available in the UK. Attendance by a VADO engineer or sub-contract engineer will be under our standard terms and conditions.

[2] VADO spare parts and shower hoses are under a parts only guarantee.

[3] VADO reserves the right to charge in advance for a product (or replacement part) pending collection and investigation (at VADO expense) to confirm a defect is due to a manufacturing issue.

If a defect is found the charge will be refunded or cancelled.

This guarantee is in addition to and does not affect your statutory rights as a consumer.

Tel: 01934 745163

Email: aftersales@vado.com



INDIVIDUAL
THERMOSTATIC SHOWER VALVE WITH
ADJUSTABLE RIGID RISER
USER GUIDE

INDIVIDUAL
by VADO

Welcome

Thank you for selecting Individual by VADO.

Each timeless finish has been tailored to inspire your individual style, ready for you to create a contemporary look that will stand the test of time.

Coupled with our leading 15 year guarantee, this premium product has passed through stringent quality assurance processes to allow you to complete your look with confidence.

Our outstanding customer service, large scale development support and prestigious project history has ensured a globally trusted reputation. For any technical or operation queries, please contact our experienced Aftersales team on 01934 745 163.

Vado, Wedmore Road, Cheddar, Somerset, England BS27 3EB
tel 01934 744466 fax 01934 744345
aftersales@vado.com
www.vado.com

Maintenance

7. Reassemble the cartridge into the body, then place the spacer and plastic stop ring onto the cartridge with the step at the 3 o'clock position.

8. Turn on the water supply.

9. Check the water temperature to ensure correct commissioning.

See page 6 of this guide or Vado.com for commissioning.

10. Ensure that the step on the stop ring is at 3 o'clock, replace the handle making sure that the pin (within the handle) is against the step.

Maintenance

Thermostatic cartridge

To clean the filters, you must first remove the cartridge from the housing.

Removing the Cartridge:

1. Check water has been isolated.
2. Remove the handle. Remove the stop ring and spacer by carefully pulling away from the valve.
3. Unscrew the grub screw on the underside of the body and pull out the cartridge.
4. Clean filters by rinsing them under running water to remove any debris.
5. If there is limescale deposits then it is recommended to immerse the cartridge for a few minutes in 50% white vinegar + 50% hot water, brush the filters gently and then rinse under running water to clean all particles. If this is not effective, a replacement cartridge should be fitted.
6. Before reassembling the cartridge, clean its housing with a wet cloth and grease the O-rings using a suitable silicone grease.

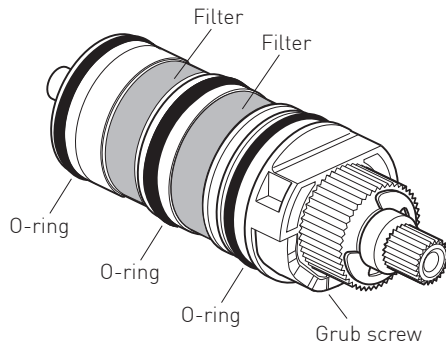

Operation - riser rail

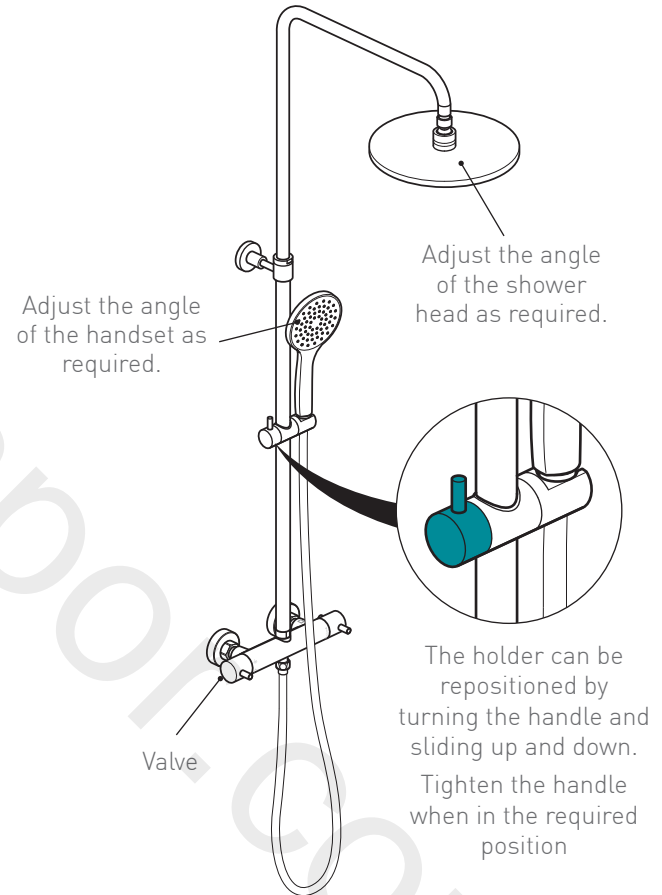

Operation - valve

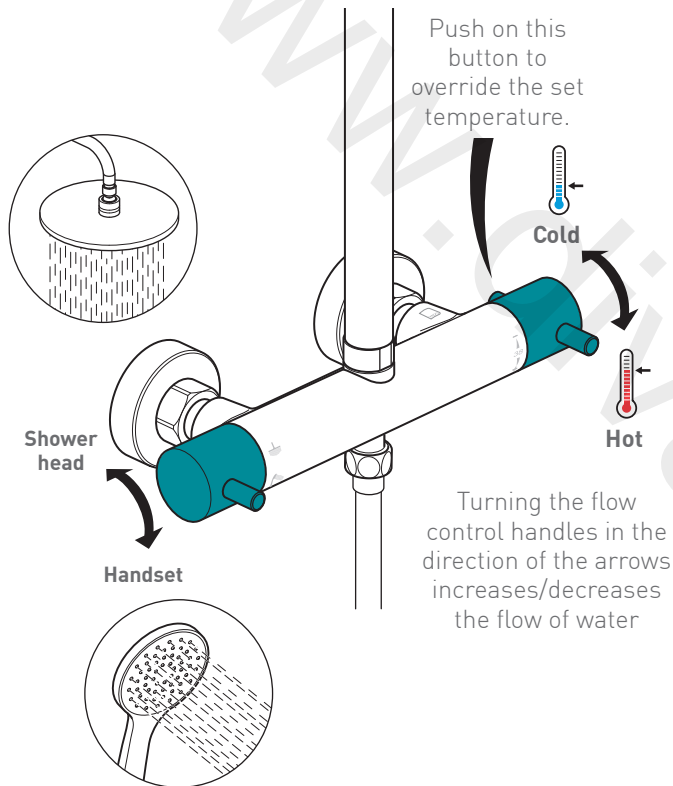

Turning the handle in the direction of the arrows diverts the flow of water between the shower head and handset

Maintenance

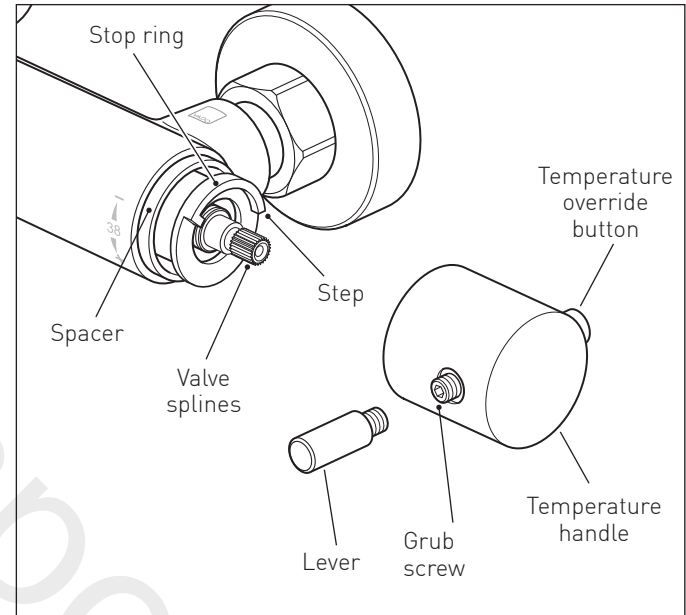

This thermostatic valve is fitted with a double filtering facility. Filters are fitted on the water inlets and on the thermostatic cartridge.

Depending on the water quality, filters may become dirty, causing reduced flow and inefficient working of the valve.

Inlet filters

Check water has been isolated. Undo both locking nuts at the back of the valve and remove from the wall. Pull out the filter/washer, rinse in water to remove the dirt, and then soak them in vinegar or descaling agent.

Maintenance

We advise that the below is carried out annually as failure to do so may result in invalidation of warranty.

Isolating the thermostatic valve

IMPORTANT: Please see the below procedure for isolating the thermostatic valve.

1. Isolate the incoming hot and cold water to the valve.
2. Turn shower valve on (left handle) to check isolation, please ensure that your body/hands are not under the flow of water as there is a potential for delivery of hot water.
3. Remove temperature control handle and temperature stop ring (essential).
4. With shower in the on position, replace temperature handle on thermostatic Valve (ensure temp stop has been removed).
5. Turn temp handle fully anti clockwise until stop point is reached and can be turned no further , please ensure that your body/hands are not under the flow of water as there is potential for delivery of hot water if isolation has been unsuccessful.
6. Turn temperature handle fully clockwise until resistance is felt.
7. If there is no flow of water coming from the outlet during both points 5 and 6 isolation has been successful, you may now remove and maintain the cartridge.
8. If at any of the above point's water continues to flow please isolate at an alternative point within the system for both hot and cold and repeat points 2-8.

Cleaning instructions:

The physical vapor deposition coating on this product is finished to the highest standard. Due care needs to be taken to ensure the appearance is retained. We recommend cleaning all products with a soft damp cloth ONLY and advise strongly against the use of all aggressive/corrosive cleaning products i.e. powders and liquids. If these instructions are not followed, this may invalidate your guarantee in the event of a problem occurring.

Commissioning

The valve has been factory set under balance pressures and hot water supply at 65°C. When your specific operating conditions are significantly different from the above, the temperature of the water may vary from the setting.

When the difference is too great, you can adjust the calibration of the valve to suit individual requirements of the installation:

1. Check the temperature of the water being delivered from the outlet with a thermometer.

Note: temperature readings should be taken at normal flow rate after allowing for the system to stabilise.

2. If the temperature is not 38°C proceed to reset the calibration as follows.

Remove the handle by unscrewing the lever, releasing the grub screw and pulling off the handle.

Ensure the step on the stop ring is located at 3 o'clock. Do not remove the plastic stop ring. Turn the spline of the thermostatic valve clockwise to decrease the temperature and anti-clockwise to increase the temperature until 38°C is achieved at outlet.

Note: the sensing part of the thermometer probe must be fully submerged in the water that is to be tested.

Replace the handle making sure that the pin (within the handle) is against the step.

Once the handle has been attached ensure the temperature does not exceed 46°C when turned entirely anti-clockwise.

Your valve setting is now commissioned.

Commissioning

