

matki | SHOWERING

ELIXIR CONCEALED THERMOSTATIC SHOWER BLADE DESIGN EX20/EX28

INSTALLATION

PARTS LIST

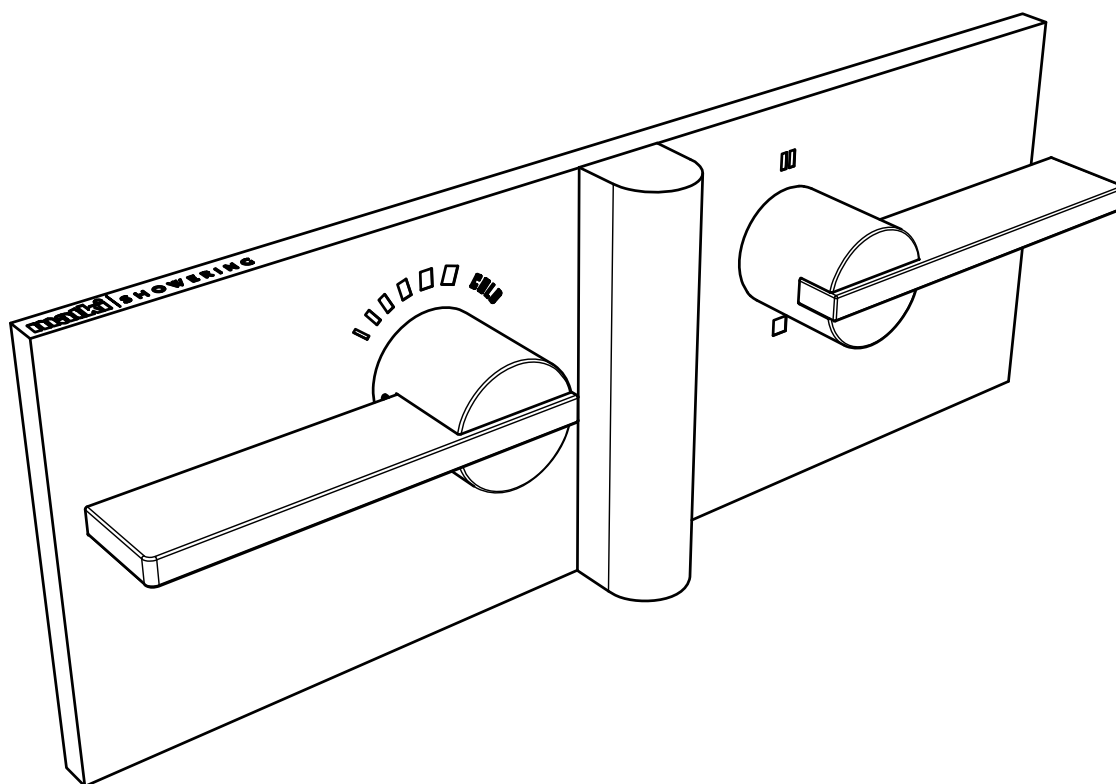

1. IMPORTANT

Please read complete installation instructions before fitting.
Specification. TMV2 valve for use with High and Low Pressure

Condition of use for type 2 valve	High Pressure	Low Pressure
Maximum static pressure - Bar	10 Bar	10 Bar
Flow pressure Hot and Cold - Bar	0.5 to 5.0	0.1 to 1
Hot Supply Temperature °C	55 to 65	55 to 65
Cold Supply Temperature °C	Equal to or less than 25 °C	Equal to or less than 25 °C

Valves operating outside these conditions cannot be guaranteed by the Scheme to operate as Type 2 valves.

For Dynamic flow pressures above 6 bar fit pressure reducers.
Maximum Dynamic flow pressure ratio between hot & cold inlet supplies = 5:1
Optimum performance when inlet pressures are nominally balanced to within 10% of each other during flow.
The shower mixer can accept temporary elevated temperatures to 85°C without damage.
Hot water storage temperatures should be maintained between 60-65°C.

Recommended outlet temperatures

44°C for bath fill see notes below

41°C for showers

41°C for washbasins

38°C for bidets

Mixed water temperatures must never exceed 46°C.

The maximum mixed water temperature can be 2°C above the recommended maximum set outlet temperatures.
Note.

46°C is the maximum mixed water for a bath tap. The maximum temperature takes account of the allowable temperature tolerances inherent in thermostatic mixing valves and temperature losses in metal baths.
It is not a safe bathing temperature for adults or children.

The British Burns Association recommends 37 to 37.5°C as a comfortable bathing temperature for children.
In premises covered by Care Standards Act 2000, the maximum mixed water outlet temperature is 43°C.

The thermostatic mixing valve must be installed in such a position that maintenance of the TMV and its valves and the commissioning and testing of the TMV can be undertaken.

See commissioning notes Stage 8. Setting Temperature

The valve is suitable for all water systems including Gravity fed, Pumped Systems, Combination Boilers, Condensing Boilers, Mains Pressure fed Systems.
The Bath mixer variant is rated only as a high pressure TMV2 thermostatic mixer and we recommend 0.5bar minimum.
However if used in low pressure gravity feed installations (see flow rates) to maximize flow rates use 22mm pipe work reducing to 15mm close to the inlets for the HOT and COLD supplies.

Fit isolation valves as close as is practicable to both the HOT and COLD inlet supplies.

Before disposing of the carton and/or commencing assembly, please check all the parts to ascertain that none are missing and they are all undamaged. No claim for missing/damaged parts will be accepted once the packing carton has been disposed of and/or assembly has commenced.

In case of query contact your Stockist with details of model number, finish and serial number.

DIMENSIONS

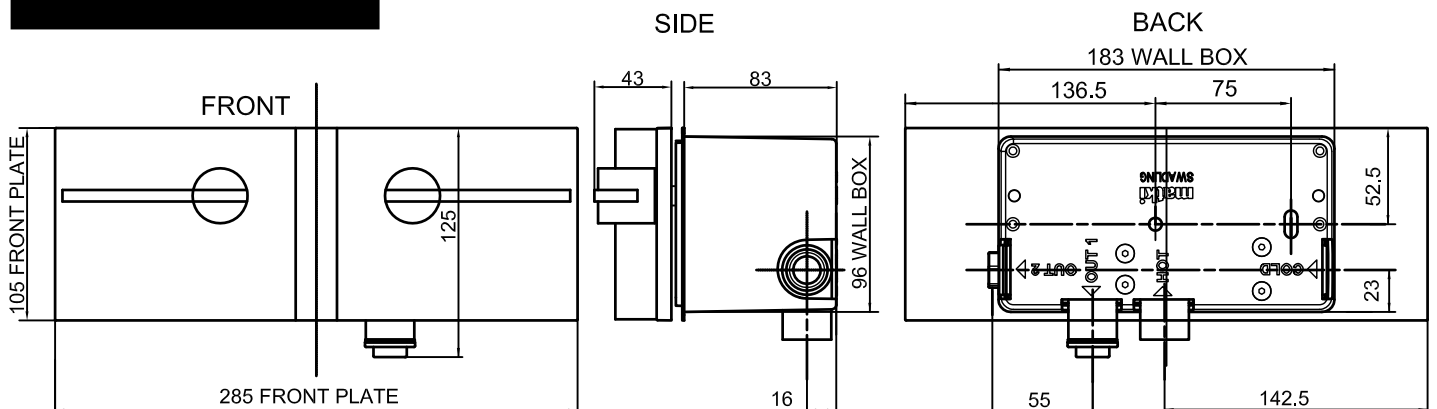

2. CONFIGURATION

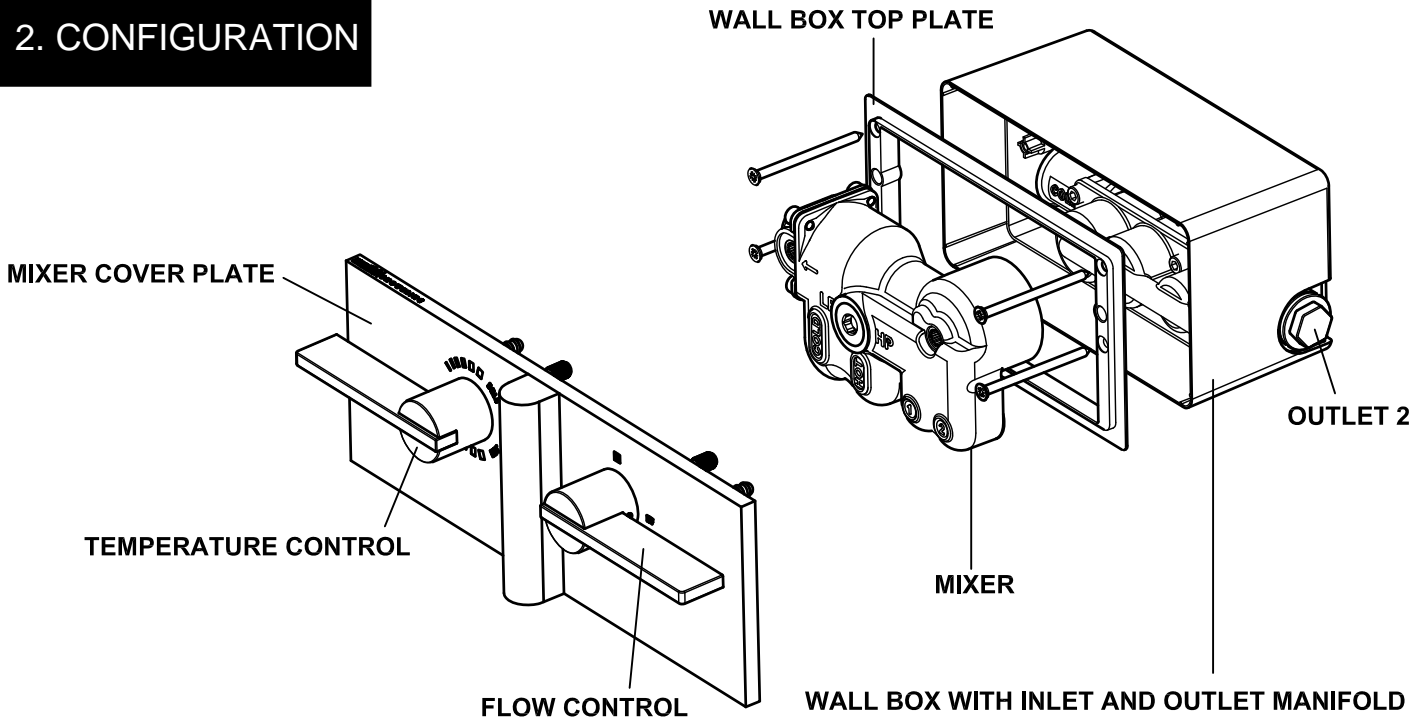

The Elixir Mixer is designed for a 2 stage installation. The first fit wall box manifold can be plumbed and both inlet and outlet connections can be tested and flushed through before fitting the mixer and mixer cover plate. Most problems with any thermostatic mixer valve are caused by debris from new pipe work getting into the thermostat when it is first installed. It is important to flush out all new pipe work before commissioning. The hot and cold inlet non-return valves are fitted with strainers.

The wall box **manifold** has 2 inlets - Hot & Cold, and 2 outlets - Outlet 1 & 2. **Outlet 1** is open, **Outlet 2** is fitted with a sealed blanking plug - although **Outlet 2** can be commissioned if desired (See 5. Operation).

The concealed **mixer** is factory set with an on/off flow control to **Outlet 1** (See 5. Operation).

The Elixir Mixer can only be plumbed horizontally in the configuration shown.

The Hot & Cold inlets and outlets on the manifold are $\frac{1}{2}$ " BSP Female parallel threaded connections.

Important, do not use tapered threaded adaptors when connecting for Hot & Cold inlet and outlet plumbing.

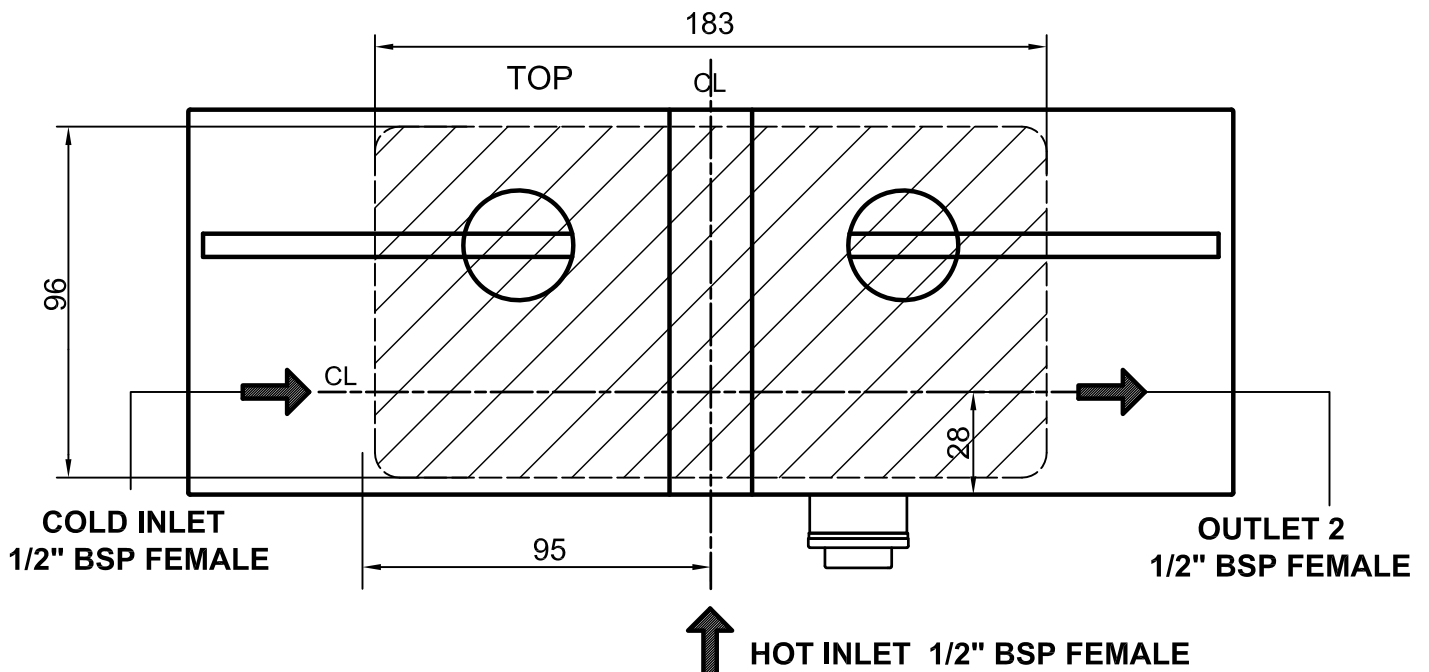

3. WALL BOX / MANIFOLD FIRST FIT

MINIMUM WALL BOX DEPTH

53mm MINIMUM TO PRE TILED SURFACE
 MINIMUM 6mm tile + 30mm of adjustment

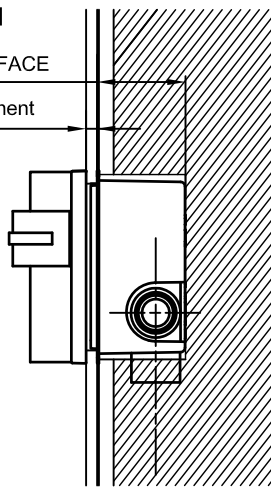

MAXIMUM WALL BOX DEPTH

90mm MAXIMUM TO FINISHED TILE SURFACE
 MAXIMUM 6mm tile at full adjustment

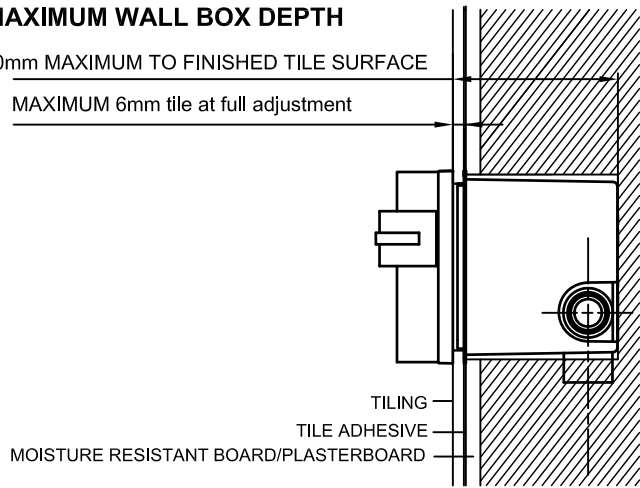

The concealed Shower mixer wall mounting box inlet / outlet manifold can be fitted at a range of depths by cutting the wall box sides down to suit the required depth. The mixer cover plate has a depth adjustment range of **30mm**.

When the mixer control plate is fitted to the wall box the **minimum tile thickness that can be used is 6mm + 1mm of adhesive**. The minimum depth of 53mm for the wall box indicates the minimum trimming depth possible to the pre-tiled surface. The maximum depth 90mm is the maximum depth possible to the finished tiled surface when fitting the wall box without cutting down the wall box sides. If using thicker tiles than 6mm the maximum mounting depth of the wall box will need to be reduced so that the total depth to the finished tile surface is maximum 90mm. See guide below.

Minimum depth 53mm (+) to pre-tiled surface.

Minimum possible calculated with a tile thickness of 6mm +1mm adhesive.
 For thicker tiles the minimum depth = 53 + **tile thickness** - 7mm.

Maximum depth 90mm (-) to finished tiled surface.

Maximum possible calculated with a tile thickness of 6mm +1mm adhesive.
 For thicker tiles the maximum depth = 90 - **tile thickness** + 7mm

Please also allow for plasterboard/plaster or moisture resistant board in mounting depth calculations.

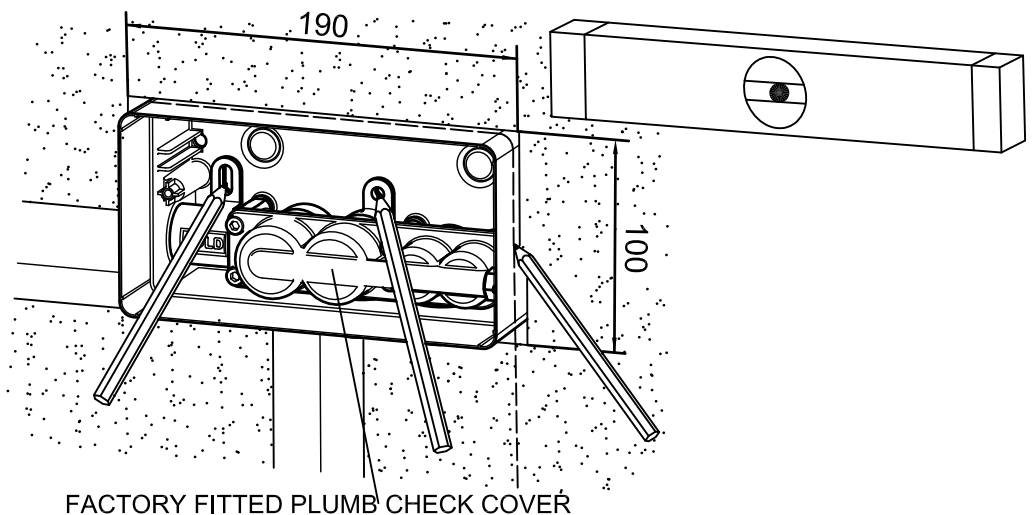

FACTORY FITTED PLUMB CHECK COVER

If mounting the wall box into a wall recess the dimensions required to fit the wall box are 100mm x 190 as shown. Firstly remove the wall box top plate and the No.8 x 63 csk screws and safely store in valve box to use. Before plumbing and fitting the wall box/ manifold connections the wall box sides can be trimmed back to flush or sub flush to the finished pre -tiled surface. If plastering up to the wall box the sides of the box can be trimmed to flush after the plumbing connections have been made and tested. See 4. Wall Box/Manifold Plumbing. Mark the cutting level of the wall box with a felt pen. Then using a junior hacksaw cut the 4 curved corners of the box to the marked level. The box can be cut between the corner levels using a cutting knife or sharp scissors. Alternatively score between the cut corners and bend and snap off the waste sides of the wall box.

The wall box is fixed to the mounting surface using the hole and slotted fixing lugs in the manifold. Level the wall box for horizontal and mark the position of the fixing holes. Drill and fit wall plugs supplied.

4. WALL BOX / MANIFOLD PLUMBING

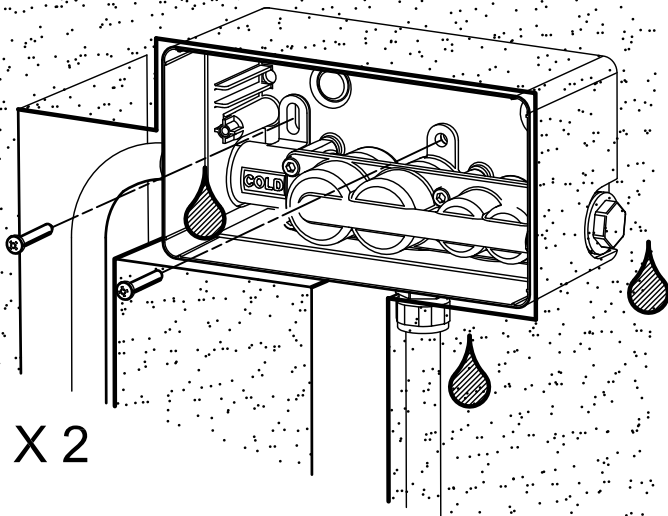

X 2

NO.8 X 32 PAN HEAD

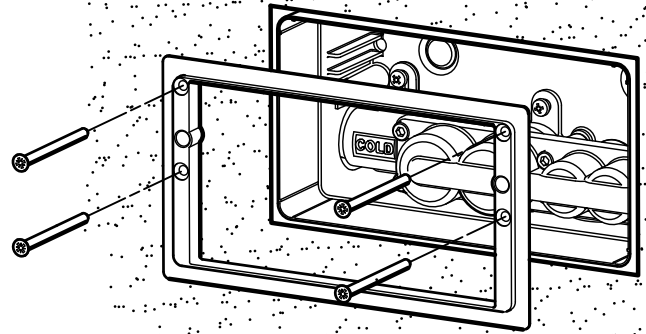
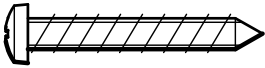

X 4

NO.8 X 63 USE FOR + 60 mm MOUNTING DEPTH

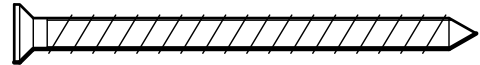

NO.8 X 32 USE FOR - 60 mm MOUNTING DEPTH

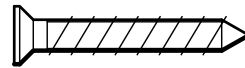

Plumb the Wall box / manifold into position and fix the wall box with the No.8 x 32 Pan head Screws (1471 A SILVER) through the fixing lugs into the manifold casting. Check that the wall box is level adjust as required.

Inlet and outlet threaded joint connections should be made with PTFE tape. Oil based, non setting jointing compounds should not be used. The manifold is factory fitted with a black Plumb Check Cover which houses the non return check valves. The Plumb Check Cover can be used to test the inlet and outlet joints for leakage and for flushing the supply pipes before connecting the Mixer. **Temporary** stop ends could be fitted to the plumbed Outlet(s) to apply back pressure to plumbing connections. **Check that there are no leaks from the wall box manifold casting.**

Important, the Plumb Check Cover will not stop the flow of water through the manifold.

Isolate both hot and cold inlet supplies after flushing pipework and before fitting the shower mixer.

Fit the wall box top plate to the wall box and onto the pre-tiled surface using the fixing screws supplied.

Do not overtighten and distort the plate. **The wall box top plate must be fitted in all installations.**

On installations with a mounting depth **greater** than 60mm use the No.8 x 63mm csk screws. (1302 A SILVER)

On installations with a mounting depth **less** than 60mm use the No.8 x 32mm csk screws. (1478 A SILVER)

Tile over the wallbox top plate flange and up to the inner upstand this will ensure that the Mixer cover plate will overlap tiling. Remove any excess grout from the two Mixer cover plate mounting holes in the wall box top plate. If fitting a panel over the wall box and the wall box top plate the aperture required for the wall box top plate is 91mm x 178mm.

This gives 1mm clearance all around the wall box top plate upstand.

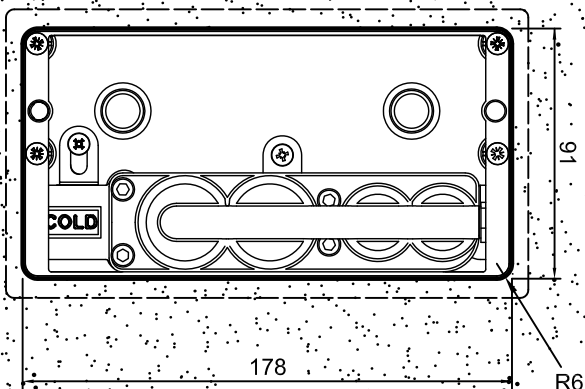

MIXER FRONT PLATE MOUNTING HOLES

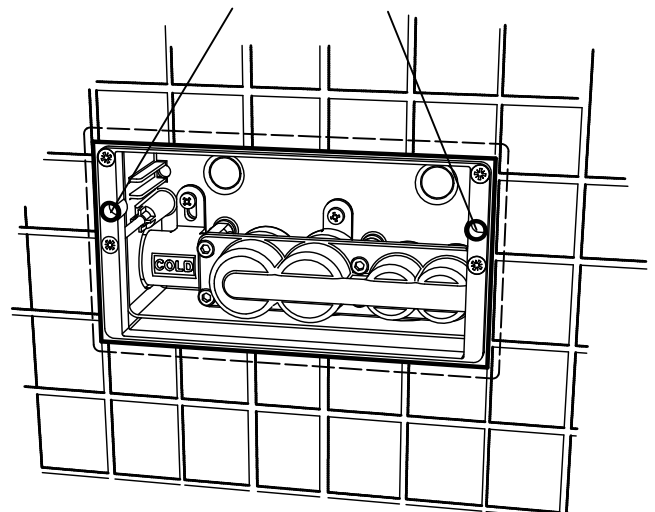

5. OPERATION

TEMPERATURE CONTROL

ROTATE CLOCKWISE FOR COLD

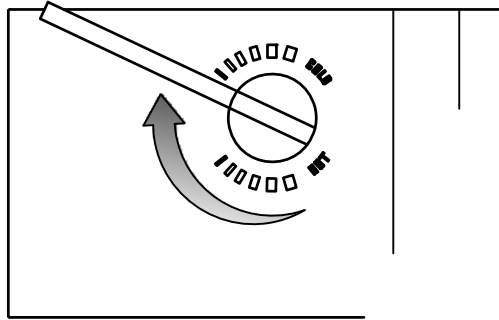

ROTATE ANTICLOCKWISE FOR HOT

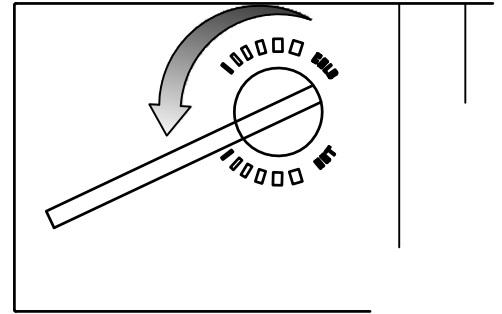

FLOW CONTROL

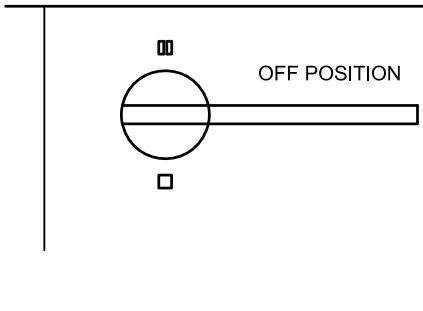

FLOW - OUTLET 1

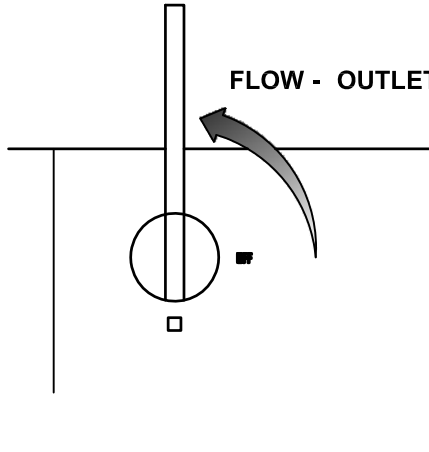

FLOW - OUTLET 2 (IF OPERATIONAL)

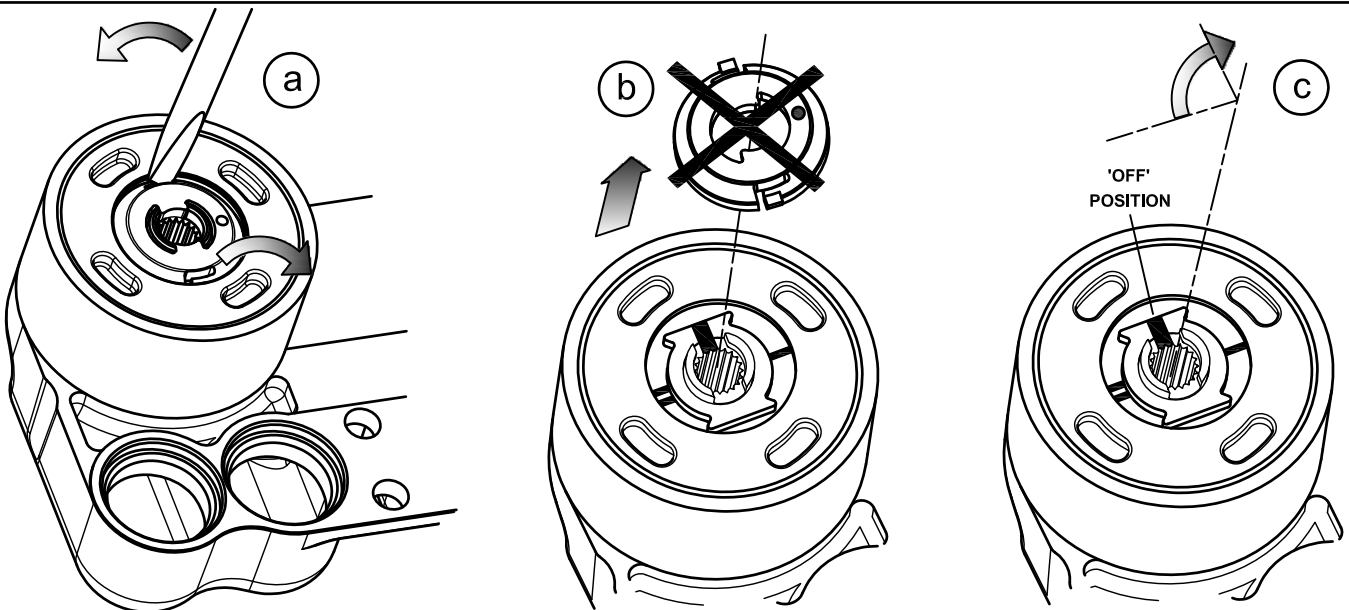
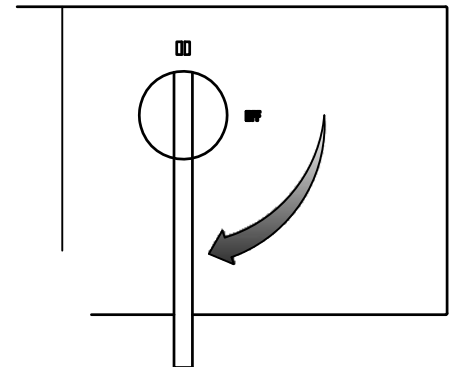

For the Elixir Mixer the **On/Off Cartridge** is factory set to control the flow of water to **Outlet 1** only - for **EX28**, this is used for the **Deluge Shower Head** - See separate fitting instructions for this supplied with the Deluge Shower Head.

The Elixir Mixer can be used as a **Diverter** by changing the following.

1. Before plumbing the **Wall Box/Manifold** remove the sealed blanking plug on **Outlet 2** and plumb as required.
2. Reset the Diverter cartridge to also control the flow of water to **Outlet 2** on the valve (see below).

Resetting the Diverter Cartridge on the Mixer to supply mixed water to Outlet 2

1. Remove the white Diverter stop ring which is marked with **1 dot** using a small flat blade screw driver, lever the ring out by the clip features (this part is now not required) - **(b)**.
2. The **off** position of the Diverter cartridge has been marked at the factory with a line across the top of the green diverter housing and on one edge of the brass central diverter spindle. Rotate the diverter spindle to align the marked lines on both parts **(c)**. The Diverter cartridge is now in the **off** position.

6. FITTING MIXER

NON RETURN VALVE
FOR HOT AND COLD INLETS x 2

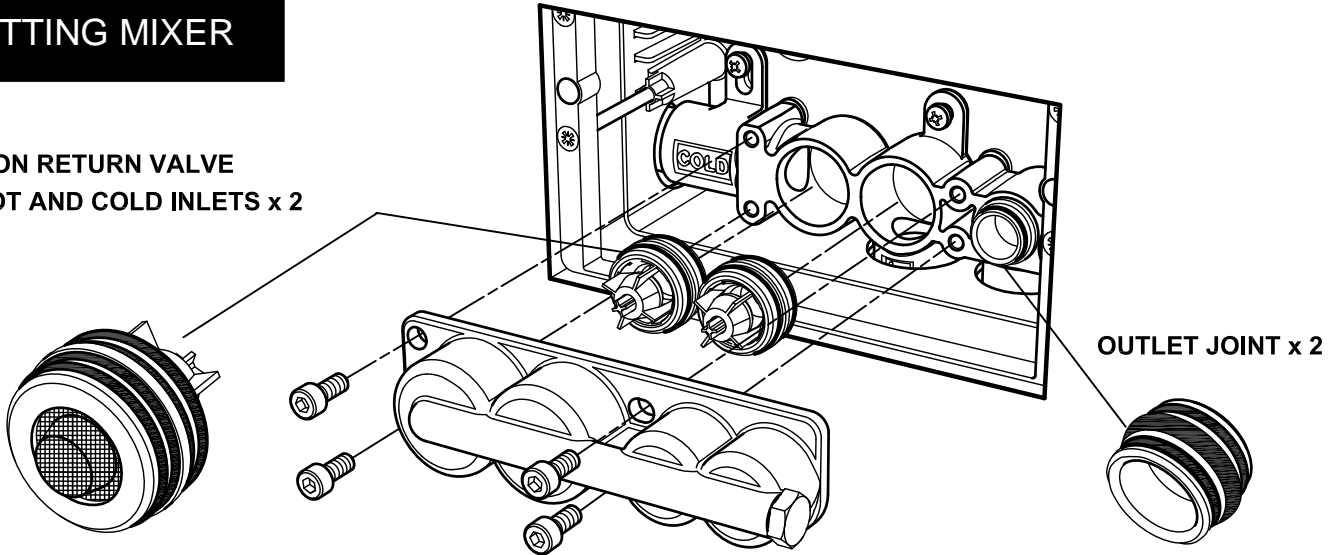

Before fitting the Mixer turn off the hot and cold inlet supplies.

Remove the Plumb check cover plate by unscrewing the 4 x M5 x 12 socket cap screws from the manifold with the Allen key supplied (kit of parts), these screws are also used for fitting the mixer. There will be some water still retained in the system from flushing the pipework which will briefly flow until drained. Dry the area before fitting the mixer.

Remove the hot and cold non return valves from the manifold, check for debris from flushing the pipework on the gauze filter on the bottom of the non return valves. Clean if required and refit the non return valves into the Wall box manifold.

Important, fit the non return valves with the gauze filter facing down into the manifold.

When removing the the Plumb check cover the non return valves and outlet joints may be retained in the Plumb check cover, remove them and fit them into the wall box manifold before fitting the mixer.

We advise that you keep the Plumb check cover it could be used again in a maintenance situation.

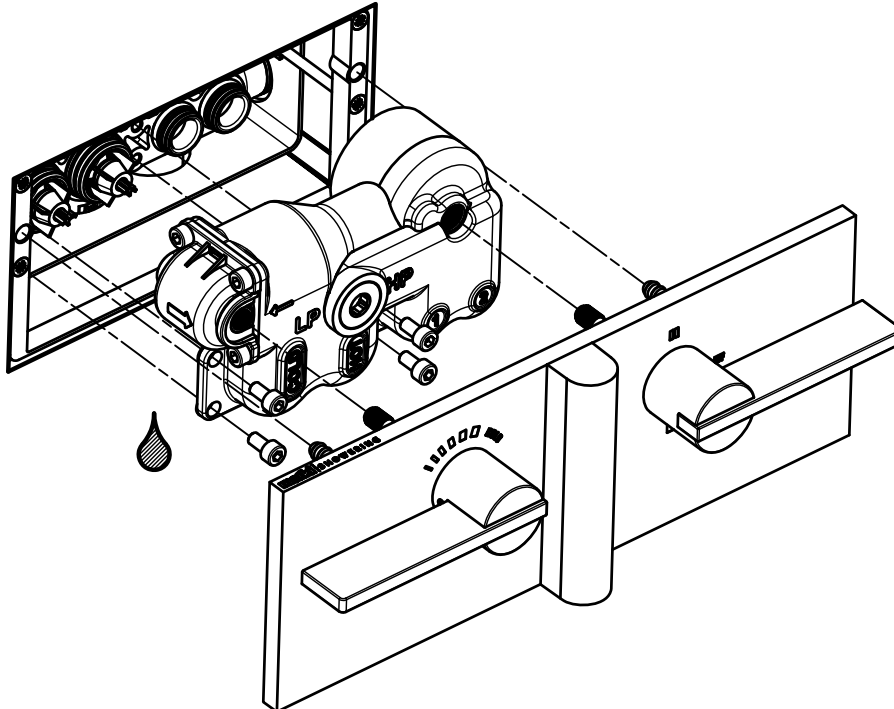

Push fit the Mixer to the manifold onto the inlet and outlet joints. Secure the mixer with the 4 x M5 x12 socket cap screws used to fit the Plumb check cover. Turn on the water supplies. Fit the mixer cover plate **temporarily** to the mixer to test the operation of the mixer. Carefully guide the handle spindles into the splined shaft in the temperature and flow control cartridges and the plate support pins into the wall box top plate.

1. Test the operation of the flow control to **Outlet 1** (and **Outlet 2** if used).
2. Test the operation of the temperature control from hot to cold.
3. Check the inlet and outlet joints between the manifold and mixer for leakage. See '11.Trouble Shooting Guide', if required.

7. FIT MIXER PLATE

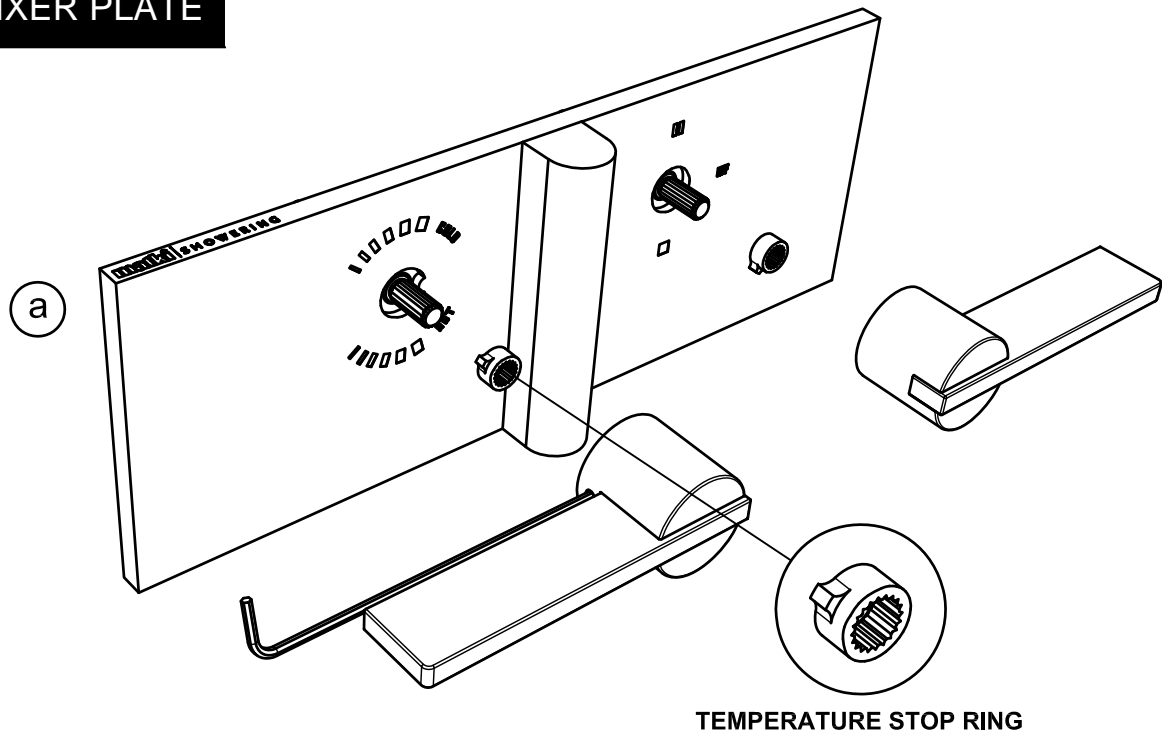

Before the final fit of the mixer cover plate remove the control handles from the plate. Unscrew the handle using the long arm Allen key supplied in the parts kit. The fixing is located under the lever of the handle (a).

Underneath the temperature control handle is the 'temperature stop ring'. This is also used underneath the flow control handle as a 'spacer'. The temperature stop ring is to be used in setting the temperature - Stage 8.

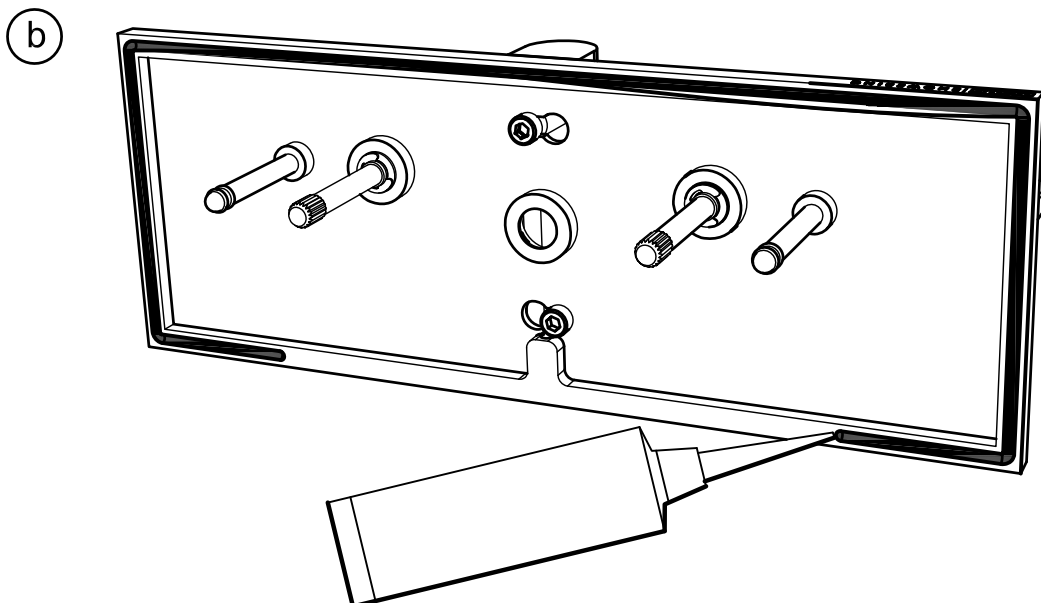

Apply a thin bead of silicon sealant in the groove on the back face of the plate - around the top and vertical edges as well as the bottom edge to the extent of the groove (b).

Do not apply sealant to the middle, bottom edge of the plate - in the unlikely event of an internal leak this will allow for drainage and detection. Fit the mixer front plate to the shower mixer and wall box pressing firmly onto the finished tiled surface. Clean off any excess silicon after the silicon has cured.

Commissioning notes for Thermostatic Mixing Valves.

Please check the following:

- 1.The designation of the thermostatic mixing valve matches the application.
- 2.The supply pressures are within the valve operating range.
- 3.The supply temperatures are within the valve operating range.
- 4.Isolating valves are fitted.

If all these conditions are met set the temperature as per installation instructions

It is a requirement that all TMV2 approved valves shall be verified against the original set temperature results once a year. When commissioning/testing is due the following performance checks should be carried out.

Measure the mixed water temperature at the outlet.

Carry out the cold water supply isolation test by isolating the cold water supply to the TMV, wait for five seconds if water is still flowing check that the temperature is below 46°C.

If there is no significant change to the set outlet temperature(+/- 2°C or less change from the original settings) and the fail-safe shut off is functioning, then the valve is working correctly and no further service work is required.

Notes

If there is a residual flow during the commissioning or the annual verification (cold water supply isolation test), then this is acceptable providing the temperature of the water seeping from the valve is no more than 2°C above the designated maximum mixed water outlet temperature setting of the valve. Temperature readings should be taken at normal flow rate after allowing for the system to stabilise. The sensing part of the thermometer probe must be fully submerged in the water that is to be tested. Any TMV that has been adjusted or serviced must be re-commissioned and re-tested in accordance with the installation instructions.

The installation of the thermostatic mixing valve must comply with the requirements of the Water Supply (Water Fittings) Regulations 1999.

8. SETTING THE TEMPERATURE

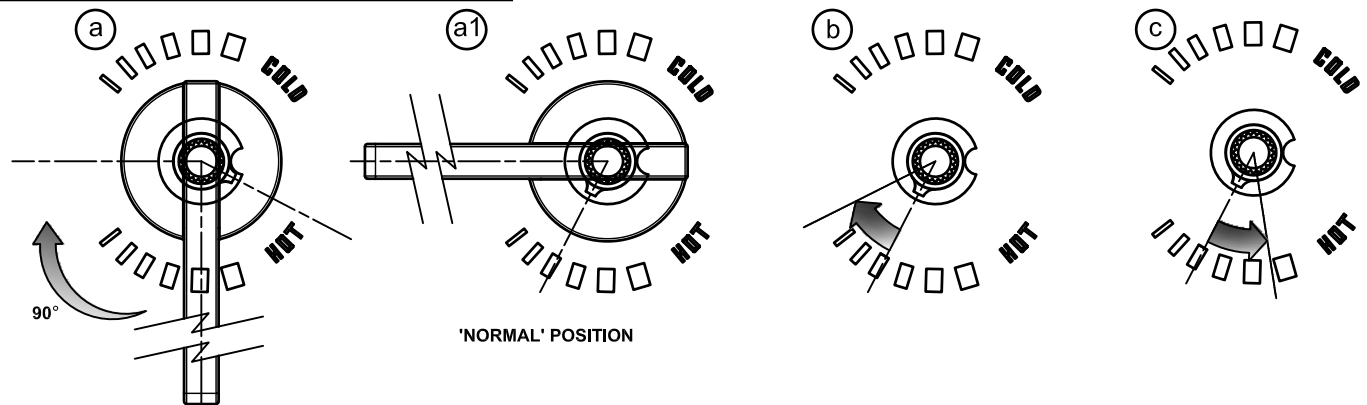

Important : The maximum hot water temperature must be checked and reset if necessary, prior to the mixer being commissioned to avoid scalding. Check that the hot water system is operational and that the hot water supply has reached the optimum temperature.

The temperature control handle has a separate temperature stop ring which is factory fitted under the handle on the spindle. Firstly **remove** the temperature stop ring in order to set the maximum temperature.

The recommended **maximum** hot water temperature from the mixer should not exceed **41°C**.

As a starting point, temporarily fit the handle back on the temperature control spindle, rotate to the full **HOT** position. Refit the handle onto the spindle, with the Handle pointing down, and rotate Handle 90° clockwise - remove Handle.

Locate the temperature stop ring on the spindle in the 'Stop' position and replace handle pointing down (a). Rotate handle 90° clockwise again - this has set the Handle in the 'Normal' position (a1) ready to check the water temperature.

In optimum operating conditions full hot should be approximately 41 °C, however this position may vary due to fluctuating hot and cold supply inlet temperatures. Test the mixer for correct thermostatic operation by checking the current maximum temperature with a thermometer and adjust the position of the temperature stop ring as required.

To increase the maximum hot temperature, fit the stop ring on the spindle spline **closer to cold** .(b)

To decrease the maximum hot temperature, fit the stop ring on the spindle spline **closer to hot** .(c)

When the correct maximum temperature is found, repeat initial stages of step(a), then (a1) to fix the handle in the 'Normal' position. Turn the flow control to off. There is a handle spacer under this handle, fit this handle with the lever aligned to the **off** position. Lock-off both handles using the long arm Allen key provided.

9.MAINTENANCE

TOP FACE

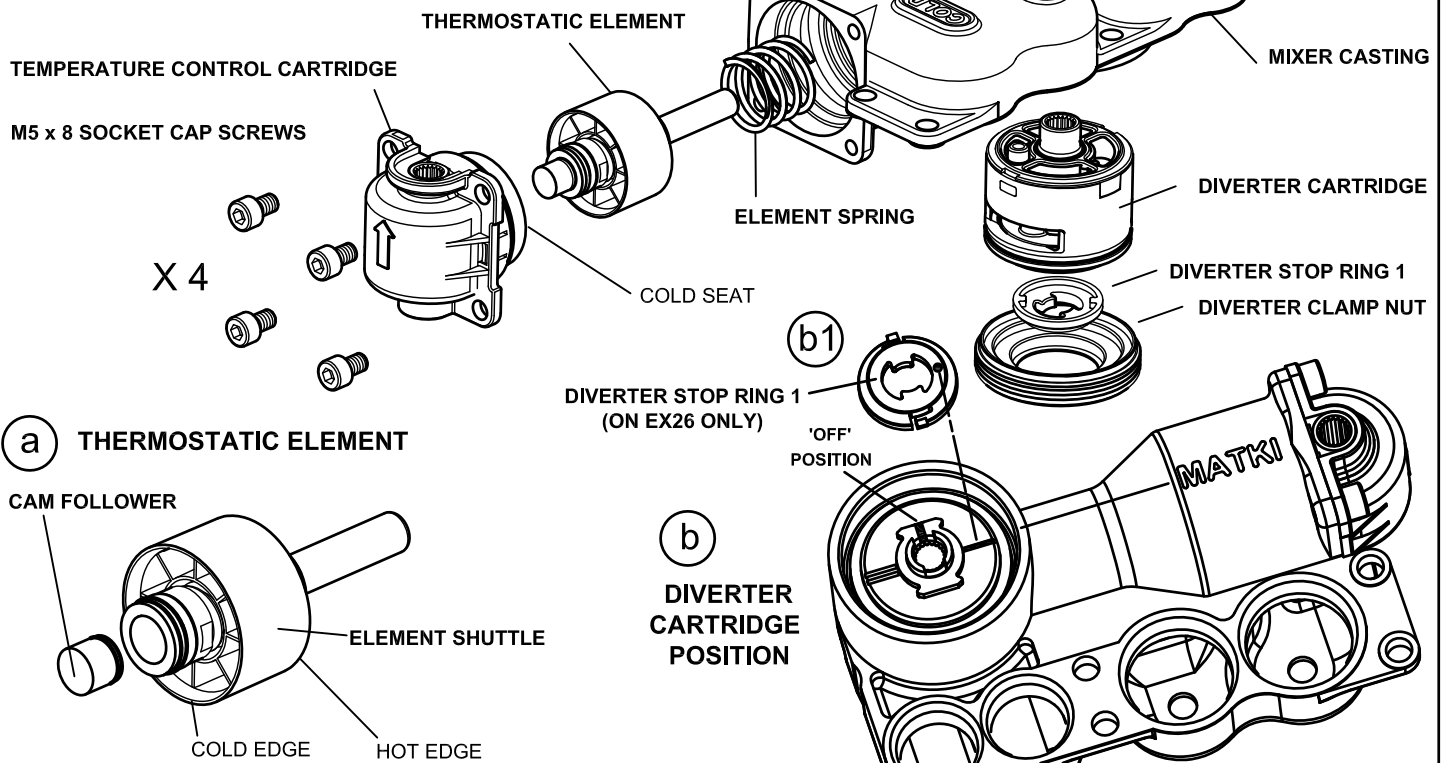

IMPORTANT. Before commencing maintenance on the mixer turn off the hot and cold inlet supplies.

When maintenance is complete ensure that the mixer is checked and fully commissioned before use.

Please see 11.Trouble Shooting guide for fault references.

Remove the Mixer cover plate and unscrew the M5 x 12 socket cap screws to remove the mixer from the manifold.

NON RETURN VALVES. (See 6. Fitting Mixer).

Fault 1. Damaged o-rings on non return valve. Replace with part 1602 AF(supplied in the parts kit SB 2/5245).

Fault 3. Remove and clean any debris and limescale from the gauze filter on the bottom of the part. Clean the non return valves by depressing the plunger and blowing through and refit, or replace with new non return valve part SB 2/5230

MIXER PERFORMANCE (Please see 11.Trouble Shooting guide for fault references).

Fault 6.

Remove the mixer as above and carefully remove the M5 x 8 socket cap screws from the black temperature control cartridge on the mixer body to access the thermostatic element.

The black temperature control cartridge has a rubber seat on the bottom face which is the **cold seat**.

Check for limescale or debris on this seat remove all traces of debris and de-scale as required using a propriety de-scaler.

Check for limescale on the cold edge of the thermostatic element shuttle, de-scale as required.

Fault 7.

The **hot seat** is located inside the mixer casting check for traces of debris on this seat and on the hot edge of the thermostatic element shuttle. **(a)** Flush out the mixer body to remove any debris and de-scale the shuttle as above.

Alternatively if faults 6 & 7 are not resolved replace with a new thermostatic element assembly SB 2/5211.

Important, on refitting the thermostatic element assembly remember to fit the element spring into the mixer first then the thermostatic element ensuring that the cam follower is positioned in the end of the thermostatic element.

Refit the temperature control cartridge with the arrow on the cartridge pointing upwards to the arrow on the mixer casting (eg. top face of casting).

Fault 8.

Unscrew the Diverter Clamp Nut on the bottom of the Mixer to access the Diverter Cartridge.(Insert a flat bladed screwdriver into one notch on the Diverter clamp nut and gently tap in an anticlockwise direction to loosen the nut). Remove the diverter cartridge and replace as required. The diverter cartridge should be in the 'OFF' position when re-fitted.

See 5. Operation, image (c). The Diverter cartridge can only be fitted in one way please ensure that the guide peg on the bottom of the cartridge locates into the single hole in the mixer casting. As a guide the single recessed line on the top of the diverter housing is positioned on the right and aligned with the Matki logo on the mixer casting **(b)**.

If **Outlet 1** is open only (standard factory setting) fit the **Diverter Stop Ring 1** (b1) ensuring Diverter Cartridge is in the 'OFF' position - See 5. Operation, image (c) - and the **single dot** on the Diverter Stop Ring 1 is **aligned** with the **single recessed line** on the diverter housing.

If Mixer has been commissioned so **both Outlets** are open, do not replace Diverter Stop Ring 1.

Replace the Diverter Clamp nut, tighten the nut in a clockwise direction, the nut **can not** be overtightened, the nut will be flush to the mixer casting when tight.

10. PARTS LIST

SB 2/5240

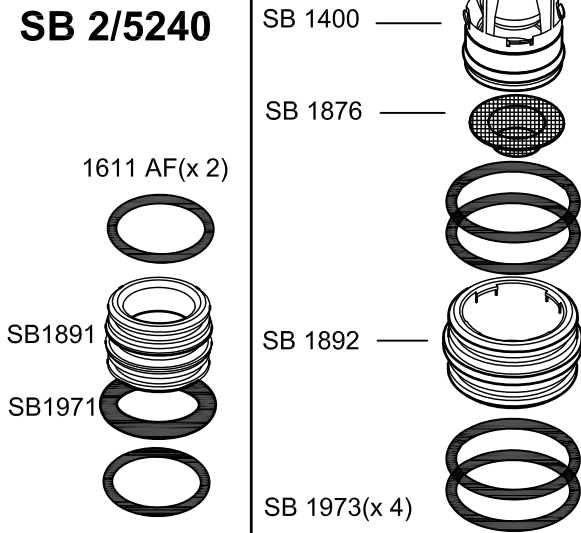

SB 2/5230

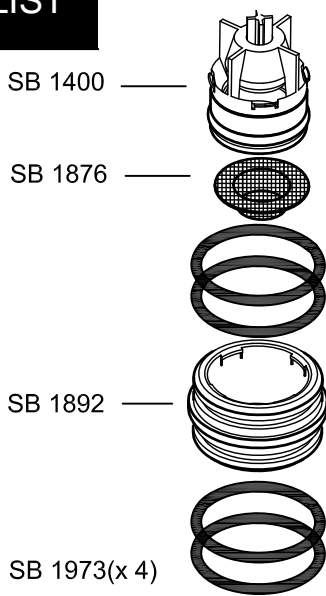

SB 2/5011

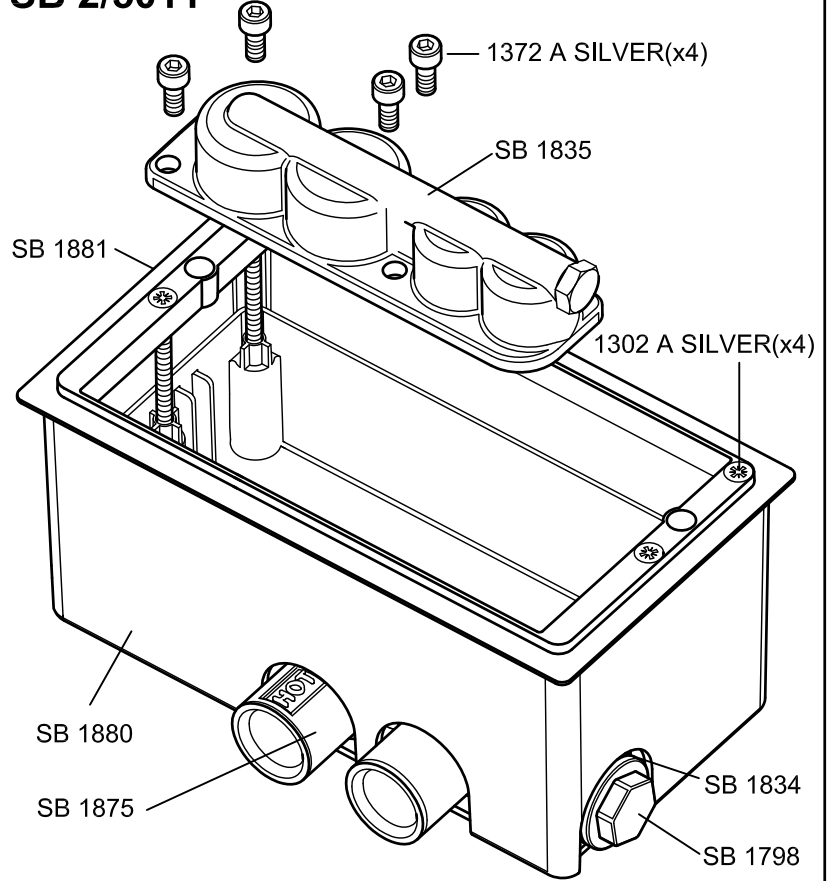

SB 2/5305

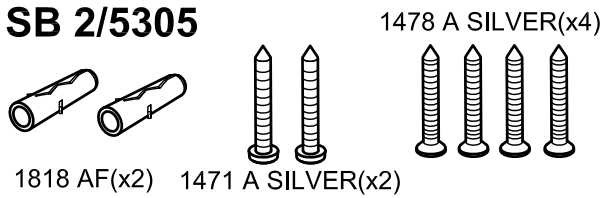

SB 2/5323

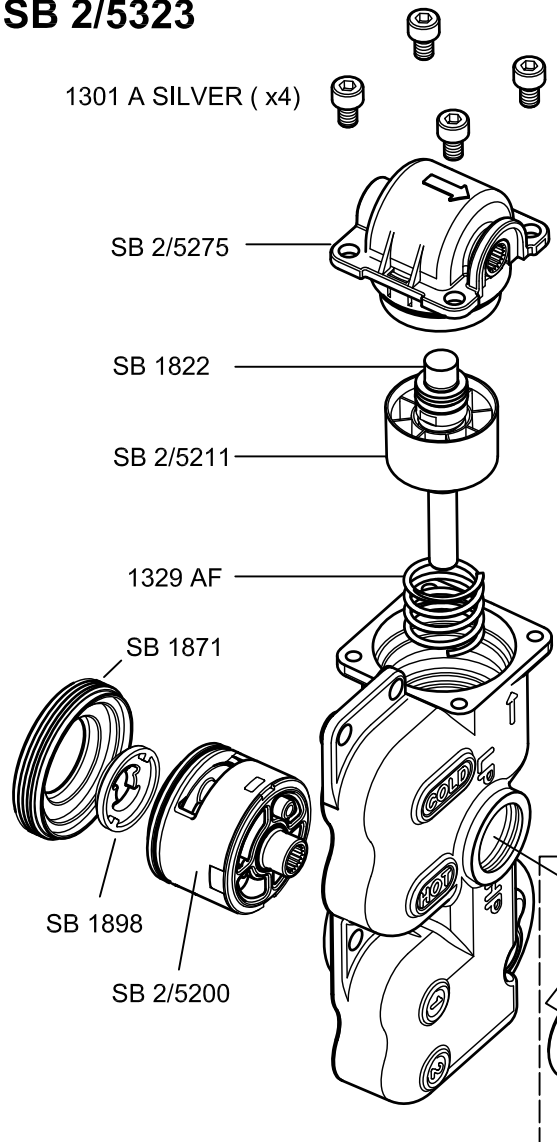

2/6000CP

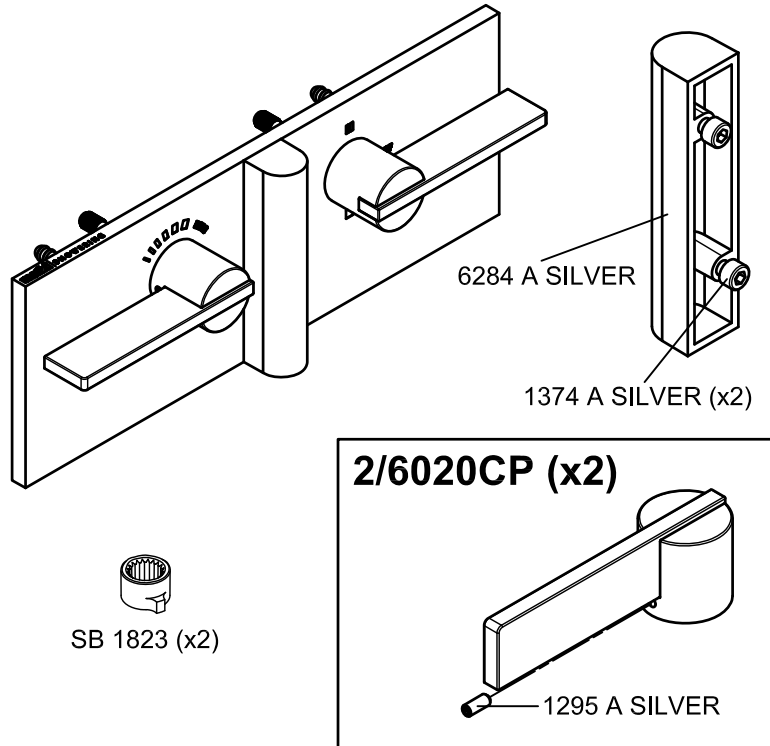

SB 2/5245

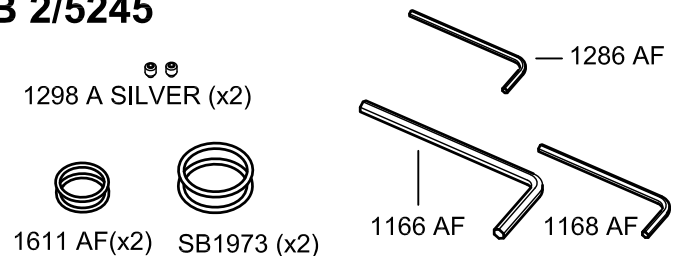

11. TROUBLE SHOOTING GUIDE

1. **Fault, water leaking between Shower valve and manifold.**
Inlet or outlet joints not seated correctly in manifold o-rings not squeezed into inlet or outlet evenly.
Damaged o-rings on inlet or outlet joints in manifold - Replace with spare o-rings supplied in the kit of parts.
2. **Fault, no mixed water to the outlets when turning on the flow control.** See 6. Fitting Mixer.
Non return valves fitted upside down in the wall box manifold.
3. **Fault, cold water cross tracking through mixer into hot water system.**
Non return valves / may need cleaning or replacement. See 9. Maintenance.
4. **Fault, Shower runs Hot when turned to cold, and Cold when turned to hot**
Hot and cold inlet supplies plumbed to wrong inlets on wall box manifold.
5. **Fault, Shower will not run hot when first installed.** See 8. Setting the Temperature.
6. **Fault, Shower only runs cold or lukewarm when first installed.** Thermostat may have debris trapped in COLD side of thermostat. See 9. Maintenance. Fault with thermostatic element. Replace with new thermostatic element.
7. **Fault, Shower only runs HOT.** Thermostat may have debris trapped in HOT side of thermostat. See 9. Maintenance. Fault with thermostatic element. Replace with new thermostatic element.
8. **Fault, Shower lets through, or constantly, drips** Fault in diverter cartridge. Replace diverter cartridge. See 9. Maintenance.
9. **Fault, very low flow or no flow, gravity fed installations.** Very low pressure or blocked filters or pipework.
10. **Fault, no or very little flow, pump fed installations.**
Flow rate may be insufficient to activate booster pump flow switches.
11. **Fault, vibration or hammering.** Dynamic pressure ratio between hot and cold inlet supplies greater than 5:1 maximum. For optimum performance the inlet pressures should be balanced to within 10% of each other.

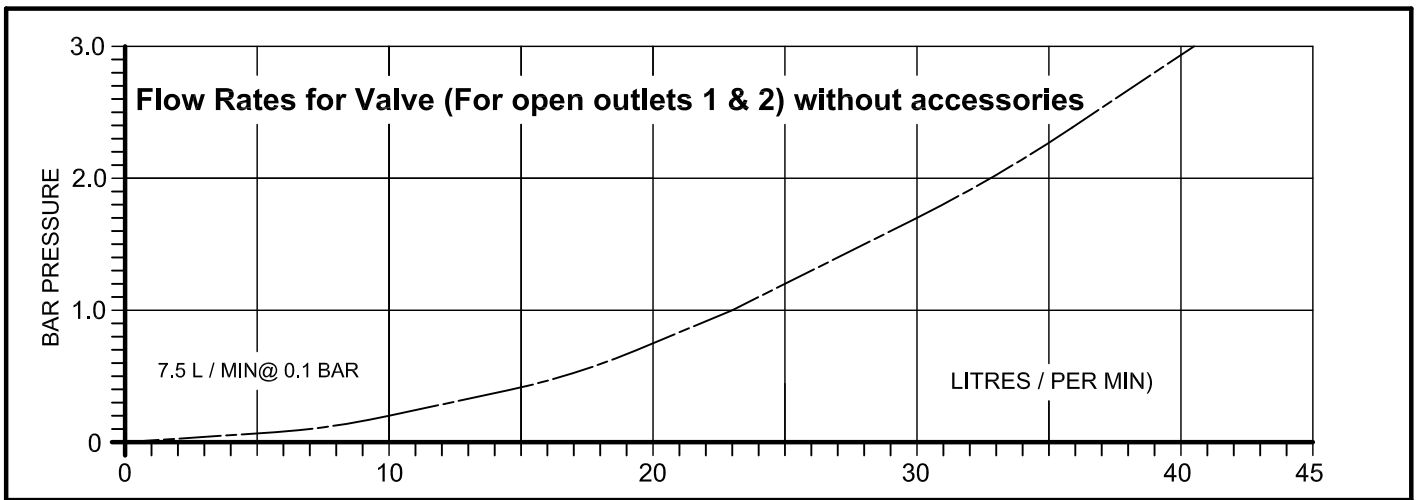

Flow Rate (Litres/min) with Matki accessories		0.1 bar	0.5 bar	1 bar	2 bar	3 bar	Eco		
							1 bar	2bar	3bar
BLADE HAND SHOWER	HIGH FLOW	3	10	11	14	17	N/A		
	ECO	3	6	7.5	9	11	N/A		
BLADE DELUGE			14	17	23	27	11 +/-10%		

Important care of your product

The controls and plate should be maintained by wiping with a soft, damp, clean cloth then polished using a dry duster. **NO** abrasive powder, detergents or polishes should be used. Cleaner containing alcohol, acid or corrosive chemicals should not be used. **Note**, some household bleaches and denture cleaners can damage plated or coloured finishes and if splashed onto a fitting should be immediately washed off with cold water. If these instructions are followed we believe this fitting will give many years of satisfactory use. We have a policy of continuous improvement and reserve the right to change specification without notice.

Guarantee - The Matki Elixir shower mixer is guaranteed for a period of 5 years against defects of materials and workmanship from date of purchase, subject to correct installation, maintenance and use in accordance with this instruction leaflet. Please retain proof of purchase. During the guarantee period parts will be replaced or repaired at our option. No labour costs will be reimbursed unless prior agreement has been obtained from Matki Plc in writing. This guarantee is offered as an extra benefit and does not affect your statutory rights as a consumer in any way whatsoever.

MATKI PLC, CHURCHWARD ROAD, YATE, BRISTOL, BS37 5PL

TELEPHONE:01454 322 888 FAX:01454 315 284 EMAIL:techsupport@matki.co.uk