

This product should only be fitted by a qualified plumber to NVQ (National Vocational Qualification) or SNVQ (Scottish National Vocational Qualification) Level 3. Should the installation be completed by a non-qualified person then the guarantee may be considered invalid.

For a claim made under our warranty written certification of your installers credentials can be required. For further information or to find a qualified installer in your area please visit the Institute of Plumbers website - www.iphe.org.uk

THE QUALIFICATIONS

At present, to be a plumber you need to follow the National Vocational Qualification (NVQ) route (Scottish National Vocational Qualification - SNVQ - in Scotland). These qualifications are made up of theory and practical work in the classroom/purpose built training facility and work based experience with a working plumber. Colleges should help students find a work placement, although many students organise it themselves.

The S/NVQ qualification works in levels. All recently qualified plumbers should hold S/NVQ Level 2 as basic with Level 3 as the preferred level. Level 2 will give you the foundation you need for a career in plumbing and teach you domestic plumbing to a satisfactory level. Level 3 is more comprehensive and deals with domestic, commercial and industrial plumbing along with aspects such as gas - if you want to one day set up your own business, this is the level to reach. The Institute of Plumbing and Heating Engineering, and the industry as a whole recommends that all plumbers reach a minimum of Level 3.

Reaching Level 3 has other advantages. The Institute runs a Master Plumber Certificate, which only those attaining Level 3 or equivalent can reach as long as they have the relevant experience as well. Those with S/NVQ Level 3 can (once in membership with the Institute for five years as a Member MIPHE) gain Engineering Technician EngTech status with the Engineering Council (UK).

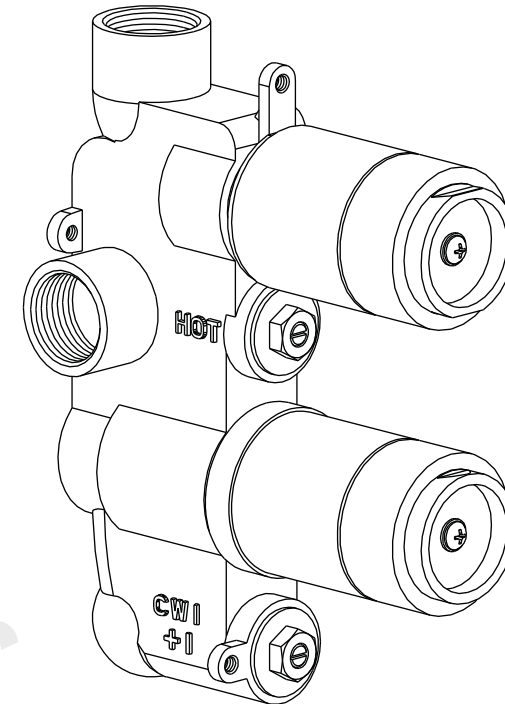

For any further information please contact Crosswater on: **0845 873 8840**

Or visit our web-site at www.crosswater.co.uk

The manufacturer reserves the right to make technical modifications without prior notice.

INSTALLATION INSTRUCTIONS

INTRODUCTION

This thermostatic valve is suitable for use with all water systems up to a maximum operating pressure of 5.0 bar and static pressure of 10 bar. (beyond which pressure reducing valves must be fitted).

The outlet is controlled by a flow control cartridge, commonly used for a main shower head.

PARTS IDENTIFICATION

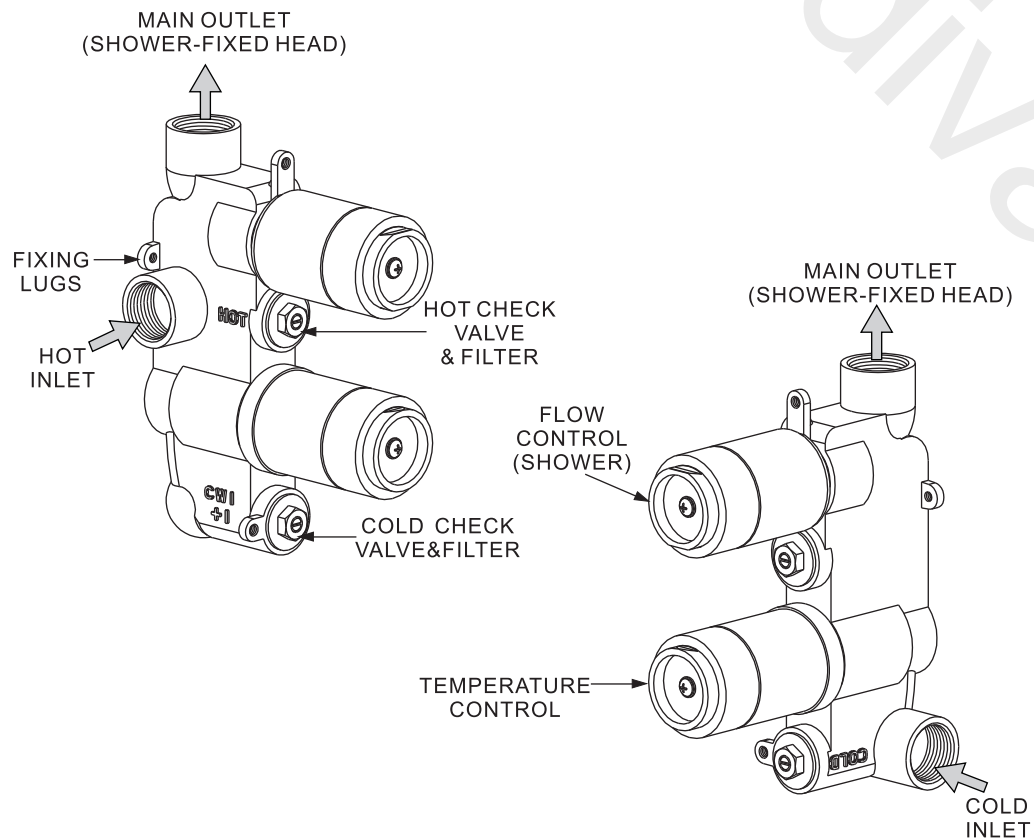

NOTE: FOR ILLUSTRATIVE PURPOSES HANDLES ARE NOT SHOWN

DIMENSIONS

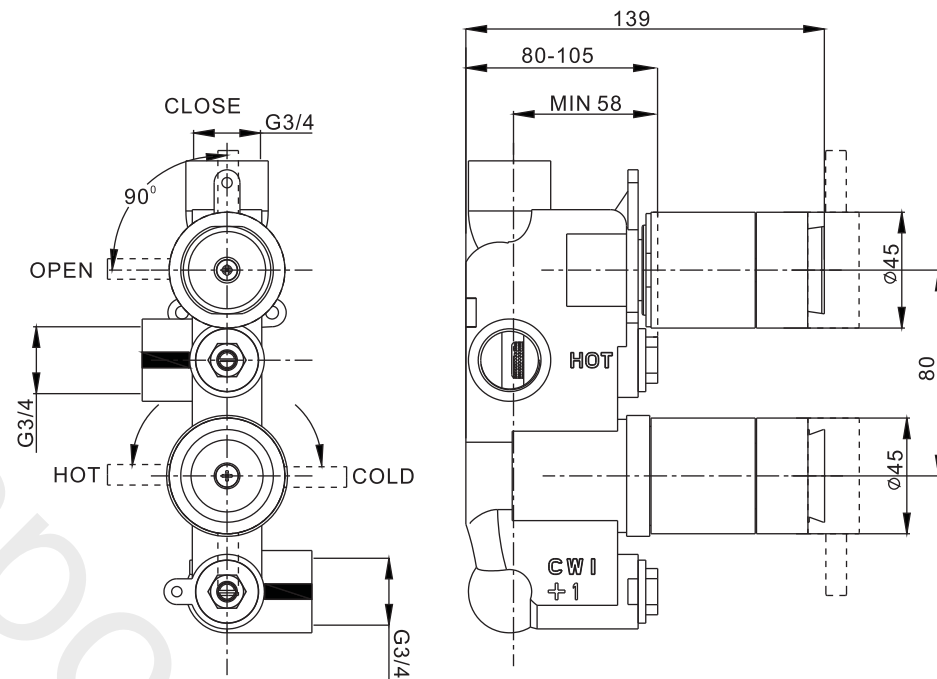

TMV APPROVED INSTALLATIONS

Where valves are required to be installed in accordance with TMV2 or TMV3 requirements please install them strictly in accordance with the instructions on pages 7-13 of this manual.

NOTE: ALL DIMENSIONS IN MILLIMETRES

INSTALLATION

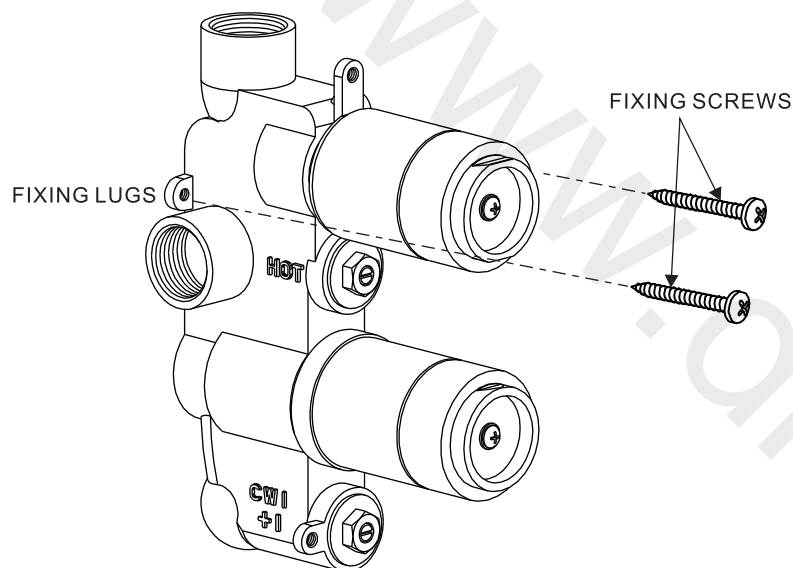

NB. Cover plate shown for illustration purposes only. It is supplied separately various styles available.

For all Water square (WS prefix) please additional installation instruction before completing any of the tiling.

FIG. 1 FITTING PLASTIC DUST COVER

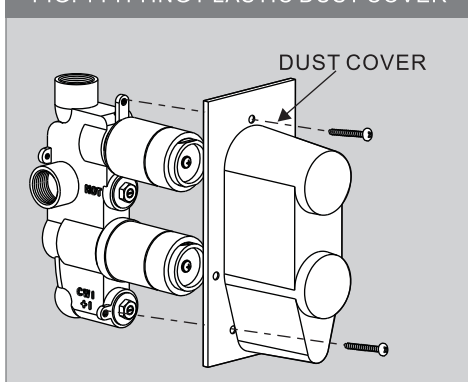
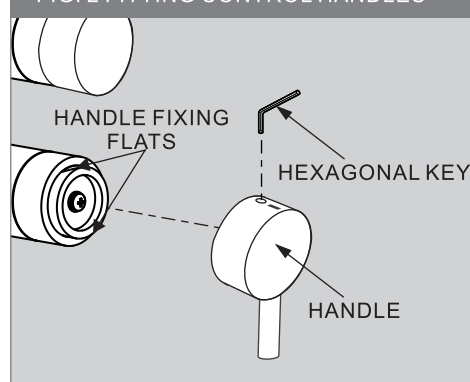

FIG. 2 FITTING CONTROL HANDLES



INSTALLATION

NOTES:

Please read these instructions carefully and keep in a safe place for future reference. The installation must comply with all Local/National Water Supply Authority Regulations/Bye laws and Building and Plumbing Regulations (UK: BS6700). This valve is a mixing device and therefore requires the water supplies to be reasonably balanced, otherwise we recommend a pressure reducing valve to be fitted.

The valve is fitted with integral WRC approved single check valves cartridges which command the water supply, therefore the thermostatic valve is protected against cross-flow due to unbalanced line pressures as required by the Water Supply (Water Fittings) Regulations 1999.

Fitting isolating valves to the inlet feeds is recommended for ease of maintenance.

INSTALLATION

Remember to turn off the mains water supply before connecting to any existing pipe work.

Warning! Please check for any hidden pipes and cables before drilling holes in the wall.

Position the valve onto the wall and mark the position of the fixing lugs (x2). Make sure the valve is set back from the front face of the wall by the appropriate depth to allow for plasterboard, filling and tiling etc. (min. 78mm to max. 105mm see dimension page).

Mount casting to the wall using suitable fixings.

Always leave access to the four front cartridges for servicing.

Once the valve has been secured to the wall, the black Plastic Dust Cover can be temporarily attached to the valve with the screws supplied. This will protect the valve while the rest of the work is completed (**see fig 1**).



Do not use tapered threaded adaptors or excessive thickness of sealing tape as this may damage the valve body and result in a concealed leak within the wall cavity.

Blank off and seal the open outlet if it is not required.

Remove the Plastic Dust Cover.



Turn on supplies and test all connections for water tightness.

Remove Hot and Cold check valves, and flush out the installation, clean the filters and refit.

Apply a narrow bead of clear silicone sealant around the back edge of the cover plate and carefully press into position.

Fit the control knobs by lining up the flat surface of the valve cover with the grub screw on the handle, tighten the screw with the supplied hexagonal key (**see fig 2**).

TEMPERATURE SETTING

To set the temperature, remove the handle and unscrew the centre screw of the thermostatic control cover. Rotate the exposed thermostatic spindle (clockwise for cold, and anti-clockwise for hot) until the maximum desired showering temperature is set (42°C-suggested maximum "pre-set" temperature). Then line up the screw head on the back of the thermostatic control cover with the stop on the cartridge. Push the control cover onto the splines and tighten the centre screw, refit the handle. The thermostat is now set to its new temperature and can only be increased or decreased by repeating this process.

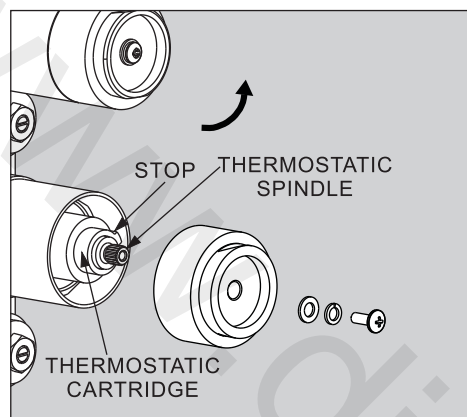

MAINTENANCE

Note: To avoid damage, please remove all chrome parts before any maintenance takes place.

THERMOSTATIC CARTRIDGES

The 1" concealed thermostatic valve should give trouble free service, but in the event of failure, servicing is straight forward.

To remove the thermostatic cartridge. Undo the cartridge clamp nut (take note of the orientation of the cartridge) and pull the cartridge out using the temperature control knob to aid removal. Wash the cartridge with clean running water and make sure that any trapped debris has been removed. Dry and lightly grease the seals (only use silicone grease) and replace the cartridge making sure that as before the recess on the body of the valve is aligned with the slot in the raised central section of the plastic cartridge. This is to make sure the lug on the shroud is in the required 2 o'clock position as shown.

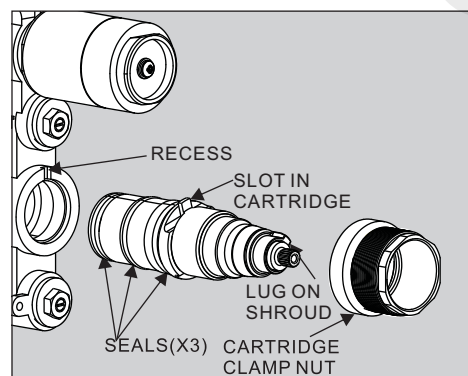

FLOW CONTROL CARTRIDGE

The Flow Control Cartridge uses ceramic discs which normally last indefinitely unless debris manages to get between them. Wash the cartridge with clean running water, dry and lightly grease the seal.

MAINTENANCE

FILTERS/CHECK VALVES

The check valves stop cross flow between the hot and cold supplies.

To clean the Check Valves.

Undo and remove the Check valve. Using a pair of pliers remove the Non return valve and filter. Wash the filter with clean running water, dry and lightly grease the seals.

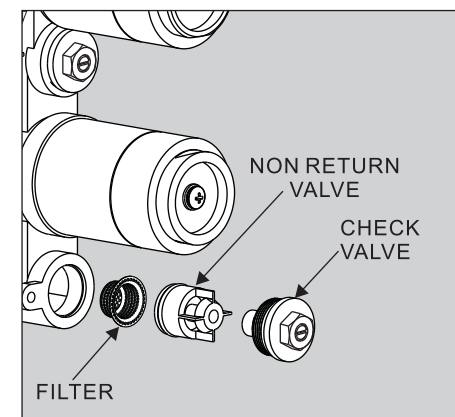

CARE OF YOUR SHOWER VALVE

We recommend cleaning the valve with a soft damp cloth. We strongly advise against the use of ALL cleaning products.

TROUBLE SHOOTING

SYMPTOM	SOLUTION
After installation the shower runs HOT or COLD and will not mix.	Hot and cold supplies are plumbed the wrong way round. The hot and cold supplies need to be redone to the correct inlets as marked and described in the installation instruction.
Shower will not run hot enough when first installed.	Maximum temperature needs adjusting, see 'temperature setting'.
Cold water tracking through the valve into the hot water system.	Check and clean the check valve cartridges and filters located under the check valves.
Very low flow or no flow (gravity).	Check hot and cold feeds (the valve will shut down if either the hot or cold supply fails).

Thermostatic Mixing Valves Maintenance & Installation Instructions for Compliance with the TMV3 Scheme

1. Operating Conditions of Use

Before installation the On Site Service conditions of use must be checked by the installer. The table below contains details of the normal conditions for operation of these valves. If your water supply cannot meet these conditions then the valve Crosswater supply cannot be guaranteed to operate as a Type 3 valve.

If a water supply is fed by gravity then the supply pressure is likely to be insufficient for the correct operation of this valve.

Valves cannot operate effectively where a hot or cold pressure system crosses the boundaries of the two operating pressure ranges (0.2 to 1.0 bar and 1 to 5 bar.). In the case where operating conditions such as these exist; either the hot or cold pressure will require to be boosted so as to be within the pressure range shown below. Operating pressures above 5.0 Bar will require the installation of a pressure reducing valve.

2. Conditions of Use for Type 3 Valves.

	High Pressure (H.P.)
Maximum Static Pressure Bar	10
Flow Pressure, Hot & Cold - Bar	1 to 5
Hot Supply Temperature - °C	52 - 65°C
Cold Supply Temperature - °C	-5 - 20°C
Minimum temperature differential :	11

NOTE: Valves operating outside these conditions of operation cannot be guaranteed by the Scheme to operate as Type 3 valves

The valves designation of use is High Pressure Shower (HP-S).

3. Outlet Temperature.

The BuildCert TMV Scheme states that the following set maximum mixed water outlet temperatures should be set.

Application	Mixed water temperature (at point of discharge) °C
Shower	41°C

The Thermostatic Shower Valve must be installed and commissioned correctly to ensure that water is supplied at a safe temperature to the users.

4. Valve Installation.

The Valve must be installed so as to be:

Accessible for commissioning and maintenance

The supplies must be fitted with Isolation Valves on both hot and cold water systems as close as possible to the valve, these valves must be accessible so as to be available for commissioning and future on-site tests.

This valve is fitted with integral strainers mounted under the circular covers on the body of the valve and "listed" single check valve cartridges, these are mounted within the Inlet Connections of the body. The thermostatic valve thus is protected against cross-flow due to unbalanced line pressures as required by the Water Supply (Water Fittings) Regulations 1999.

5. Setting up the valve for operation.

This Thermostatic Mixing Valve is factory set to the required temperature. Check the valve after installation to ensure it operates at the correct outlet temperature.

Fit the temperature control knob so as to bring the temperature limiting stop situated in the temperature control knob against the stop mounted on the plastic valve cartridge so as to limit the valve to desired maximum temperature. When correctly fitted the valve should only be capable of being turned from the stop in the direction of the cold arrow.

Screw the temperature control knob firmly in position, using the lock-screw provided; and then check once more the maximum desired temperature cannot be exceeded. The valve is now ready for use.

It is requirement for showers operating to TMV3 that the set temperature should be set at 41°C maximum.

6. Method for Commissioning Thermostatic Mixing Valves.

Purpose.

Since the installed supply conditions are likely to be different from those applied in the laboratory tests it is appropriate, at commissioning, to carry out some simple checks and tests on each mixing valve to provide a performance reference point for future in-service tests.

Procedure.

Check that:

- a) the designation of the thermostatic mixing valve matches the intended application
- b) the supply pressures are within the range of operating pressures for the designation of the valve

c) the supply temperatures are within the range permitted for the valve and the guidance information on the prevention of legionella etc.

Adjust the temperature of the mixed water in accordance with the Manufacturer's instructions in above for the application and then carry out the following sequence:

- a) record the temperature of the hot and cold water supplies
- b) record the temperature of the mixed water at the largest draw-off flow rate
- c) record the temperature of the mixed water at a smaller draw-off flow rate, which shall be measured
- d) isolate the cold water supply to the mixing valve and monitor the mixed water temperature
- e) record the maximum temperature achieved as a result of (d) and the final stabilised temperature

NOTE: The final stabilised mixed water temperature should not exceed the values in Table 17

f) record the equipment, thermometer etc. used for the measurements

Table 17: Guide to maximum stabilised temperatures recorded during site tests

Application	Mixed water temperature °C
Shower	43°C

7. In Service Testing.

Purpose

The purpose of in-service tests is to regularly monitor and record the performance of the thermostatic mixing valve. Deterioration in performance can indicate the need for service work on the valve and/or the water supplies.

Procedure

Using the same measuring equipment or equipment to the same specification as used in the commissioning of the valve, adjust the temperature of the mixed water in accordance with the manufacturer's instructions and the requirement of the application. Carry out the following sequence:

- a) record the temperature of the hot and cold water supplies
- b) record the temperature of the mixed water at the largest draw-off flow rate
- c) record the temperature of the mixed water at a smaller draw-off flow rate, which shall be measured

If the mixed water temperature has changed significantly from the previous test results (e.g. > 1 K) record the change and before re-adjusting the mixed water temperature check:

- a) that any in-line or integral strainers are clean
- b) any in-line or integral check valves or other anti-back siphonage devices are in good working order
- c) any isolating valves are fully open

With an acceptable mixed water temperature, complete the following procedure:

- a) record the temperature of the hot and cold water supplies
- b) record the temperature of the mixed water at the largest draw-off flow rate
- c) record the temperature of the mixed water at a smaller draw-off flow rate, which shall be measured

d) isolate the cold water supply to the mixing valve and monitor the mixed water temperature

e) record the maximum temperature achieved as a result of (d) and the final stabilised temperature

f) record the equipment, thermometer etc. used for the measurements

If at step (e) the final mixed water temperature is greater than the value of 43°C and / or the maximum temperature exceeds the corresponding value from the previous results by more than about 2 K, the need for service work is indicated

NOTE: In-service tests should be carried out with a frequency, which identifies a need for service work before an unsafe water temperature can result. In the absence of any other instruction or guidance, the procedure described in Annex F of D 08 may be used.

8. Annex F of D 08 (informative).

Frequency of in-service tests

General

In the absence of any other instruction or guidance on the means of determining the appropriate frequency of in-service testing, the following procedure may be used:

- a) 6 to 8 weeks after commissioning carry out the tests detailed in "In-Service Tests"
- b) 12 to 15 weeks after commissioning carry out the tests detailed in "In-Service Tests"

Depending on the results of the above tests, several possibilities exist:

- a) If no significant changes (e.g. ≤ 1 K) in mixed water temperatures are recorded between commissioning and 6 to 8 week testing, or between commissioning and 12-15 week testing the next in-service test can be deferred to 24 to 28 weeks after commissioning.
- b) If small changes (e.g. 1 to 2 K) in mixed water temperatures are recorded in only one of these periods, necessitating adjustment of the mixed water temperature, then the next in-service test can be deferred to 24 to 28 weeks after commissioning.
- c) If small changes (e.g. 1 to 2 K) in mixed water temperatures are recorded in both of these periods, necessitating adjustment of the mixed water temperature, then the next in-service test should be carried out at 18 to 21 weeks after commissioning.
- d) If significant changes (e.g. > 2 K) in mixed water temperatures are recorded in either of these periods, necessitating service work, then the next in-service test should be carried out at 18 to 21 weeks after commissioning.

The general principle to be observed after the first 2 or 3 in-service tests is that the intervals of future tests should be set to those which previous tests have shown can be achieved with no more than a small change in mixed water temperature

9. Water Supply (Water Fittings) Regulations 1999.

This valve must comply with the requirements of the above regulations and installation should be carried out in strict compliance with them.

10. Aftercare.

Crosswater Thermostatic Shower Valves should be treated with care.

Do not use abrasive cleaners as this may cause damage. An occasional wipe with a soft damp cloth followed by a thorough rinsing is all that is required.

Thermostatic Mixing Valves Maintenance & Installation Instructions for Compliance of the TMV2 Scheme

Operating Conditions of Use.

Before installation the on site service or conditions of use must be checked. The table below contains details of the Requirements for operation. If your water supply cannot meet these conditions then the valve cannot be guaranteed to operate as a Type 2 valve.

If a water supply is fed by gravity then the supply pressure should be verified to ensure the conditions of use are appropriate for the valve.

Valves cannot operate effectively where a hot or cold pressure system crosses the boundaries of the two ranges. In the case where operating conditions such as these exist; either the hot or cold pressure will require to be reduced or boosted so as to be within a selected range. Operating pressures above 5.0 Bar will require the installation of a pressure reducing valve.

Conditions of use for Type 2 valves

	High Pressure	Low Pressure
Maximum Static Pressure Bar	10	
Flow Pressure, Hot & Cold - Bar	0.5 to 5	0.1 to 1
Hot Supply Temperature - °C	55 to 65	
Cold Supply Temperature - °C	Equal to or Less than 25°	

NOTE: Valves operating outside these conditions cannot be guaranteed by the Scheme to operate as Type 2 valves.

Designation of use HP-S & LP-S

Recommended outlet temperatures

The BuildCert TMV scheme recommends the following set maximum mixed water outlet temperatures for use in all premises: 41°C for showers;

The thermostatic shower mixing valve must be installed and commissioned correctly to ensure that water is supplied at a safe temperature to suit the users. 43°C is the maximum temperature, and is not a safe bathing temperature for adults or children. The British Burns Association recommends 37 to 37.5°C as a comfortable washing temperature for children. In premises covered by the Care Standard Act 2000, the maximum mixed water outlet temperature is 43°C.

Valve Installation

Install in accordance with the accompanying installation guide. The valve must be installed so as to be:-

- Readily accessible for commissioning and maintenance
- The supplies must be fitted with isolation valves on both the hot and cold water systems as close as possible to the valve.

The valve is fitted with integral strainers and "listed" single check valve cartridges, therefore the thermostatic valve is protected against cross-flow due to unbalanced line pressures as required by the Water Supply (Water Fittings) Regulations 1999.

Commissioning and Testing

The first step in commissioning a thermostatic mixing valve is to check the following:

1. The designation of the thermostatic mixing valve matches the application.
2. The supply pressures are within the valves operating range.
3. The supply temperatures are within the valves operating range.
4. Isolating valves (and strainers preferred) are provided.

If all these conditions are met, proceed to set the mixed water outlet temperature.

The Thermostatic Mixing Valve is factory set to the required temperature. Check the valve after installation to ensure it operates at the correct outlet temperature.

Fit the temperature control knob so as to bring the temperature limiting stop situated in the temperature control knob against the stop mounted on the plastic valve cartridge so as to limit the valve to the desired maximum temperature. When correctly fitted the valve should only be capable of being turned from the stop in the direction of the cold arrow.

Screw the temperature control knob firmly in position, using the lock-screw provided; and then check once more the maximum desired temperature can not be exceeded. The valve is now ready for use.

It is recommended for showers that the set temperature should be set at 41°C. and during servicing the maximum mixed water temperature can be 2°C above the recommended maximum set outlet temperature.

The mixed water outlet temperature must never exceed 46°C. For educational establishments the bathing temperature should not exceed 43°C. After commissioning, carry out the cold failure test to ensure the valve is operating correctly.

Testing Method

The valve should be tested to ensure correct operation at commissioning and thereafter at stated intervals decided by the user but never at greater than 12 monthly intervals.

The testing will only require a normal thermometer with a scale greater than 65°C. The temperature sensitive element of the thermometer should always be fully inserted into the water flow.

Measure the mixed water temperature. Carry out a cold fail/safe shut-off test by using the isolation valve to shut off the water to the cold supply.

Wait 5 seconds, if water is still flowing check that the water temperature is below 46°C. The flow should stop or reduce to a trickle. Open cold water isolation valve and measure mixed water temperature.

If there is no significant change from the original settings and fail/safe shut off is functioning the valve is working correctly and no further service is required.

If the outlet temperature has drifted by more than 2°C, or if the fail/safe function does not work, a full service or re-commissioning is required.

The manufacturer of this valve recommends that in these circumstances you contact him for advice as servicing should only be undertaken by competent persons.

If there is a residual flow during the commissioning or the annual verification (cold water supply isolation test), then this is acceptable providing the temperature of the water seeping from the valve is no more than 2°C above the designated maximum mixed water outlet temperature setting of the valve.

Water Supply (Water Fittings) Regulations 1999

This valve complies with the requirements of the above Regulations and installation should be carried out in strict compliance with them.

Aftercare

Crosswater thermostatic shower valves should be treated with care.

Do not use abrasive cleaners as this may cause damage. An occasional wipe with a soft damp cloth followed by a thorough rinsing is all that is required.

**ATTENTION**

If the collar is going to be changed then the number should be noted and kept safe as it will be required should you need to contact us in the future.

