

# ALCHEMY BRASSWARE

---



Sottini

## Installation Instructions

---

- E1950 Alchemy single lever basin mixer
- E1952 Alchemy dual control basin mixer with cross handles
- E1953 Alchemy dual control basin mixer with lever handles
- E1954 Alchemy dual control bath filler with cross handles
- E1955 Alchemy dual control bath filler with lever handles
- E1960 Alchemy single lever basin vessel mixer
- E1961 Alchemy wall mounted basin mixer with lever handles
- E1962 Alchemy wall mounted basin mixer with cross handles
- E1963 Alchemy floor mounted bath pillars
- E1964 Alchemy single lever bidet mixer
- E1965 Alchemy single lever bath filler

### INSTALLER:

After installation please pass this instruction booklet to user

## GENERAL NOTES

This installation instruction covers the Alchemy range of bathroom fittings both dual control and single lever.  
Pipework must be flushed and free from installation debris before connecting the fittings.

**The fittings covered by this installation and maintenance instruction should be installed in accordance with the water regulations published in 1999\*, therefore American Standard would strongly recommend that these fittings are installed by a professional installer.**

### FIXATION TO BASIN

The pop-up rod must be correctly positioned in the groove in the fitting body before putting the fitting into the tap hole. Ensure the seal (24) is seated correctly on top of the basin and the flexible horseshoe washer (23a) is placed in direct contact with the underneath surface of the vitreous china.

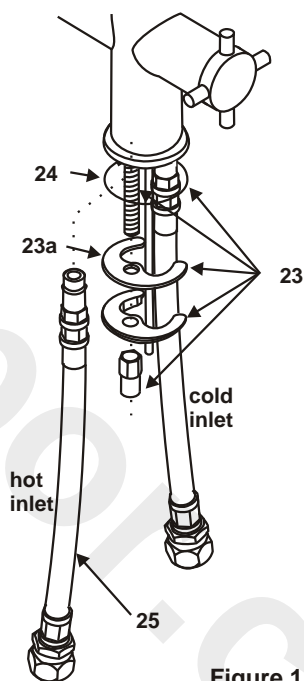

### IMPORTANT NOTE

All fittings covered by this instruction with the exception of the E1965 single lever bath filler have the hot connections on the left.

## INSTALLATION

Always flush water through the pipework to remove any debris before connecting the fittings.

### IMPORTANT NOTE

The one hole bath filler is designed for a corner installation (see Fig 1) or a position along the front side rim of the bath. Do not fit in line with the overflow assembly.

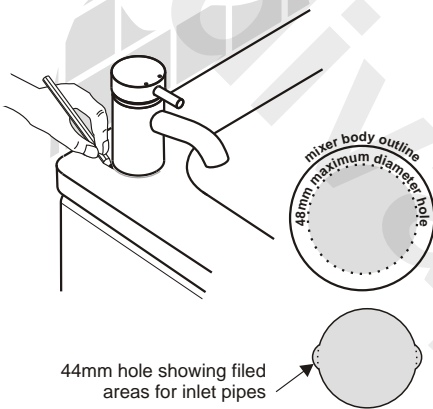

**Figure 2**  
Tap hole details for single lever bath filler E1965

The Alchemy monoblock bath fitting requires a bath supplied without tap holes. The installer will have to drill a 48mm diameter hole in the rim. Before this is done the following will have to be considered.

If located directly in line with the overflow (not recommended - see above) the pop-up waste may foul the under-parts of the fitting.

If a shower screen is to be fitted it could foul the fitting.

### NOTE

Although 48mm cutters are available from most manufacturers, they are not yet as commonly available at trade counters as other sizes. It is important if 'making-do' with a wrong size cutter to ensure that it not greater than 48mm.

e.g. A 1½" (44mm) cutter can be used and the hole filed out locally to accommodate the inlet pipes. (Figure 2)

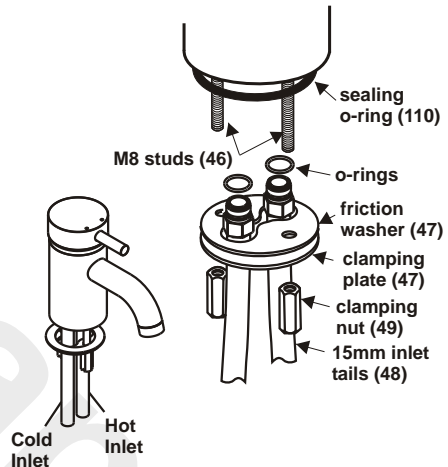

**Figure 3** S/L bath filler inlet tails

Before fitting the tails, offer up the bath S/L in the intended location and check for free movement of the lever. Draw a pencil line around the base (Figure 2)

In the center of the of the outline, drill the 48mm hole. (Figure 2)

Fit the supply tails (48) ensuring the O-rings are correctly located in the groove below the M18 threads. Place the sealing o-ring (110) in the groove on the underside of the fitting base.

Place the fitting concentrically in the new tap hole and ensure the sealing o-ring (110) is seated correctly on top of the bath. The clamping plate and friction washer (47) must be placed against the underneath surface of the bath tap deck. Tighten the sleeve fixation nuts (49) until the fitting is secure. (Figure 3)

## Wall mounted basin filler Installation

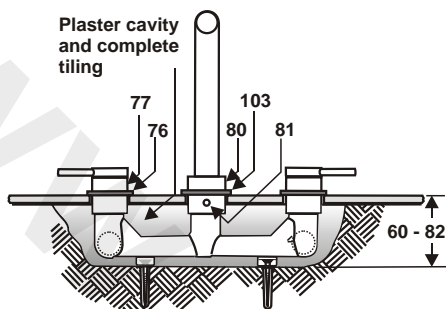

**Figure 4**

The built-in wall mounted basin mixer is suitable for solid or stud walls. In solid walls chase out a recess in the wall to a depth of 60 - 82 mm from the finished wall surface. In a stud partition wall fit a timber noggin at a suitable depth.

Screw the fitting body to the back of the recess or the noggin ensuring it is both horizontal and vertical. Connect to the supplies (hot on the left) using size G1/2 tap connectors.

Fit spout connector (102) to the body using thread sealing tape or traditional hemp and compound.

Push on the spout base (80) and secure with grub screw (81)

Test all connections before making good the cavity and completing the tiling.

Slide escutcheons (76 & 103) down the valve cover (77) and spout base (80) so that they cover the edge of the tiling.

## Worktop mounted basin filler

The Alchemy single lever vessel basin mixer is intended for use with a free standing basin of maximum height 158mm to enable the required 25mm minimum air gap.

If the correct air gap is not achievable then the basin filler must be connected using double check valves to protect against possible back flow. (Figure 5)

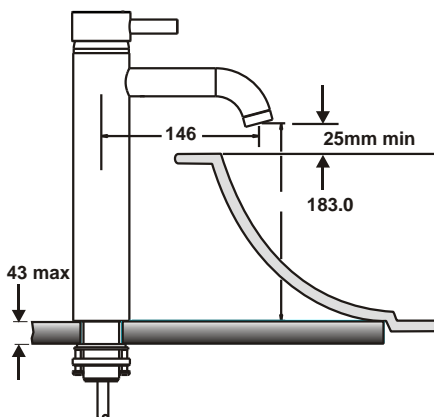

**Figure 5**

Drill a hole of diameter 35 mm in the worktop in the appropriate position.

Attach the fitting with the washers in the correct position. (Figure 6)

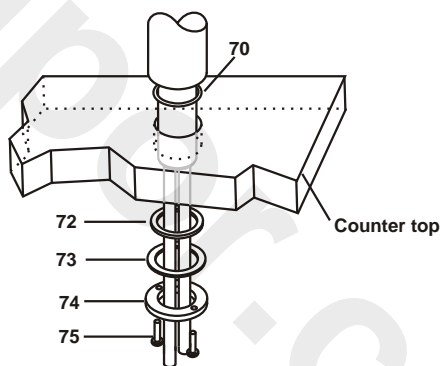

**Figure 6**

Tighten the lock nut (74) until it is hand tight.

Make the fitting secure by tightening the two pinch screws (75) against the slip washer (73).

Connect to the supplies using 10mm compression fittings.

### Floor mounted bath bridge filler

Assemble stand pipes to bridge mixer fitting as follows.

Remove the base escutcheons from the bath bridge mixer fitting. (Figure 16)

Connect threaded insert (83) (Figure 21) to the G $\frac{3}{4}$  tails of the mixer. Place the sealing washer (97) inside the insert and seal using thread tape or traditional hemp and compound.

Push-fit coupler end of stand pipe (84), on to the insert (83) and secure with grub screw (90). Fit blanking plug (93). (Figure 21) Repeat for second stand pipe.

To comply with back-syphonage requirements in the Water Regulations, it is essential to ensure there is an air gap of 25mm minimum between the bath filler spout and the spill over rim of the bath tub. As the fitting spout will be a fixed 737mm above floor level this means the bath tub must be set at a height no greater than 712mm above floor level.

Mark out the desired position for base flanges on the floor. Ensure these are positioned so that the backing washer (87) will not interfere with any joists.

The fitting/stand pipe assembly will only be as secure as the floor board(s) to which it is fixed. It may be necessary, therefore, to reinforce the floor by attaching transverse wooden boards underneath the fitting and screwing the adjacent floor boards to them. All the boards to which the transverse board is attached should be **SECURELY SCREWED** to the adjacent joists. (Figure 7)

Drill two 32mm diameter holes in the floor and reinforcing board. Fit the G $\frac{3}{4}$  tails through the holes and secure using the washer (87) and nut (92). The nut can be tightened using a 4mm tommy bar.

Make water connections using conventional tap connectors or compression nut (not supplied).

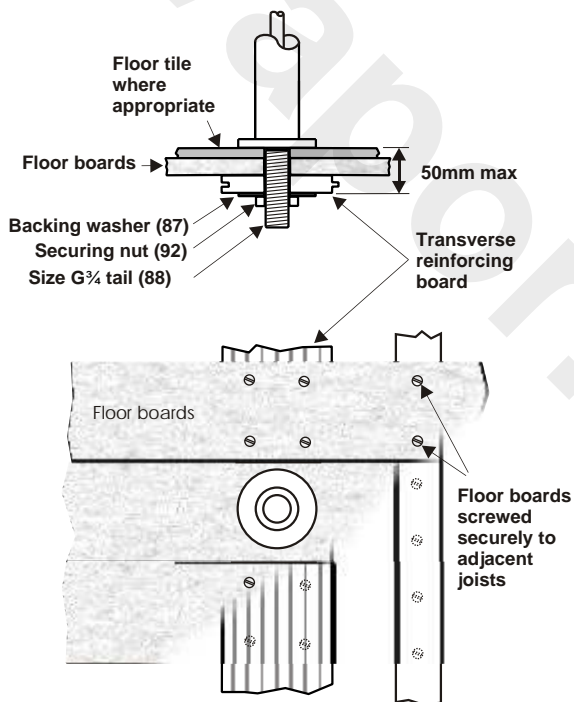
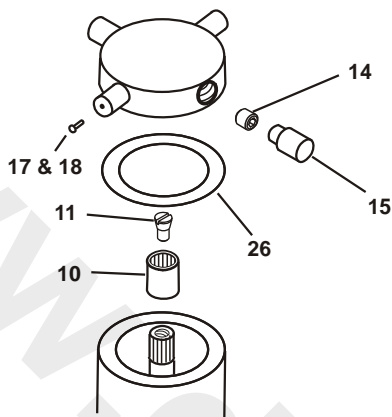

Figure 7



**Figure 8**  
Alchemy with cross head handle

One of the four pins (15) does not have a red or blue button in its end. This pin, which should only be hand tight, unscrews to give access to the handle retaining grub screw (14). Unscrew the grub screw using a 3mm A/F Allen key and the handle will pull off. (Figure 8)

**Tip:** When turning the pin (15) by hand it is sometimes difficult to apply enough friction. The use of pliers will normally damage the chrome plating. To overcome this, wind a broad rubber band or masking tape around the pin several turns before gripping it with pliers and it will unscrew easily and without damage.

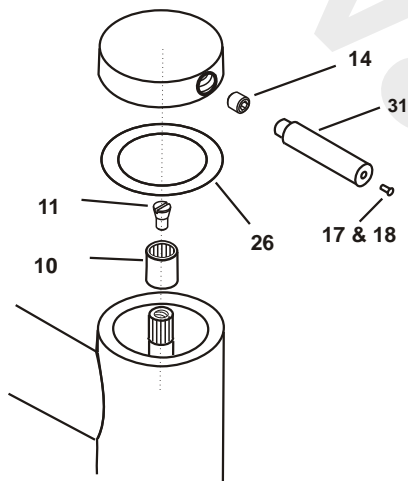

**Figure 9**  
Alchemy dual control with lever handle

Unscrew the lever (31) which should only be hand tight, to reveal the grub screw (14) which when undone using a 3mm A/F Allen key allows handle to be pulled off. (Figure 9)

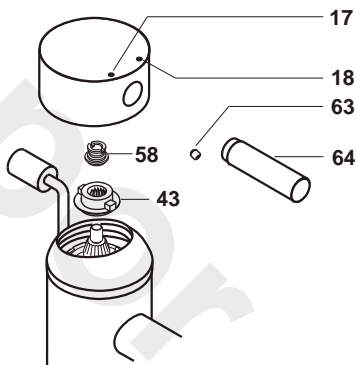

**Figure 10**  
Alchemy with single lever handle

The handle locates on the drive insert (43) and is tightened to the retaining nut (58) with the grub screw (63). To remove the handle unscrew the lever (64) - it should only be hand tight - to gain access to the lever fixation grub screw (63). This should be unscrewed using a 3mm A/F Allen key and the handle will pull off. (Figure 10)

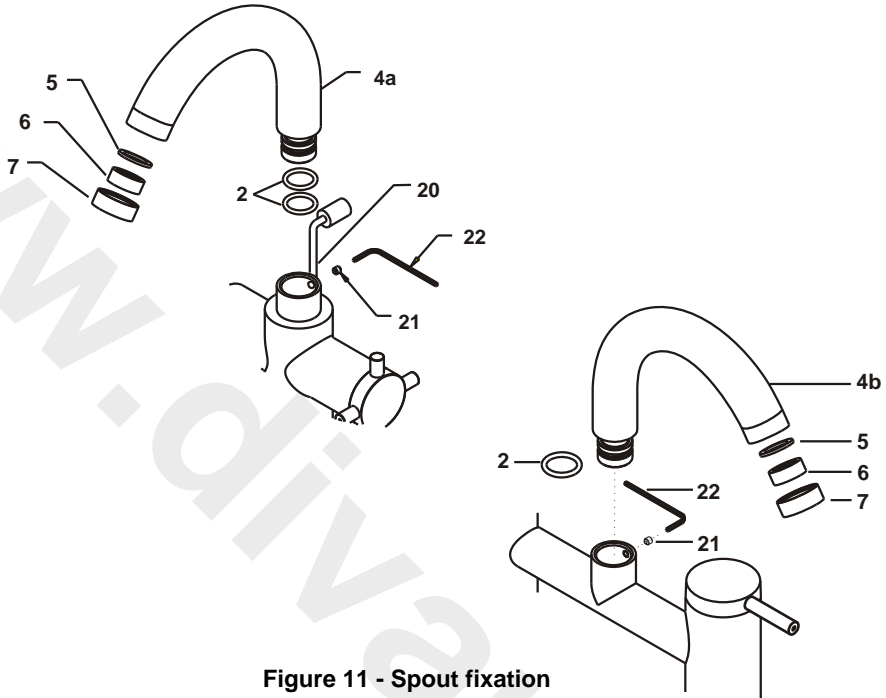

Figure 11 - Spout fixation

## SPOUT FIXATION

1. Ensure grub screw (21) is not projecting into the bore.
2. Engage the spout (4a/4b) into the body and push down until it is fully engaged.
3. Loosely tighten the grub screw using a 2mm A/F Allen key (22) and then unscrew half a turn to ensure free spout rotation.
4. The fitting is designed to have the grub screw facing away from the user in the installed position.
5. If it is preferred to have the spout in a fixed central position (e.g. for the bath filler), tighten the grub screw.

## INSTALLING ON HIGH PRESSURE

For use on high pressure systems it may be preferred to fit an aerator in place of the flow straightener (6) or (52). An aerator will reduce splashing and adds a luxurious feel to the water.

These parts (6a & 52a) may be ordered from customer care.

(See back cover for contact details)

### Quarter turn SE ceramic disc cartridges

The SE cartridge simply unscrews from the body using a 22 mm A/F deep socket or box spanner.

The stop plate may be repositioned to convert the rotation of the cartridge from clockwise to anticlockwise - or vice versa. To do this prise off circlip with a small screwdriver, lift and rotate the stop plate by 90°, and then refit the circlip. Figure 12

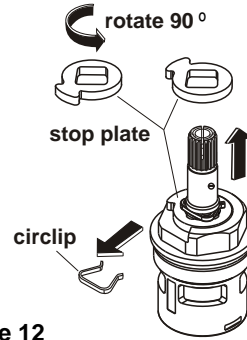
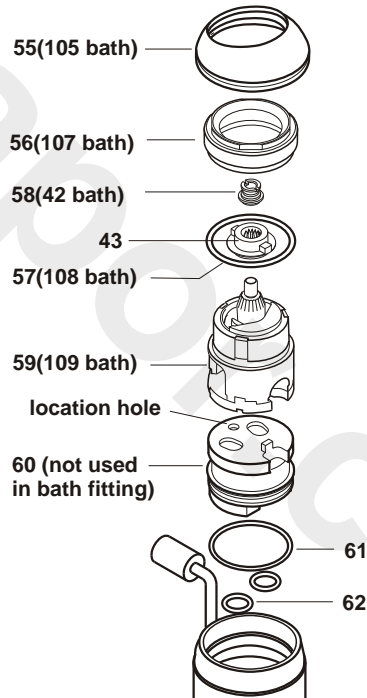

**Figure 12**  
Quarter turn cartridges ½ SE (8 & 9)  
& ¾ SE (33 & 34)

### Single lever Multiport cartridges

1. Remove lever handle (54/104) - see Fig 6.
2. Pull off shroud (55/38).
3. Unscrew cartridge retaining nut (56/107) and place on a clean piece of paper to ensure the grease on the o-ring does not pick up any grit.
4. Pull cartridge (59/109) out taking care not to disturb the position of the port adapter (60) in the case of the basin fitting.
5. Position replacement cartridge ensuring that the moulded location pin engages in the hole on the inside of the body or the port adapter in the case of the basin fitting.
6. Refit locking nut (56/107) and tighten. The ideal torque is 5 Nm. Typically this is hand tight plus ¼ turn. If over-tightened the cartridge will be stiff to operate and will have a limited life.

**Note: The bath cartridges, although they look similar to the basin cartridges, are constructed to give a higher flow rate and are therefore different.**



**Figure 13**  
Replacement of Multiport cartridge

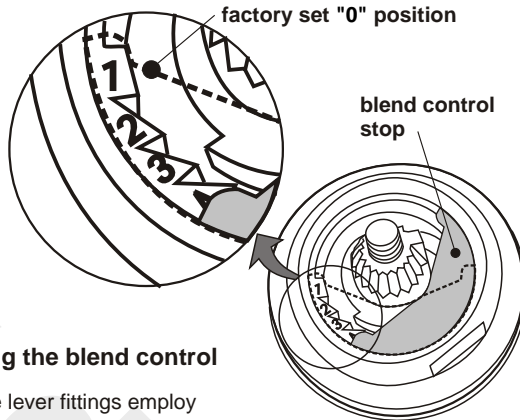

**Figure 14 Setting the blend control**

The Alchemy single lever fittings employ Multiport cartridges which have a blend control mechanism. This is a simple mechanical limit stop located under the single lever handle which restricts the angle to which the handle can be rotated towards the full hot position.

To set it, the hot water system should be on and the hot water up to normal working temperature. A thermometer will be required to measure the maximum blend temperature.

Remove the handle as previously described and pull off shroud. (Figure 13)

The blend control stop (white crescent shaped plastic moulding - shown shaded) can then be removed.

In its factory set position "0" - shown dotted in Figure 14 - it does not limit the lever handle

movement therefore the water temperature will be at its highest.

Insert the limit stop in position 4 - shown shaded in Figure 14.

Operate the fitting and measure the mixed water temperature at the maximum setting.

If not high enough, reposition the stop in position 3 and check the temperature again.

Repeat the process until the temperature at the maximum temperature position is satisfactory.

Refit the shield and handle and check that the maximum blend temperature remains unchanged.

## SAFETY FOR THE USER

The fittings are not thermostatically controlled and outlet temperatures depend on the position of the control handle, the hot and cold temperatures and pressures. If cold water supply fails for any reason, only hot water at its maximum temperature will be delivered.

Before using the handspray check that the temperature of the mixed water is satisfactory.

Young children, the elderly and infirm should be supervised when using the bath or handspray.

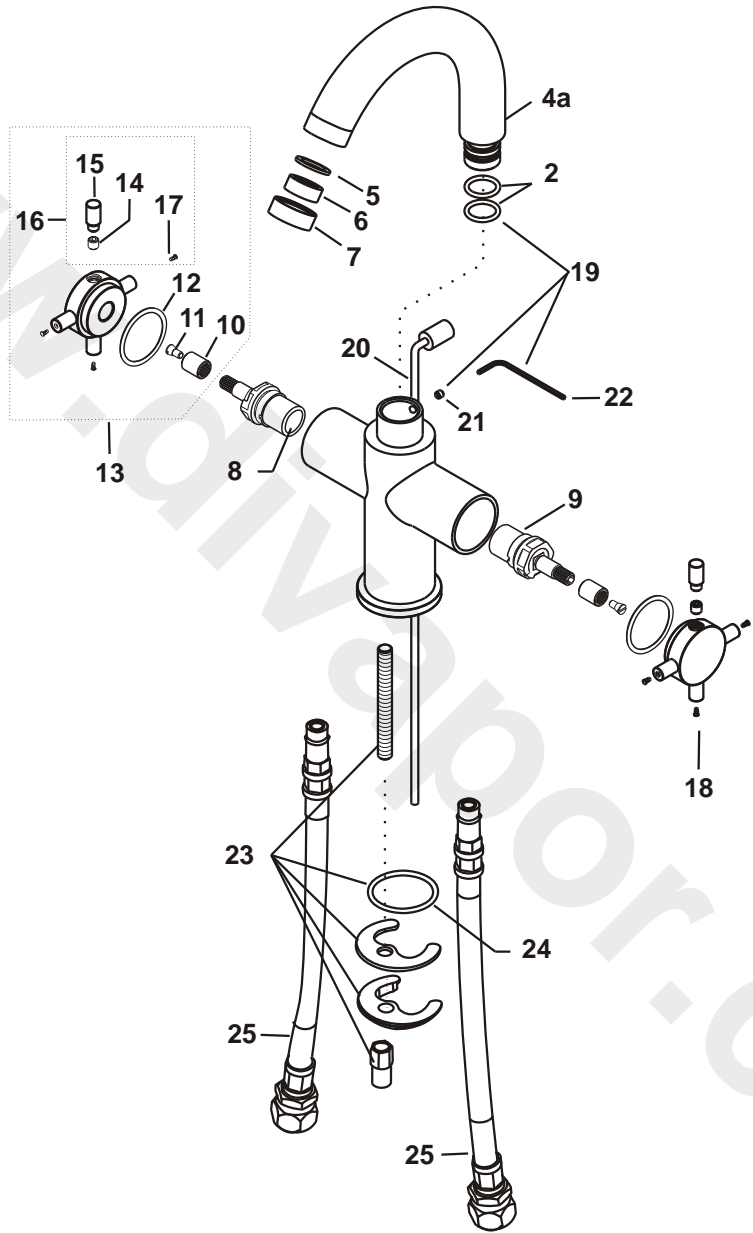

Figure 15  
ALCHEMY DUAL CONTROL BASIN MIXER (E1952 & E1953)

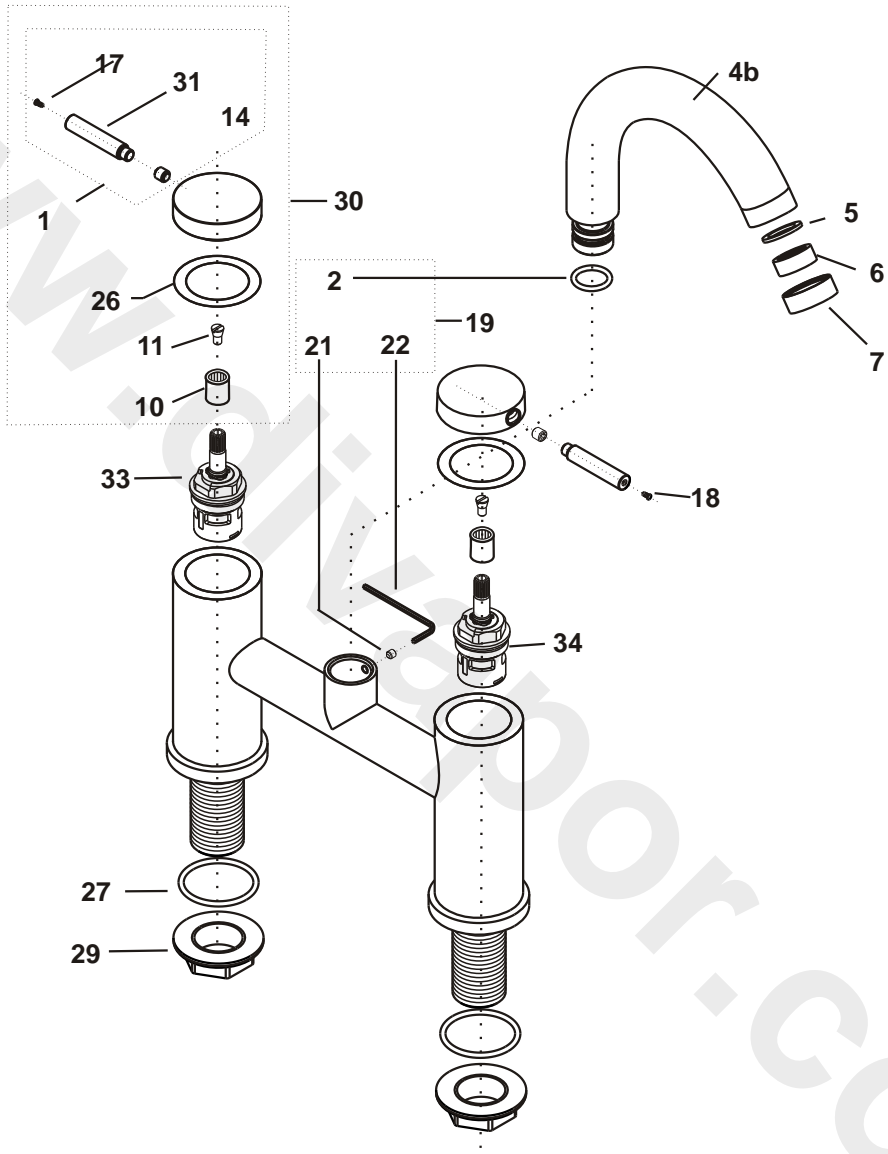
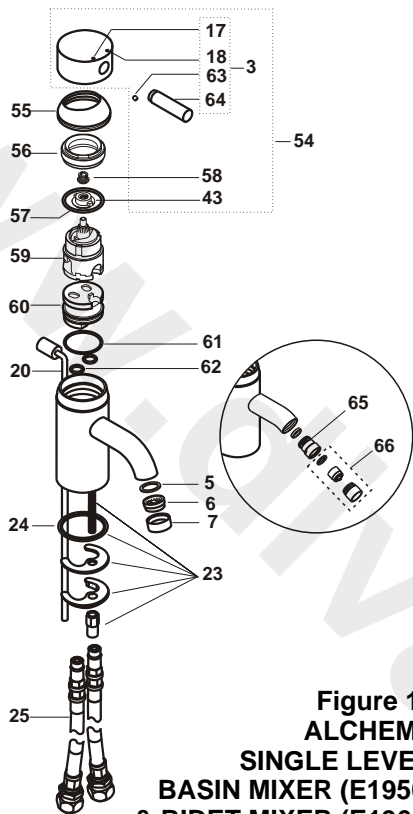
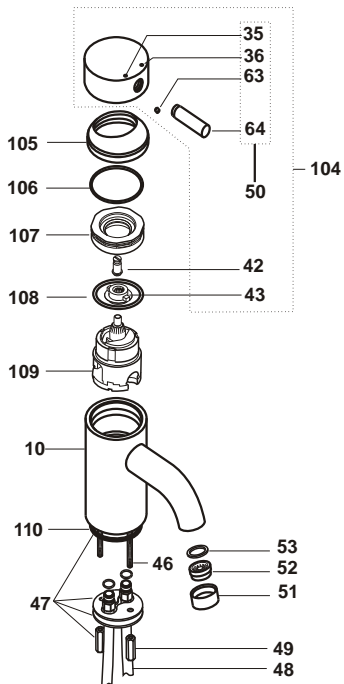

Figure 16  
 ALCHEMY DUAL CONTROL BATH MIXER (E1954 & E1955)



**Figure 17**  
**ALCHEMY**  
**SINGLE LEVER**  
**BASIN MIXER (E1950)**  
**& BIDET MIXER (E1964)**



**Figure 18**  
**ALCHEMY**  
**SINGLE LEVER**  
**BATH FILLER (E1965)**

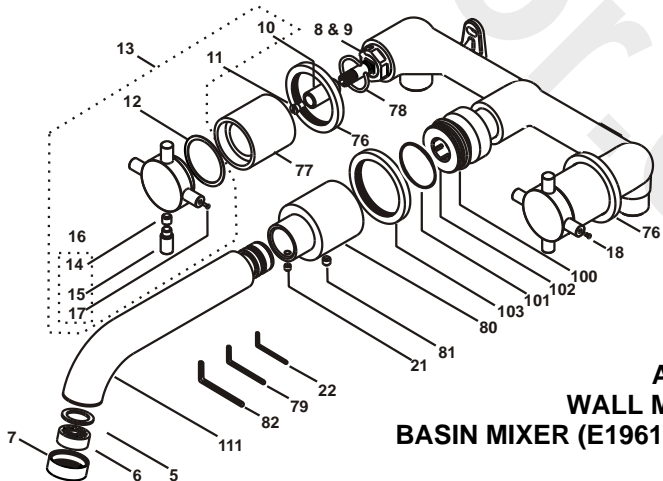

**Figure 19**  
**ALCHEMY**  
**WALL MOUNTED**  
**BASIN MIXER (E1961 & E1962)**

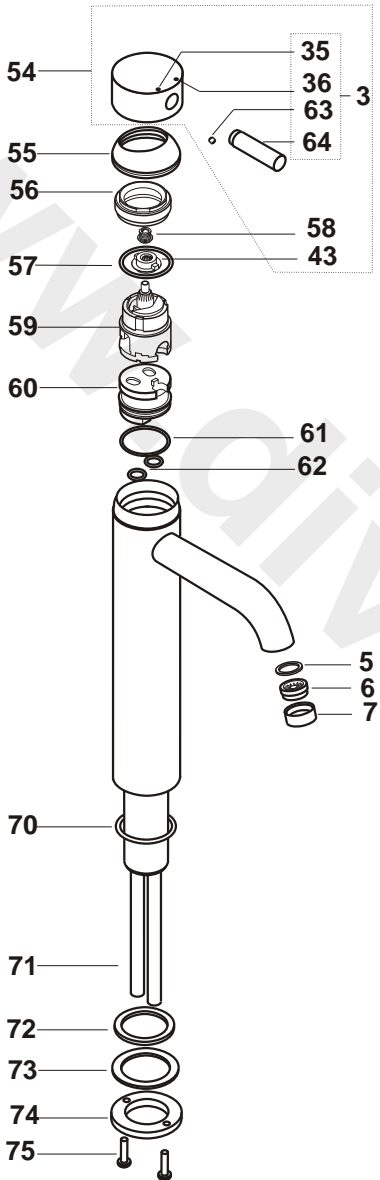

**Figure 20**  
**ALCHEMY SINGLE LEVER**  
**VESSEL BASIN MIXER E1960**

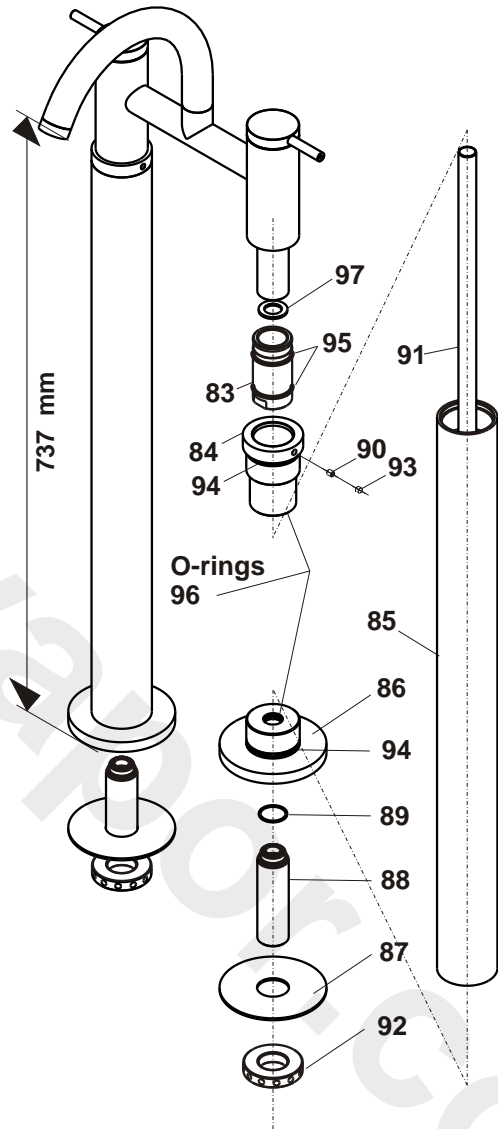

**Figure 21**  
**ALCHEMY FLOOR MOUNTED**  
**BATH BRIDGE FILLER**  
**(MIXER E1954 & E1955;**  
**PILLARS E1963)**

**Ref Description**

1	Quarter turn lever fixing kit
2	'O'-rings
3	Single lever pin kit
4a	Spout complete (basin)
4b	Spout complete (bath)
5	Rubber washer for flow straightener
6	23mm flow straightener
6a	Aerator kit for basin mixer (not supplied)
7	M24 flow straightener housing
8	½ SE ceramic disc cartridge - hot
9	½ SE ceramic disc cartridge - cold
10	Drive insert (splined)
11	Handle retaining screw
12	Handwheel bearing washer
13	Cross head handle complete
14	M6 x 6 grub screw
15	Blank cross head handle peg
16	Cross head handle fixation kit (14, 15, 17, & 18)
17	Index red
18	Index blue
19	Spout seal repair kit
20	Pop-up rod complete
21	M4 x 4 grub screw
22	2mm A/F hex allen key
23	Fixing kit
24	'O'-ring (base seal)
24a	'O'-ring (base seal)
25	Flexible inlet hose 300mm
26	Bath handle bearing washer
27	'O'-ring seal
29	G¾ backnut
30	Dual control lever handle complete
31	Dual control lever peg
33	¾ SE ceramic disc cartridge - hot
34	¾ SE ceramic disc cartridge - cold

**Ref Description**

42	Retaining nut
43	Drive insert
46	Long fixing studs (2)
47	Bath SL fixing kit
48	'O'-rings (inlets) (2)
49	Inlet tube assy (2)
51	Flow straightener housing
52	Flow straightener for S/L bath filler
52a	Aerator kit for S/L bath filler (not supplied)
53	Seal for flow straightener
54	Basin single lever handle complete
55	Shroud
56	Locking nut
57	'O'-ring seal (small multiport cartridge)
58	Retaining nut
59	Small multiport cartridge
60	Port adapter
61	'O' Ring for port adapter body
62	'O' Rings for port adapter base (2)
63	M4 grub screw for single lever
64	Lever peg for single lever handle
70	'O'-ring (base seal)
71	Inlet tubes (2)
72	Rubber washer
73	Slip washer
74	Lock nut
75	Screws M5x20mm
76	Side valve escutcheon
77	Valve shield
78	Shield spring ring
79	Allen key 2.5mm
80	Spout base
81	M5 x 5mm grub screw cup point

82	Allen key (3mm a/f)	96	'O'-ring 14.6 x 2.4 (seals - isolation tube)
83	Threaded connector sleeve	97	Flat fibre seal
84	Coupler	99	'O'-ring
85	Column outer tube	100	'O'-ring 28 x 3
86	Base flange	101	'O'-ring 39.6 x 2.4
87	Securing washer	102	Spout connector
88	G $\frac{3}{4}$ tail	103	Spout escutcheon
89	Copper sealing washer	104	Bath single lever handle complete
90	M5 x 6 grub screw with cup point	105	Shroud
91	Isolation tube	106	'O' Ring (shroud)
92	Securing nut	107	Locking nut
93	Blanking plug	108	'O'-ring seal (large multiport cartridge)
94	'O'-ring 39.5 x 3.0 (2)	109	Multiport cartridge HF
95	'O'-ring 27.6 x 2.4	110	'O'-ring deck seal S/L bath filler
		111	Spout complete (W/M Basin)

## MAINTENANCE

Alchemy fittings should be cleaned regularly using a mild detergent, rinsed with warm water and dried with a clean soft cloth.

The unique ceramic disc cartridges are built using ultra-smooth ceramic discs. These are so hard that they always remain sealed together, polishing each other in use. Sand, sediment and other water borne matter cannot get between them or damage them. Even the hardest water has no effect and this means

that the Alchemy fittings should give many years of efficient trouble free service without the drip and liming up problems associated with traditional valves.

However, in the unlikely event of a failure or any other problem it is a simple matter to exchange the cartridge. (Figure 13).

## CLEANING

When cleaning the fittings always use soap based cleaners. Never use abrasive or scouring powders and never use cleaners containing alcohol, ammonia, nitric acid, phosphoric acid or disinfectants.

# Sottini

Sottini  
The Bathroom Works  
National Avenue  
Kingston-upon-Hull  
HU5 4HS  
England

**CUSTOMER CARE HELPLINE**

**0870 129 6085**

**CUSTOMER CARE FAX**

**01482 499611**

**E-MAIL**

**[ukcustcare@aseur.com](mailto:ukcustcare@aseur.com)**

Sottini pursues a policy of continuing improvement in design and performance of its products.

The right is therefore reserved to vary specification without notice.

Sottini is a division of  
American Standard Plumbing (UK) Ltd

S279 10/05

E96503600