

inta

City

Vertical Shower Mixing Valves

CT60038CP & CT60014CP

Installation and Maintenance Instructions

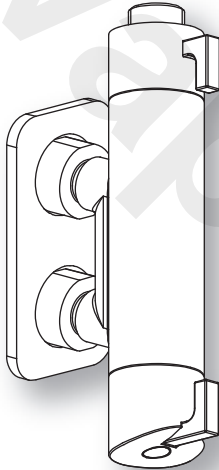

inta

Intatec Ltd

Airfield Industrial Estate

Hixon

Staffordshire

ST18 0PF

In this procedure document we have endeavoured to make the information as accurate as possible.

We cannot accept any responsibility should it be found that in any respect the information is inaccurate or incomplete or becomes so as a result of further developments or otherwise.

© Intatec Ltd. 2011

Tel: **0870 220 9666**

Fax: **0800 007 3157**

email: **sales@intatec.co.uk**

web: **www.intatec.co.uk**

Introduction

This installation guide has been produced for the City shower mixing valve. These instructions cover the installation, operation and maintenance. Please read the enclosed instructions before commencing the installation of this product, please note;

We recommend that the installation of any Inta product is carried out by an approved installer.

The installation must be carried out strictly in accordance with the Water Supply (Water Fitting) Regulations 1999 and any local authority regulations.

If in doubt, we would recommend that you contact either your local water authority, the secretary of the Water Regulations Committee at WRc on Tel: 01495 248454 or Institute of Plumbing on Tel: 01708 472791.

All products MUST be re-commissioned to suit site conditions to ensure optimum performance levels of the product are obtained.

Safety

This thermostatic shower mixing valve must be installed and commissioned correctly to ensure that water is supplied at a safe temperature to suit the users.

43°C is the maximum mixed water temperature from a shower mixer. The maximum temperature takes account of the allowable tolerances inherent in thermostatic shower mixers and temperature losses.

It is not a safe washing Temperature for adults or children.

The British Burns Association recommends 37 to 37.5°C as a comfortable washing temperature or children. In premises covered by the Care Standard Act 2000, the maximum mixed water outlet temperature is 43°C.

Products

City thermostatic in-line vertical shower with pole and overhead	CT60038CP
City thermostatic in-line vertical shower with flexible slide rail kit	CT60014CP
City thermostatic in-line vertical shower with bottom outlet	CT60010CP

Check Content

Before commencing remove all components from packaging and check each component with the contents list.

Ensure all parts are present, before discarding any packaging. If any parts are missing, do not attempt to install your Inta shower valve until the missing parts have been obtained.

Components

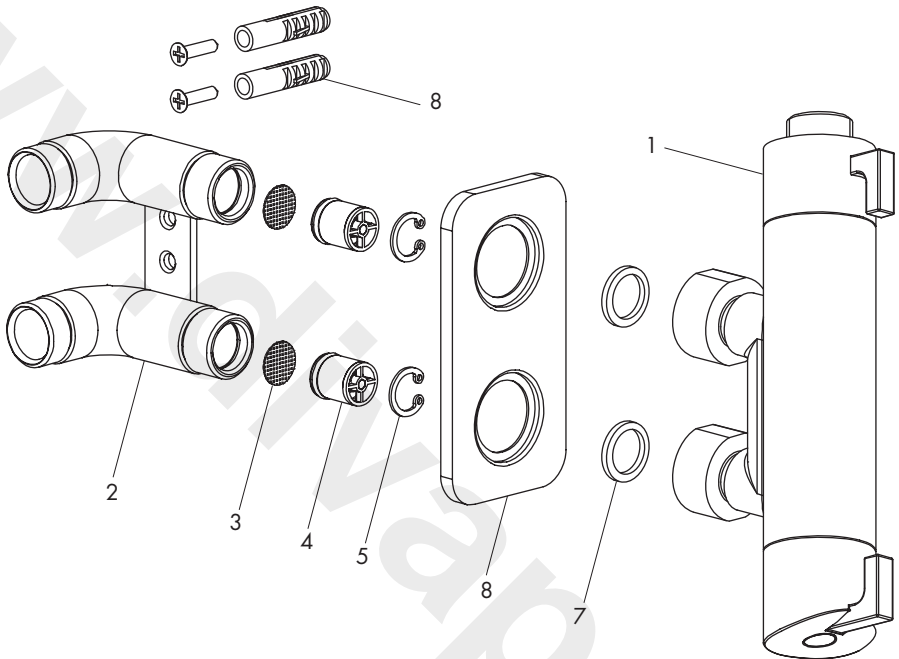

Item	Qty	Component
1	1	Shower valve
2	1	Mounting bracket
3	2	Check valve
4	2	Filter
5	2	Circlip
6	1	Concealing plate
7	2	Sealing washers
8	2	Screws and plastic wall plugs

Note: The filter, check valve and circlip are supplied fitted into the mounting bracket.

Technical Data

This City thermostatic shower valve is suitable for installations on all types of plumbing systems, including gravity supplies, fully pumped, modulating combination boiler, unvented water heater and unbalanced supplies i.e. Cold Mains & Tank Fed Hot. They are not suitable or non-modulating combination boilers.

Max Inlet Pressure (Static)	12 bar	Min Inlet Temperature	10°C
Max Inlet Pressure (Dynamic)	5 bar	Temperature Stability	±2°C
Min Operating Pressure (Dynamic)	0.4 bar	Min Temp Differential to	
Max Inlet Temperature	85°C	and cold supplies	15°C
Pre Set Factory Temp Setting	38°C	Inlet Connection - (Body only)	G½B
Max Unbalanced Pressure Ratio	10:1	Outlet Connection - top	G¾
		- bottom	G½

Unvented Mains Pressure System

The drawing shows a typical installation of a shower mixing valve in conjunction with an unvented hot water system. This type of installation must be carried out in accordance with Part G of the Building Regulations.

Whilst pressures are theoretically equal (balanced) most unvented hot systems have a pressure reducing valve on the incoming cold water prior to the hot water storage vessel. This means that the hot and cold pressures can be significantly different.

Most unvented systems use an inlet manifold located directly after the pressure reducing valve.

It is recommended that the cold supply be taken from one of the outlets of the manifold directly to the shower as an independent supply.

For systems without a manifold unit after the pressure reducing valve and where the cold water supply pressure is significantly higher than the hot supply we recommend that a separate pressure reducing valve is fitted to the cold supply, as close as possible to the shower valve and with no draw off points between it and the shower valve.

Flow regulators are required for installations where a PRV is not fitted to ensure simultaneous demand is accounted for.

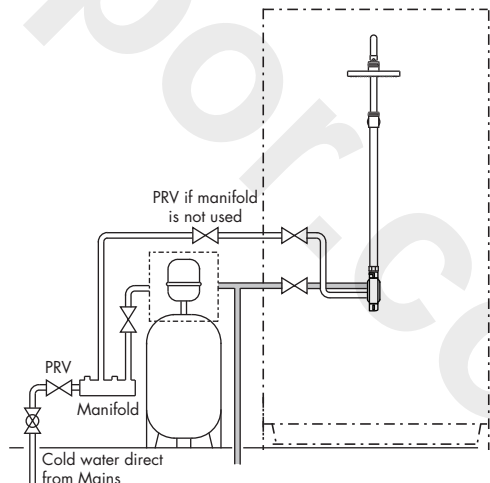

Pumped Systems

Pumped systems use a booster pump to increase the pressure of the gravity fed water supplies.

These booster pumps are used where the head of water is insufficient to provide a satisfactory shower or where a high performance shower is required.

Please ensure that the performance of the pump is matched to suit the shower.

Follow the instructions for gravity fed installations taking into account the installation requirements of the pump.

Ensure that the hot and cold water storage capacity is sufficient to supply the shower and any other draw off points that may be used simultaneously.

Most pumps require a minimum head of water to allow the flow switches to operate automatically. Where this is not available a negative head kit may be required to operate the pump.

Please consult the pump manufacturer's installation requirements

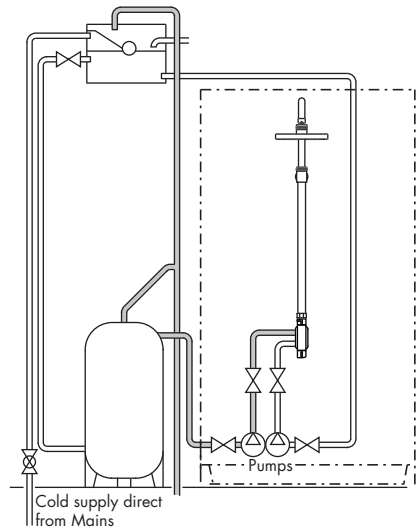

Modulating Combi Boiler / Instantaneous Gas Water Heater

The drawing shows a typical installation of a shower mixing valve in conjunction with a combination boiler.

Combi boilers will produce a constant flow of water at a temperature within its operating range. However we recommend that the system should supply hot water in excess of 60°C.

The hot water flow rates are dependant upon the type of boiler / heater used and the temperature rise required to heat the cold water to the required temperature.

The cold water flow rates may be much greater as they are generally unrestricted from the mains cold water supply. To ensure relatively balanced flow rates, we recommend that a pressure reducing valve or 6 l/min flow regulator is fitted in the cold water supply pipe (not supplied).

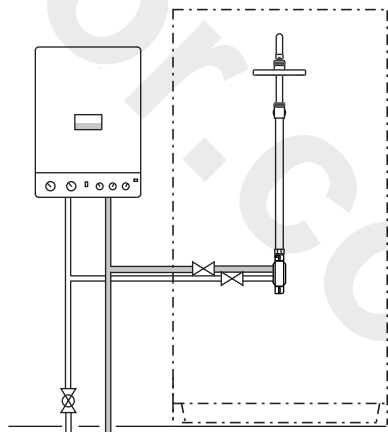

Gravity System

The drawing shows a typical installation of a shower mixing valve on a gravity supplied system.

Please note the minimum head pressure required to ensure correct operation of the valve. In accordance with good plumbing practice, we recommend that a totally independent hot and cold water supply be taken to the valve.

The cold water supply must be connected directly to the water cistern. The hot water supply should be connected to the hot water cylinder via an Essex flange or Sussex flange or to the vent or a draw off pipe as close as possible to the top of the cylinder.

For equal tank fed pressures there is no need to fit the flow regulators. This installation is the recommended minimum for gravity supplies. For systems with less than 2 metre head pressure, we recommend that a suitable booster pump is fitted to increase the supply pressure.

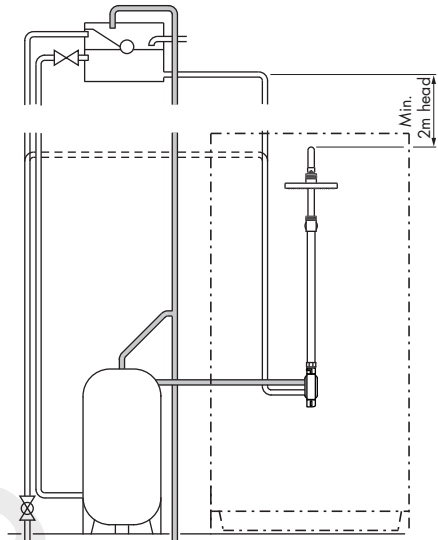

Cold Mains & Gravity Hot Supplies

If the cold supply to the shower is direct from the cold water mains and the hot water supply is gravity fed from the cold water cistern via the hot water cistern you **MUST** fit a pressure reducing valve or a 6 l/min flow regulator.

Site Preparation

It is important to plan the installation thoroughly to suit site conditions before commencing.

- Before commencing the installation ensure site conditions are suitable.
- Check there are no hidden electricity cables or water pipes before commencing.
- The City shower mixing valve is designed for concealed pipework, whether in a solid or studded wall.
- The thickness of wall tiles, plaster or plaster board should all be considered when positioning the mounting bracket and routing the hot and cold supply pipes.
- The supply pipes can come from below, above, the side or through the wall.
- BSP to compression fittings, angle tap swivel connectors or compression fittings can be used to connect the pipes to the mounting bracket.

Body Dimension

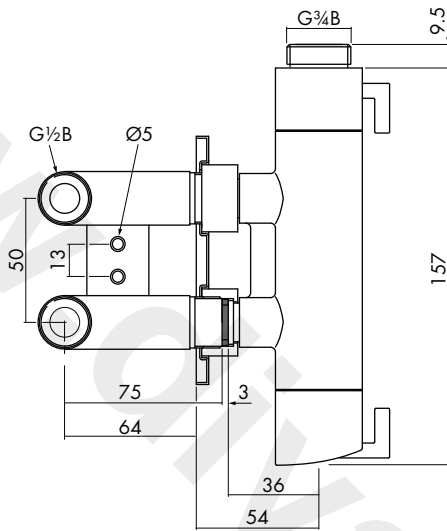

CT60038CP - Top Outlet

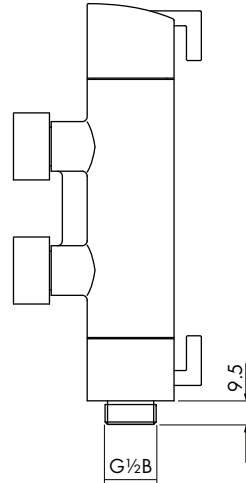

CT60014CP - Bottom Outlet

Installing the Mounting Bracket

- It is important to position the mounting bracket at the required height from the shower tray and depth within the wall.
 - The thickness of wall tiles, plaster or plaster board should all be considered but the two threaded connections for the shower valve should be approximately 11mm proud of the finished wall surface.
 - Ensure the bracket outlets to the shower are vertical.
 - The mounting bracket must be securely fixed either onto the masonry or onto a baton or noggin if mounted on a studded wall. The diagram shows a typical example for a studded wall finished with plaster board and wall tiles.
 - If installing the CT60038CP the HOT water supply is connected to the UPPER connection of the wall bracket when viewed from the front and the COLD water to the LOWER connection.
 - If installing the CT60014CP or CT60010CP the HOT water supply is connected to the LOWER connection of the wall bracket when viewed from the front and the COLD water to the UPPER connection.
- Note:** The hot and cold connections are marked on the shower valve but not on the bracket.
- The supply connections on the wall bracket are at 50mm centres.

Installing the Mounting Bracket

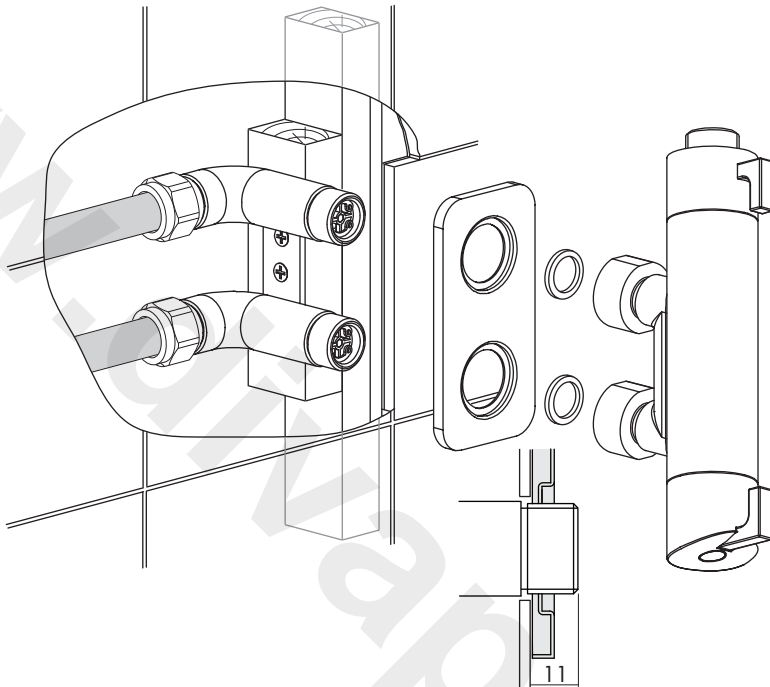

- Independent isolation valves, check valves and strainers should be fitted on both the hot and cold water supplies to the valve in an accessible position for ease of maintenance. Additional check valves may be required in certain circumstances to comply with the Water Regulations.
- Where possible on low pressure installations 22mm hot and cold supplies should be used close to the valve and that pipework runs should be as short as practically possible.
- We recommend that BS EN 1057 R250 (half hard) copper pipe is used.
- The supply pipes can come from below, above, the side or through the wall.
- If not embedded into the wall with plaster the pipes should be fixed securely to the studding.
- The whole system should be thoroughly flushed, prior to the connection of the hot and cold water supplies to the shower mixing valve, to remove any debris that may be in the supply pipework
- Ensure there are no joint leaks by temporarily fitting the shower valve and turning on the water supplies before finishing the wall.

Installing the Shower Valve

It is important to flush the supply pipework thoroughly prior to fitting the shower valve to prevent blockage or damage.

- When installing, care must be taken not to damage / affect the finish of this product.
- Seal the gaps between the threaded connections of the mounting bracket and wall surface with mastic.
- Place the concealing plate, with a bead of mastic around the back outer edge over the two connections and press firmly to the wall.
- The shower valve must be connected in the correct orientation. The HOT water inlet is identified by a RED dot and the COLD water inlet is identified by a BLUE dot.
- If installing the CT60038CP (top shower connection) the hot water is connected to the upper connection. If installing the CT60014CP or CT60010CP (bottom shower connection) the hot water is connected to the lower connection.
- Fit the shower valve to the wall bracket ensuring that the sealing washers are fitted and hand tighten the union nuts.
- The union nuts are intended to partly enter the recesses in the concealing plate.
- Ensure the shower valve is vertical when installed.
- Using a suitably sized spanner, tighten the union nuts taking care not to damage chrome finish, do not over tighten.

Installing the Fixed Shower

Fit the shower valve and finish tiling the wall prior to installing the shower riser.

Ensure that the outlet from the fixed shower will be over a suitable shower tray or bath.

Loosely assemble the locating adjuster and wall bracket.

Using the $\frac{3}{4}$ " sealing washer assemble the riser rail to the shower valve and position the locating adjuster/wall bracket onto the riser rail.

Locate the wall bracket onto the wall ensuring that the riser rail is vertical.

Mark round the wall brackets with a removeable marker onto the wall.

Remove the riser rail and the locating adjuster/wall bracket.

Position the wall bracket onto the wall within the markings and using the hole as a template, drill a 6mm diameter hole, if drilling into ceramic tiles use a ceramic bit.

To avoid cracking ensure the wall plug is pushed all the way behind the ceramic tile.

Using the screw provided secure the wall bracket firmly to the wall. This is the main fixing screw for the riser and shower so must be held secure by the plastic plug in the wall.

Installing the Fixed Shower Head

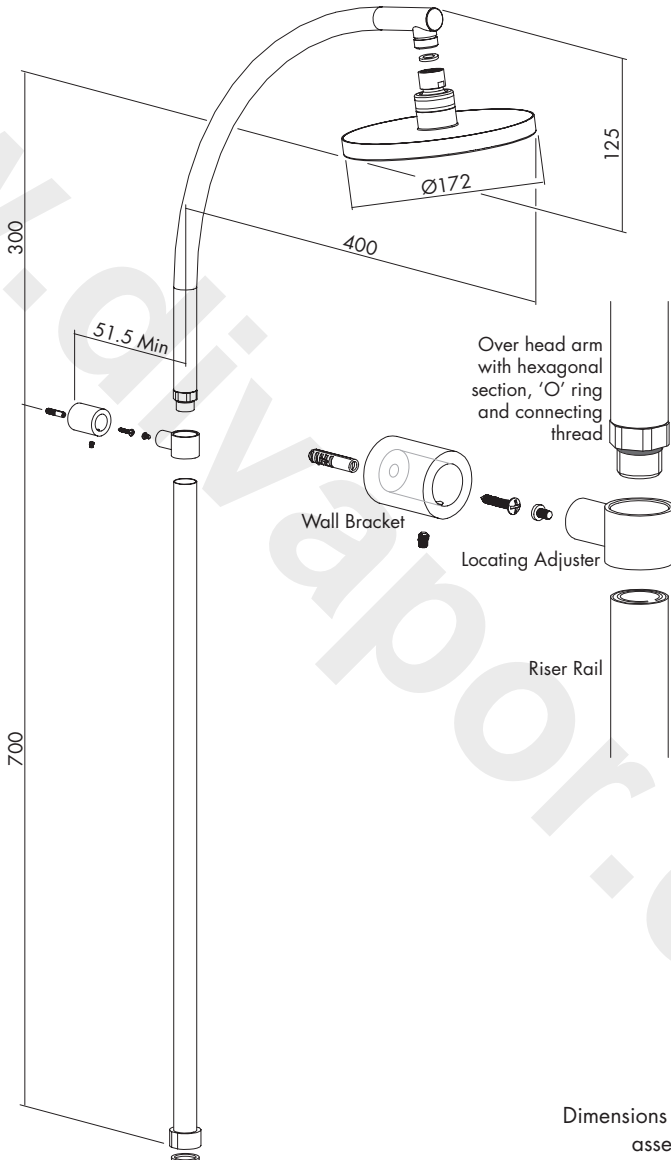

Assembling the Fixed Shower

If the wall is plaster board or soft building block use special wall plugs obtainable from most DIY stores.

Fit the fixed shower head to the arm using a $\frac{1}{2}$ " sealing washer and tighten the retaining nut to hold secure.

Locate the hexagonal section of the over head arm into the hexagonal hole of the locating adjuster ensuring the overhead arm will be in the correct position over the shower tray.

Locate the riser rail into the opposite hole of the locating adjuster and screw onto male thread of the overhead arm until tight.

Tighten the securing screw to hold the over head arm firmly to the locating adjuster.

Fit the shower rail assembly to the wall bracket and shower valve.

Tighten the $\frac{3}{4}$ " nut securing the riser rail to the shower valve to make a water tight joint.

Ensure the riser rail is vertical and the correct distance for the wall.

Tighten the grub screw to hold the assembly secure.

Turn on the water supply and check joints for leakage.

Installing the Flexible Handset

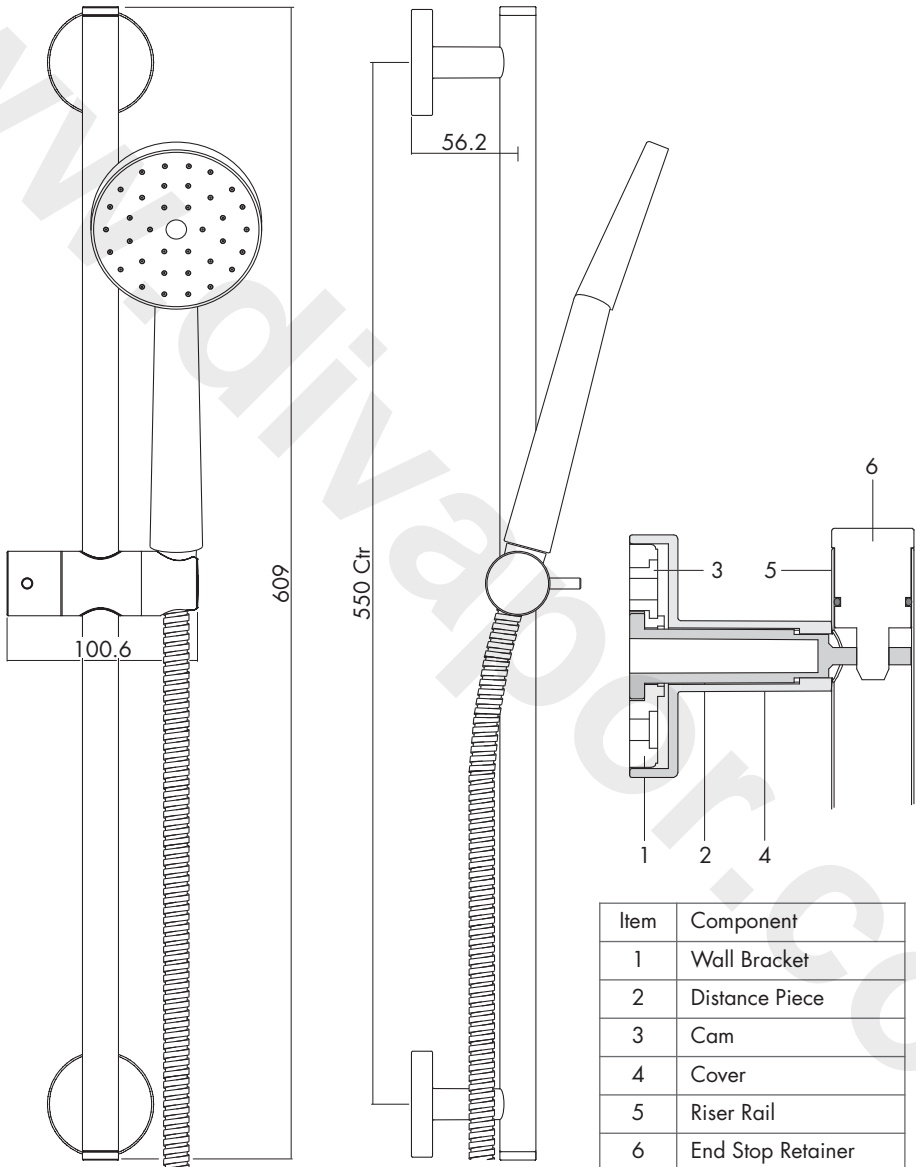

Installing the Riser Rail

The screws and wall plugs supplied are only suitable for use in solid walls. If the wall is plaster board or soft building block use special wall plugs obtainable from most DIY stores.

Ensure there are no supply pipes or cables where you intend to drill.

Where possible, drill holes between ceramic tiles (in the grout). If drilling into ceramic tiles use a ceramic bit.

This product must always be used and fitted in such a way as not to cause water damage, therefore should be located and directed towards a suitable bath or shower tray.

Take care to use power tools safely.

Locate the riser rail assembly onto the wall ensuring that the rail is vertical.

Mark round the wall brackets with a removeable marker onto the wall.

Remove the end stop retainers (6) from each end of the riser rail (5) and dismantle the wall brackets.

Position the wall bracket (1) onto the wall within the markings and using the holes as a template, drill two 6mm diameter holes, repeat for the second bracket.

To avoid cracking ensure the wall plugs are pushed all the way behind the ceramic tile.

Using the screw provided secure the wall plates (1) trapping the distance pieces (2) firmly to the wall. The position of the upper hole in each bracket can be adjusted by rotating the cam (3) to ensure the riser rail is vertical.

Ensure the flat section is horizontal for the end stop retainer (6).

Assemble the covers (4) to the wall brackets and the handset holder onto the riser rail.

Fit the riser rail (5) to the wall brackets and secure in place by pushing the end stop retainers into the ends of the riser rail, ensuring they are located into the distance piece.

Ensure the sealing washers are inserted into both ends of the flexible hose and connect the hose to the shower valve and the handset.

Turn on the shower valve and check joints for leakage.

Calibration

The Inta City vertical shower valve has a factory set outlet temperature of 38°C via the security setting. This is based on a balanced supply pressure and a stable hot water inlet temperature of 65°C.

However, the calibration point **MUST** be checked and re-set as necessary to suit site conditions.

Care must be taken when re-calibrating the valve as **INCORRECT CALIBRATION CAN CAUSE INJURY**.

CT60014CP with bottom outlet

- Remove the cover (2), retaining screw (3) and temperature control knob (4) by pulling away from the shower valve, and the temperature stop ring (5).
- Fully open the flow control knob (1) and allow the outlet temperature to stabilise.
- Temporarily refit the control knob (4) and using a digital thermometer it is possible to increase or reduce the mixed water outlet temperature until 38°C is re-established, by slowly rotating the control knob.
- Remove the control knob (4) and refit the temperature stop ring (5) onto the splined section of the cartridge. The red dot on the temperature stop ring must align with the temperature position symbol (9) on the valve body.
- Refit the temperature control knob in the reverse order ensuring that 38°C on the control knob is in line with the temperature position symbol (9).

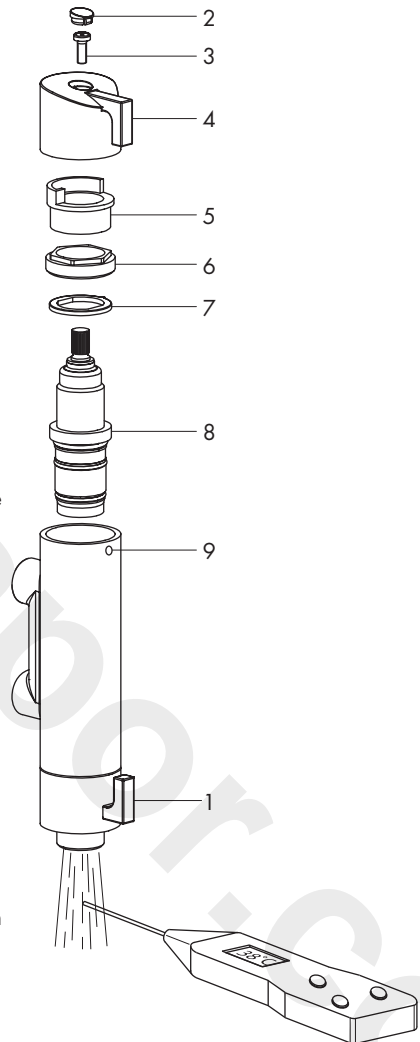

CT60038CP with top outlet

- Generally follow the procedure for the CT60014CP
- To measure the outlet temperature, remove the shower head from the fixed riser before opening the flow control knob (1).
- The water flow should remain in a constant stream allowing the temperature to be measured using a digital thermometer.

Cartridge Replacement

- Isolate both the hot and cold water supplies.
- Remove the cover (2), unscrew the retaining screw (3), remove the control knob (4) and temperature control ring (5).
- Using a suitably sized spanner unscrew the cartridge retaining ring (6) and the stainless steel washer (7).
- Carefully pull the thermostatic cartridge (8) out of the shower valve body.
- Replace with a new cartridge and assemble in the reverse order.
- When inserting the new cartridge take care not to damage the 2 'O' ring seals, lubricating with a WRAS approved silicon grease or washing up liquid will aid assembly.
- Refit the temperature control knob in the reverse order ensuring that 38°C on the control knob is in line with the temperature position symbol (9).
- The shower valve must be re-calibrated after fitting the new cartridge following the procedure above.

Aftercare

Inta vertical shower mixing valves have a high quality finish and should be treated with care.

An occasional wipe with a mild washing-up liquid on a soft damp cloth followed by a thorough rinsing is all that is required.

The nozzles in the hand set or overhead soaker should be cleaned periodically to remove any build up of debris or deposits which may affect the performance of the shower.

Do not use an abrasive or chemical household cleaner as this may **cause damage**.

Servicing

The Inta shower valve is designed to provide a high level of thermal performance to ensure the life cycle is as long as possible;

Valves should be serviced annually which should include the following:

- 1 Cleaning the independent inlet strainers - the filter element.
- 2 Cleaning the thermostatic cartridge filters - the complete cartridge must be removed for cleaning.

Fault Finding

Fault	Diagnosis
Showering temperature is not hot enough	Ensure the hot water supply is at a constant temperature above 60°C. Check for airlocks in the pipework
The water goes cold during showering	Insufficient stored hot water supply. If a combi boiler ensure it is still firing. Adjust the boiler control to a minimum setting of 65°C - not necessarily the best flow rate.
When the water is set at cold, the showering temperature is too hot	Hot and Cold supply connections have been reversed.
Maximum showering temperature is too hot or when set to hot the water runs cold	Check the commissioned maximum temperature of the valve. Check the connections to the valve are not reversed
Flow of water through the valve is low	Check the filters are clean and the supply pressure is above 0.4 bar
No flow of water	Check the valve has not fail-safed, and check that there is water flow to the valve and that the check valves are not closed - see Components illustration.

Please leave this Manual for the User