

BRISTAN

Chill Bath Shower Mixer

Fitting Instructions & Contents List



Please keep these instructions for future reference and request of replacement parts

Introduction

Thank you for choosing Bristan, the UK's leading taps and showers expert. We have designed this product with your enjoyment in mind. To ensure that it works to its full potential, it needs to be fitted correctly. These fitting instructions have been created to give you all of the information you need and, if you need any further help, please do not hesitate to give us a call on 0844 701 6273.

Safety Note

Please read these instructions thoroughly and retain for future use.

All product manufactured and supplied by Bristan are safe provided they are installed correctly, used correctly and receive regular maintenance in accordance with these instructions.

These fittings need to be installed in accordance with and meet the requirements of the Water Supply (Water Fittings) Regulations 1999 and Scottish Byelaws 2004.



Before starting any installation please consider the following:

Prior to drilling into walls, check that there are no hidden electrical wires, cables or water supply pipes. This can be checked with the aid of an electronic detector.

If power tools are used do not forget to:

- Wear eye protection
- Unplug equipment after use

Water Pressure

This mixer is suitable for use at all supply pressures. However for optimum use, both the hot and cold supplies should be reasonably balanced.

If the fitting is installed at low pressure (tank fed), the minimum height from the highest installed position of the showerhead to the underside of the cold water tank should be at least 1.0 metre (0.1Bar) to ensure adequate shower performance.

This mixer should be installed in compliance with water regulations. Where the supplies are unbalanced i.e. hot water from cylinder tank / cold from the mains, approved check valves must be fitted in the supply pipes.

For further information contact your local Water Authority.

Installation

1. Identify all components are present prior to installation.
2. Install the mixer body (1) to the bath, with the plinths (2) and foam washers (3) between the mixer and the bath, and the backnuts (4) below to secure it in position.
3. Connect the hot and cold water supplies.
4. Fit the hose (6) to the mixer (1) and the handset (8) using the small sealing washers (5).
5. Fix the wall bracket (7) to the wall using the screws and wall plugs provided, ensuring that the handset will reach its position.
6. Fully open both valves letting then run for a few minutes to check all joints and connections for leaks.
7. Operate the mixer in both bath and shower mode. To switch from bath to shower mode, pull the diverter knob up. After use the mixer automatically reverts to the bath filling mode.
8. See below for care instructions.

Note: This product does not incorporate a swivel spout and therefore cannot be rotated once installed.

Installation Diagram / Components

- | | |
|-----------------|-------------------|
| 1. Mixer Body | a. Handle |
| 2. Plinth | b. Indice |
| 3. Foam Washer | c. Spline Adaptor |
| 4. Backnut | d. Valve |
| 5. Hose Washer | |
| 6. Hose | |
| 7. Wall Bracket | |
| 8. Handset | |

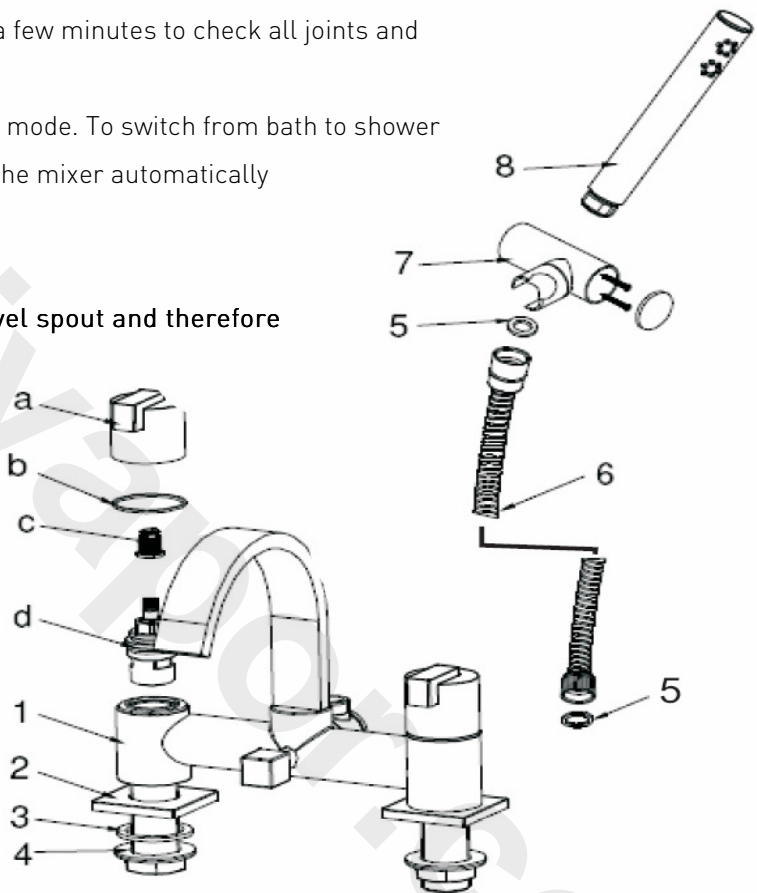

Maintenance

If the fitting begins to drip:

1. Turn off both water supplies.
2. Pull off handle (a)
3. Remove indice (b) and unscrew valve (d)
4. Carefully clean the valve, seating and seals.
5. Refit the valve and indice. Firmly push the handle back onto the spline of the valve.
6. Turn the water supplies back on.

If the problem persists contact our customer services helpline on 0844 701 6273.

Bristan recommend E-Cloth for cleaning all of our bathroom & kitchen products. Using just water, E-cloth gives a smear free, deep clean by breaking up and holding dirt, which normal cloths leave behind. Order through your Bristan stockist.

(ORDER CODE: ECLOTH)



Bristan Guarantee

Bristan offers solid guarantees to provide you with complete peace of mind.

Taps and Mixers

5 year parts and 1 year labour*. Gold painted and special finishes 3 years parts only.

All subject to proof of purchase.

Mixer Shower Valves

5 year parts. 5 year labour* (subject to registration), or 1 year with proof of purchase.

Gold painted and special finishes 3 years parts only.

Pumps and Power Showers

2 year parts. 1 year labour* (subject to registration).

Electric Showers/Instantaneous Water Heaters

2 year parts. 1 year labour* (subject to registration).

Accessories

5 year parts only. Includes bathrooms accessories, shower accessories (e.g. hoses, handsets and poles), wastes, WC levers and light pulls. Gold painted and special finishes 3 years parts only.

*Labour provided by an approved Bristan engineer. Guarantee only applies to products with a manufacturing fault. A deferred payment will be necessary in order to secure any visits by our engineers which will be charged if the problem is found **not** to be a manufacturing fault. If the fault is found to be down to a manufacturing error, the payment will be released and not charged.

This guarantee applies to products purchased within the United Kingdom or Republic of Ireland, but does not apply to products used commercially.

The guarantee is only available to original purchasers who have proof of purchase.

The installation must allow ready access to all products for the purpose of inspection, maintenance or replacement.

Any part found to be defective during the above guarantee period will be replaced without charge, providing that the product has been installed in accordance with the instructions, used as intended, and regularly serviced.

Servicing should be carried out at regular intervals of no more than 12 months and more frequently in hard water areas (heavy lime scale) areas.

In the unlikely event that any problems are encountered with the product's performance on installation, you must obtain guidance/authorisation from our Customer Service Department, and be able to supply proof and date of purchase, before any remedial action is taken.

The guarantee excludes general wear and tear and damage caused by accident, misuse or neglect, and does not cover the following:

- Components that are subject to general wear and tear such as filters, seals, 'O' rings and washers etc.
- Damage caused by faulty installation
- Damage caused by lime scale or any waterborne debris
- Damage caused by inappropriate cleaning products (see user instructions)
- Damage caused by the use of non-Bristan parts
- The product being used for a purpose other than intended by the manufacturer.

In the interests of continuous product improvement Bristan reserves the right to alter specification as necessary.

If your product is out of its guarantee period, or you would like to extend the guarantee, then please see our [extended warranty offer](#).



Guarantee

This booklet covers product code

CL BSM C

Helpline

0844 701 6273

Bristan Group Limited

A Masco Company

Birch Coppice Business Park, Dordon, Tamworth, Staffordshire B78 1SG

Website: www.bristan.com

Telephone: 0844 7016 274

Facsimile: 0844 701 6275

Email: enquire@bristan.com



Guarantee