

BRISTAN

Choices Sink Mixer

Fitting Instructions & Contents List

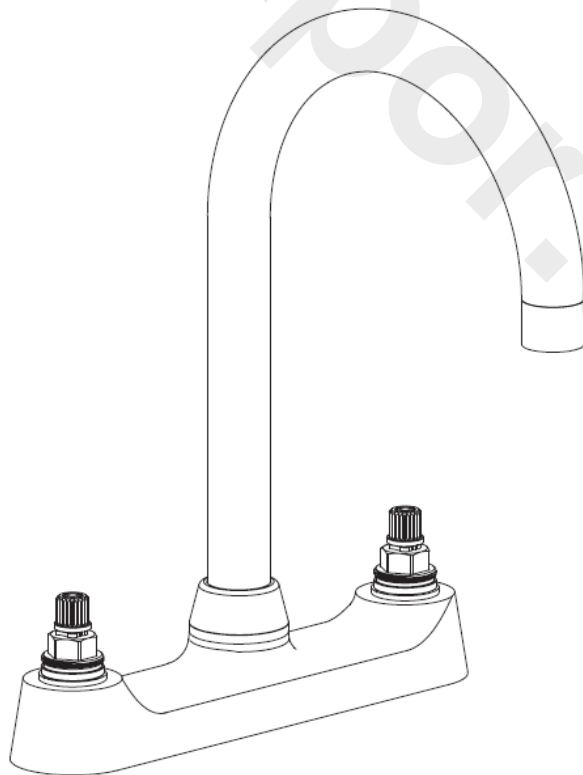

Please keep these instructions for future reference

Important Safety Information

- Please read these instructions thoroughly and retain for future use.
- All products manufactured and supplied by Bristan are safe provided they are installed correctly, used correctly and receive regular maintenance in accordance with these instructions.
- If you are in any doubt about your ability to install this product safely you must employ the services of an experienced qualified plumber.
- Remove all packaging and check the components for damage before starting installation.
-  Before starting any installation please consider the following: Prior to drilling into walls, check that there are no hidden electrical wires, cables or water supply pipes. This can be checked with the aid of an electronic detector.
- If power tools are used do not forget to:
 - Wear eye protection
 - Unplug equipment after use
- This product **must** not be modified in any way as this will invalidate the guarantee.
- These fittings need to be installed in accordance with and meet the requirements of the Water Supply (Water Fittings) Regulations 1999 and Scottish Byelaws 2004.

General Specifications

Operating pressure range (bar)	Min	Max
High Neck Taps	0.2	7.0
Sink Mixer	0.2	7.0
Deck Sink Mixer	0.2	7.0

Maximum static pressure – 10.0 bar

NOTE:- Nominally equal (balanced) inlet supply pressures are recommended for optimum Performance of mixer taps.

Designed to comply with BS EN 200 for single taps / combination taps for water systems of type 1 and 2 general technical specifications; and to be used within systems designed to BS 6700.

BS 6700 recommends the temperature of stored water should never exceed 65°C. A stored water temperature of 60°C is considered sufficient to meet all nominal requirements and will minimise the build up of lime scale in hard water areas.

IMPORTANT - PLEASE READ

This fitting needs to be installed in accordance with the following Installation Requirements and Notes (IRN) to ensure they meet the requirements of the Water Supply (Water Fittings) Regulations 1999 and the Scottish Byelaws 2004.

IRN R001

See text of entry for Installation Requirements or Notes.

IRN R006

This tap or combination tap assembly has a Type AUK3 air gap and is therefore for installation in any premises to protect against a backflow risk up to a Fluid Category 5.

Dimensions

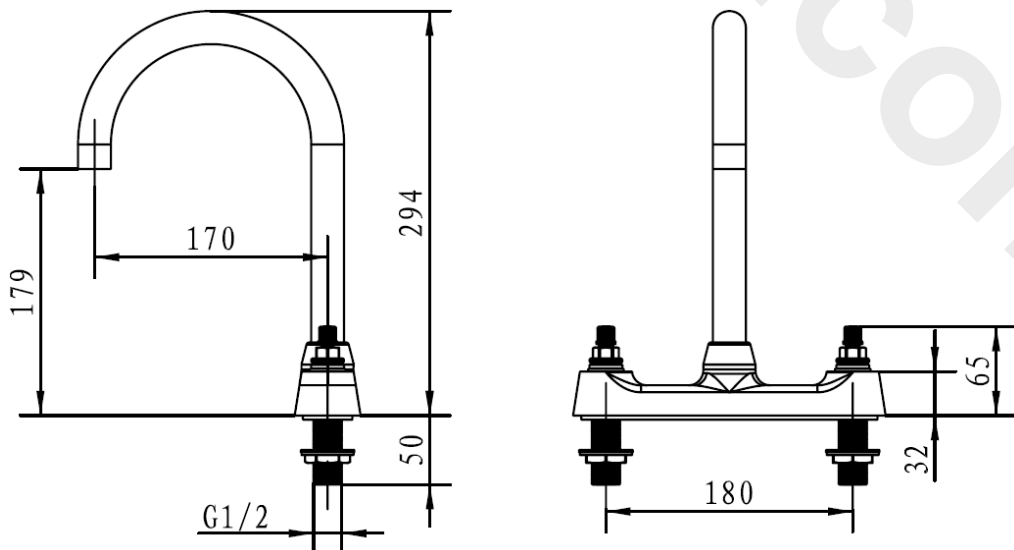
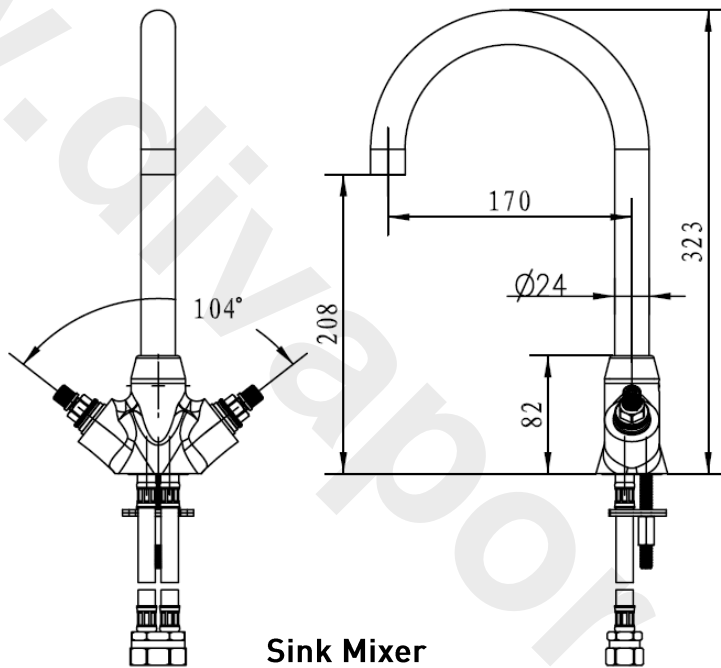

Installation

1. Identify all components are present prior to starting installation. Handles are not supplied with this product. Please visit www.bristan.com to view our range of Choices compatible handles.
2. Ensure that the O-ring (4) is fitted to the base of each tap body for fitting to the basin/bath.
3. Using the washer (5) and backnuts (6), secure the taps to the sink/work surface by tightening the backnuts onto the threaded tails. A suitable spanner may be required.
4. Connect the hot and cold water supplies to the taps.
5. Fit handles (not supplied) and turn on the water supplies. Open both taps letting the water flow for a few minutes to check all joints and connections for any leaks.

1.	Spline Adapter	x2
2.	Valve	x2
3.	Anti-Splash Assembly	x2
4.	O-Ring	x2
5.	Washer	x2
6.	Backnut	x2

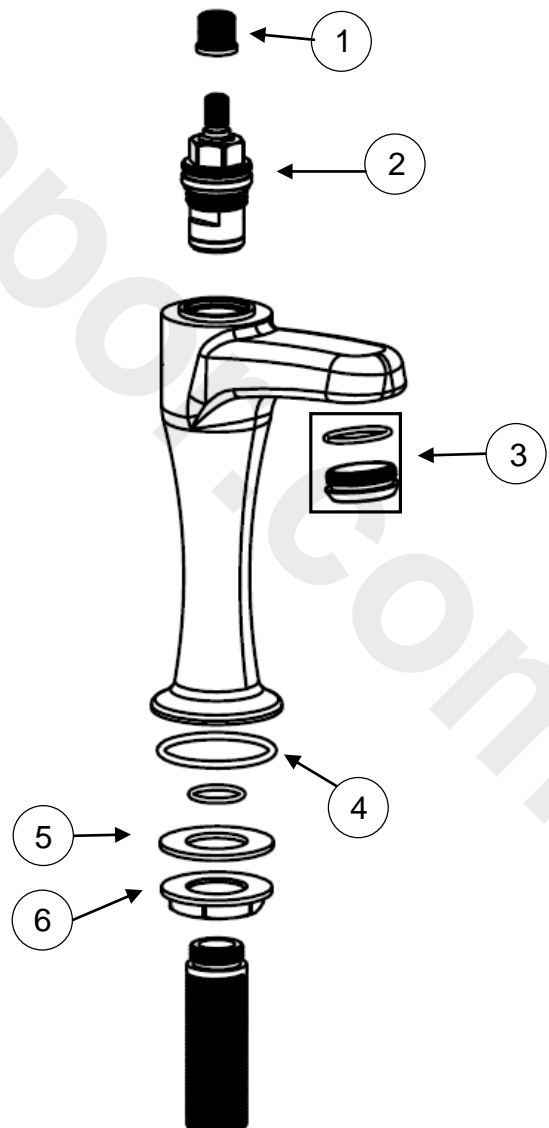

Installation cont.

Monobloc Sink Mixer

1. Identify all components are present prior to starting installation using the diagram overleaf. Handles are not supplied with this product. Please visit www.bristan.com to view our range of Choices compatible handles.
2. Fit the tap body (3) to the basin ensuring the o-ring (8) is fitted between the base of the tap body (7) and the sink/work surface (3).
3. Make sure that the fixing rod (11) is screwed fully into the base of the tap body (7)
4. Fit the 'C' shaped rubber washer (9) and the 'C' shaped metal plate (10) to the underside of the sink; and screw the backnut (12) to the bottom of the fixing rod (11) as tight as possible, using a suitable spanner.
5. Screw in the flexible connecting pipes (13) to the mixer (**DO NOT OVERTIGHTEN**) and connect the hot and cold water supplies.
6. Fit handles (not supplied) to the tap body and turn in both directions, letting the water flow for a few minutes to check all joints and connections for any leaks.

- | | | |
|-----|---------------------------|----|
| 1. | Spout | x1 |
| 2. | Grub Screw | x1 |
| 3. | Anti Splash Assembly | x1 |
| 4. | Spout Connection Assembly | x1 |
| 5. | Spline Adapter | x2 |
| 6. | Valve | x2 |
| 7. | Tap Body | x1 |
| 8. | O-Ring | x1 |
| 9. | 'C' Shaped Rubber Washer | x1 |
| 10. | 'C' Shaped Metal Plate | x1 |
| 11. | Fixing Rod | x1 |
| 12. | Backnut | x1 |
| 13. | Flexible Connecting Pipes | x2 |

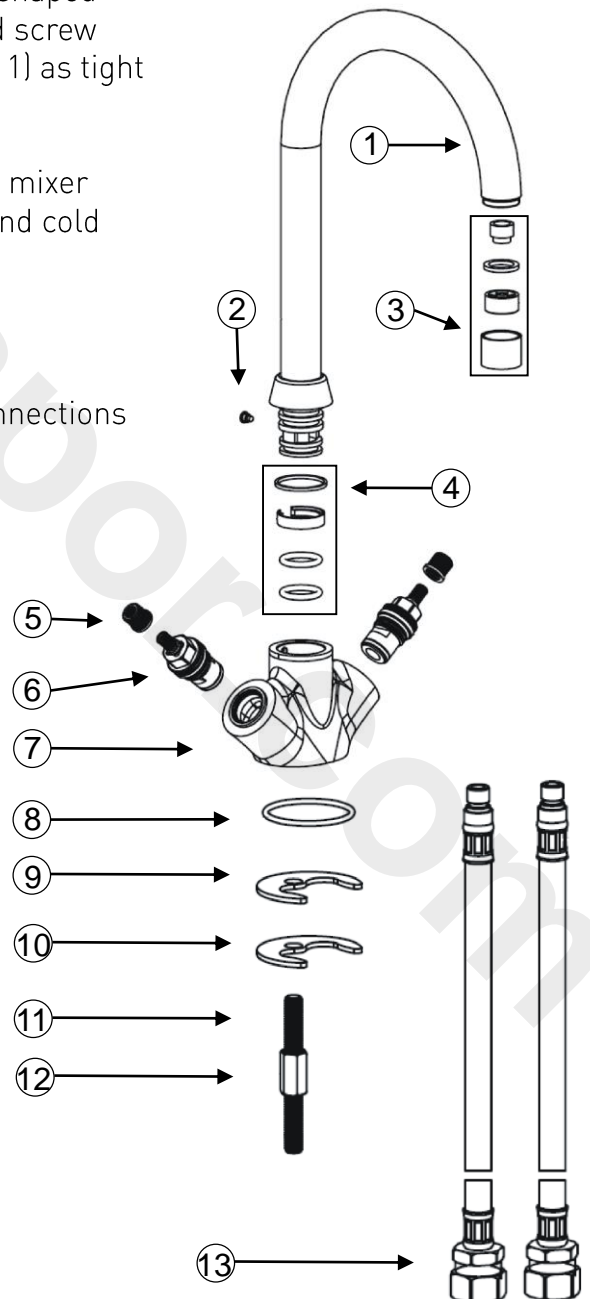

Installation cont.

Monobloc Sink Mixer

1. Identify all components are present prior to starting installation using the diagram overleaf. Handles are not supplied with this product. Please visit www.bristan.com to view our range of Choices compatible handles.
2. Fit the tap body (7) to the sink/work surface ensuring that the base washer (8) is fitted between the base of the tap body (7) and the sink/work surface.
3. Using the washer (5) and backnuts (6), secure the taps to the basin/bath by tightening the backnuts onto the threaded tails. A suitable spanner may be required.
4. Connect the hot and cold water supplies to the taps.
5. Fit handles (not supplied) and turn on the water supplies. Open both taps letting the water flow for a few minutes to check all joints and connections for any leaks.

1.	Spout	x1
2.	Grub Screw	x1
3.	Anti Splash Assembly	x1
4.	Spout Connection Assembly	x1
5.	Spline Adapter	x2
6.	Valve	x2
7.	Tap Body	x1
8.	Base Washer	x1
9.	Washer	x2
10.	Backnut	x2

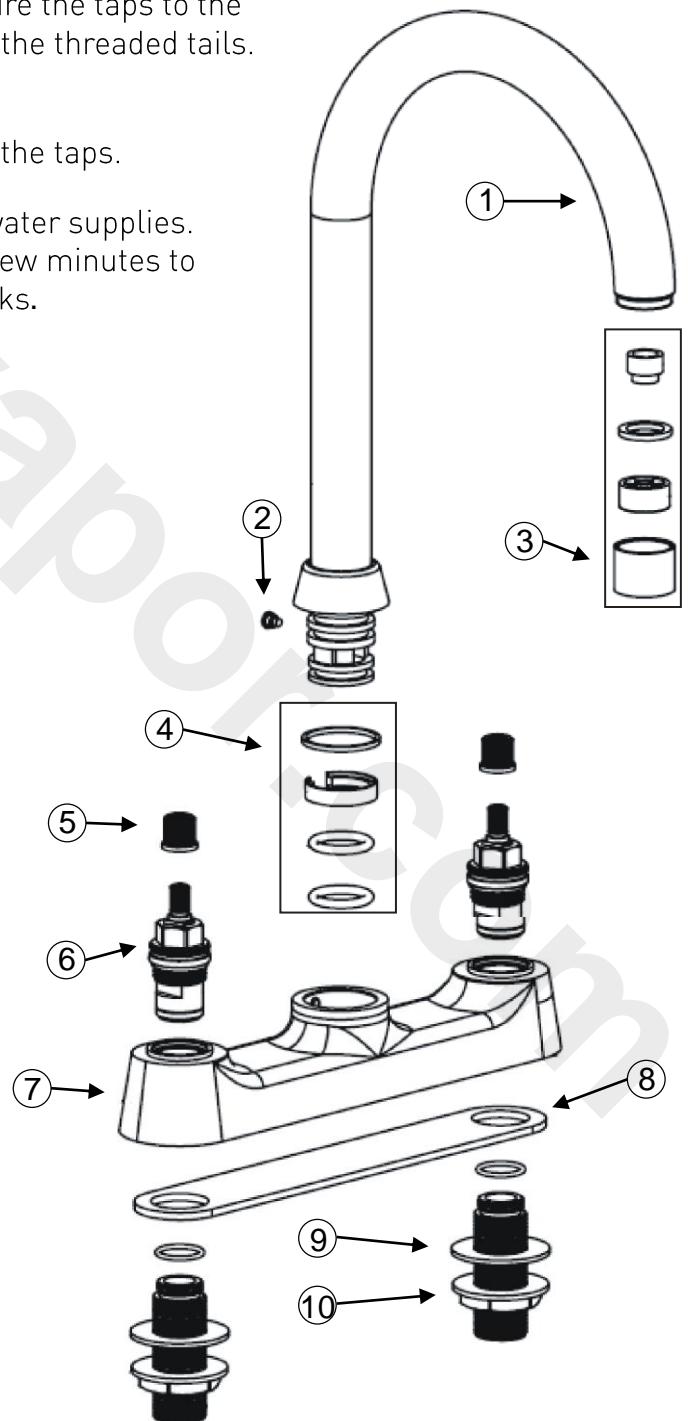

Maintenance

General Cleaning

Your fitting has a high quality finish and should be treated with care to preserve the visible surfaces. All finishes will wear if not cleaned correctly. The only safe way to clean your product is to wipe with a soft damp cloth. Stains can be removed using washing up liquid. All bathroom cleaning products (powders and liquids) will damage the surface of your fitting, even the non-scratch cleaners.

Note: Never use abrasive detergents or disinfectants or those containing alcohol, hydrochloric acid or phosphoric acid.



Bristan recommend E-cloth for cleaning all of our bathroom & kitchen products. Using just water, E-cloth gives a smear free, deep clean by breaking up and holding dirt, which normal cloths leave behind. Order through your Bristan stockist (order code: E-CLOTH).

We advise that your fitting is regularly serviced in hard water areas to maintain optimum performance.

If your fitting begins to leak the following should be carried out;

Isolate both hot and cold water supplies to the tap by either:

- Turning the water supply off at the mains stopcock or
 - Turning off the isolation valves to the tap.
1. Remove the handle (not supplied) to reveal the concealed spline adapter.
 2. Using a suitable spanner remove the valve from the tap body.
 3. Clean the valve and the seating inside the tap body.
 4. If necessary replace the valve.

Please visit www.bristan.com/sparesfinder in order to find spare parts for this product.

6. Replace the valve into the tap body and tighten fully using a suitable spanner.
7. Replace handle assembly.
8. Turn on water supply and check for leaks.
9. Contact our helpline should if problem persists.

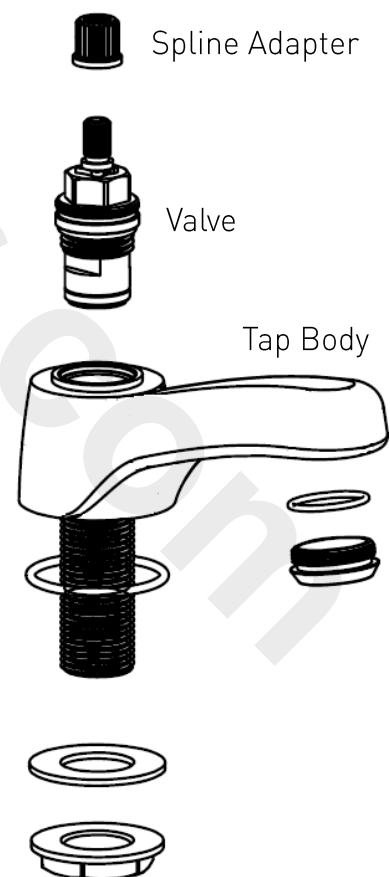

Map of Hard Water Regions in the UK



Soft to moderately soft
0 - 100mg/l as calcium carbonate equivalent



Slightly hard to moderately hard
100 - 200mg/l as calcium carbonate equivalent



Hard to very hard
Above 200mg/l as calcium carbonate equivalent

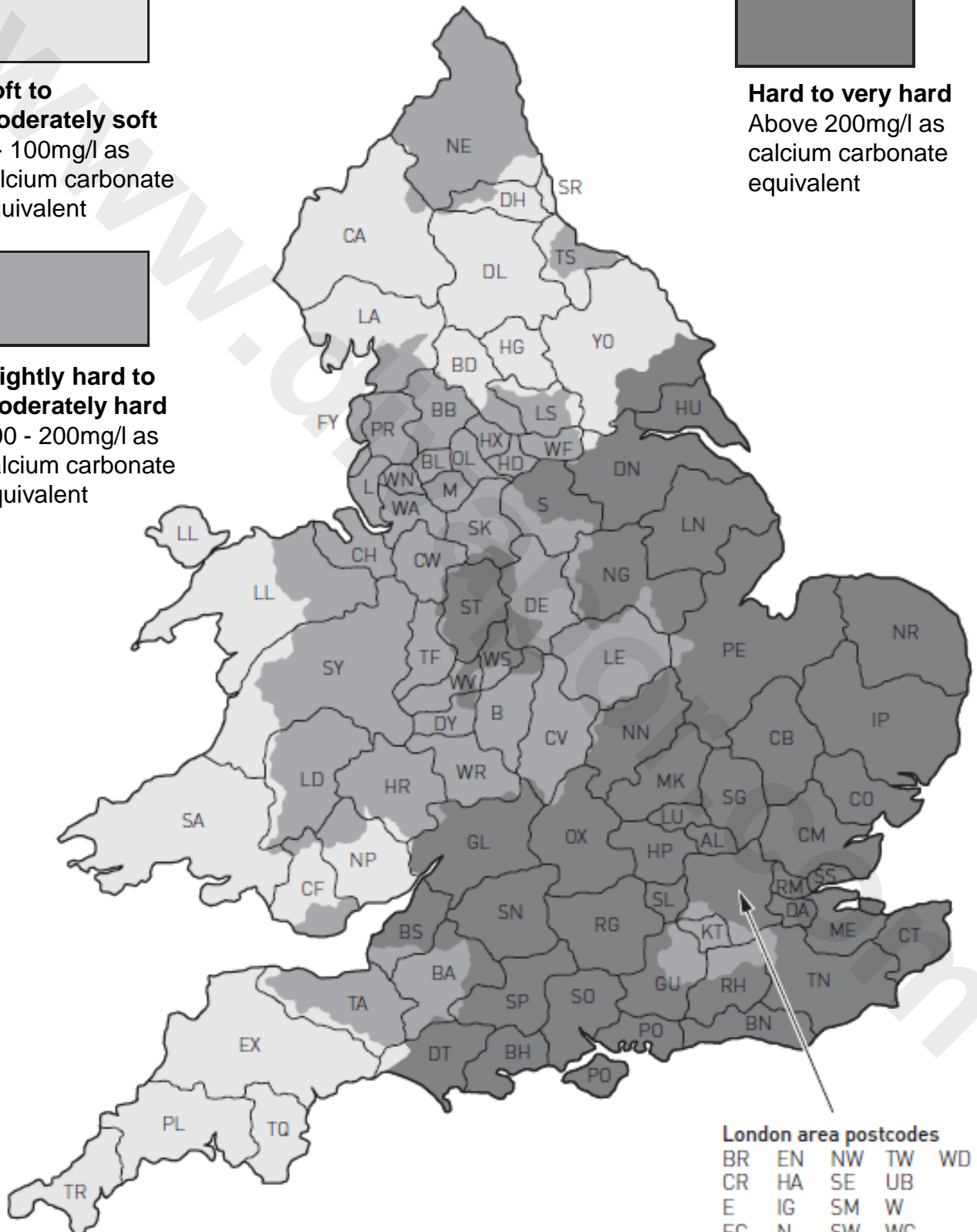

Troubleshooting

Symptom	Cause	Remedy
No flow or poor flow rate.	Partially closed stop or service valve in water supply pipework to the tap.	Open stop or service valve.
	Head of water is below the minimum distance required.	Refer to the Specification section for minimum pressures required.
	Possible airlock / blockage in supply pipework	Remove water supplies from the fitting and flush the system to remove any airlocks / debris.
	Cartridge / Valve not opening fully.	Service fitting. Refer to Cleaning & Maintenance section
Water dripping for a few seconds after the tap has been turned off.	This is caused by 'capillary action' and residual water in the spout being siphoned out. This should only last for a couple of seconds.	
Constant dripping / leaking when the tap is not in use.	Cartridge / Valve not fully shutting off.	Service fitting and replace cartridge / valve. Refer to maintenance section
Fitting does not turn on.	Water supplies not turned on.	Check that the water supplies to the fitting are turned on.
	Closed stop or service valve.	Open stop or service valve.
Water does not come out of the showerhead when using the bath shower mixer.	Diverter mechanism not fully open.	Open the diverter mechanism fully by pulling the diverter knob up.
	Insufficient water pressure / header height.	Refer to the specification section for minimum pressures required.

At Bristan, we want to make things as easy as possible for our customers.

That's why we design products that are easy to fit and use, and that are quality tested to make sure they won't let you down. It's also why we offer solid guarantees on all products, effective from the date of purchase, to give you peace of mind.



Guarantee

All Bristan taps and mixers are covered by a **5 year guarantee**. This also includes **1 year labour cover*** which means that, in the unlikely event that you should encounter a problem in the first year after purchase, we'll send one of our expert engineers to fix it.

*Labour is provided by an approved Bristan Care engineer or appointed representative. The guarantee only applies to products with a manufacturing fault. There will be a call out charge for any incidents where no fault has been found with the product, or if the issue is due to poor installation or maintenance.

Register Now and Extend Your Cover

Register your tap/mixer with us now and we'll extend your labour cover to **2 years – FREE!**

You can register quickly and easily online at www.bristan.com/register. Alternatively, please fill in the details on the enclosed registration card and post it back to us.

Guarantee Terms and Conditions

This guarantee is in addition to your statutory and other legal rights and is subject to the following conditions:

The product was purchased within the United Kingdom or Republic of Ireland.

The product is used in domestic applications only. For commercial or non-domestic applications such as leisure centres, sports clubs, hotels, premises operating as a business, the guarantee period is reduced to 1 year.

The guarantee applies solely to the original purchaser with proof of purchase.

The installation must allow ready access to all products for the purpose of inspection, maintenance or replacement.

Repair under this guarantee does not extend the original expiry date. The guarantee on any replacement parts or product ends at the original expiry date.

Any part found to be defective during the guarantee period will be replaced without charge, providing that the product has been installed in accordance with the instructions given in this guide and used as the manufacturer intended.

The Guarantee Does Not Cover:

- Damage or defects caused by
 - general wear and tear (including special non-chrome finishes; components such as filters, seals, 'O' rings and washers)
 - incorrect installation
 - repair using non-Bristan parts
 - accidental or wilful misuse
 - corrosion and the use of inappropriate cleaning products.
 - system debris including the build up of limescale (which can be controlled through regular servicing and maintenance)
- Compensation for loss of use of the product or consequential loss of any kind.

In the interests of continuous product improvement, Bristan reserves the right to alter product specifications without notice.

The Bristan Product Guarantee does not affect your statutory rights as a consumer.

Need Help?

If your product does not function correctly when you first use it, contact your plumber and make sure that it has been installed and commissioned in line with the instructions in this guide. If this doesn't solve the problem, then please visit www.bristan.com/bristancare for some helpful hints and tips, or contact **Bristan Care Customer Service on 0844 701 6273** where our expert team of advisors will be able to offer you, or your plumber, help and advice.



Guarantee

Problems During the Guarantee Period

In the unlikely event that you encounter any problems with the product during the guarantee period, contact **Bristan Care Customer Service on 0844 701 6273** with your proof of purchase or unique guarantee registration number, and we will work to resolve the problem quickly.

Extended Guarantees

If your product is out of its guarantee period, or you would like to extend the guarantee, then please visit www.bristan.com/customerservice for extended guarantee options.

Bristan Care Customer Support

Bristan customers also benefit from the support of Bristan Care, our comprehensive customer support package which offers:

Technical support hotline (Tel: 0844 701 6273) with access to fully trained advisors who can offer installation advice, talk you through quick maintenance checks, or recommend the best course of action to fix any problems with a product

Expert advice Find easy to follow 'how to' video guides and technical FAQs online at www.bristan.com. Our guides take you step-by-step through many product installations and you can find plenty of easy guides to quick product fixes and servicing.

Spare parts We hold thousands of spares and we keep them for discontinued products for over seven years. Spares can easily be ordered online at www.bristan.com and are dispatched the same day.

Expert plumbing engineers If we can't solve the problem over the phone or with a spare part, then we'll send out one of our Bristan Care engineers to take a look. Bristan Care engineers provide free support for products that are within guarantee, but are also available to service products that are out of guarantee for a small charge. For details, please call customer services on 0844 701 6273.

This booklet covers product codes

CHC HNK C

CHC SNK C

CHC DSM C

Helpline

0844 701 6273

Bristan Group Limited

Birch Coppice Business Park, Dordon, Tamworth, Staffordshire B78 1SG

A Masco Company

Website: www.bristan.com

Telephone: 0844 7016 274 Facsimile: 0844 701 6275

Email: enquire@bristan.com