

1135 / 1422 / 1154 / 8022 / 8030 / 8054

BATH AND BASIN PILLAR TAPS

INSTALLATION GUIDE

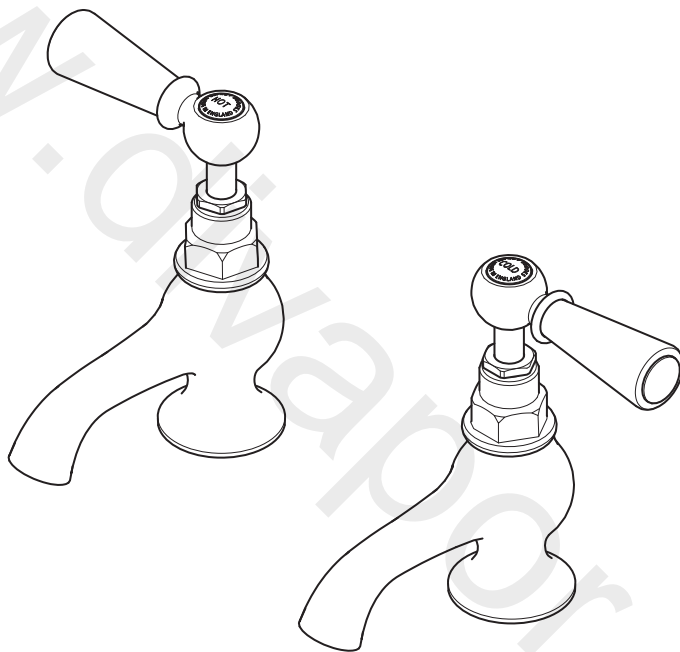

LEFROY BROOKS

IMPORTANT INFORMATION

Professional installation

We recommend that our products are fitted by a fully qualified professional plumber. They should be installed correctly and in accordance with all local water regulations and the system protected by non-return valves (not supplied). All products should be accessible for routine servicing.

Supply temperature safety notice

A thermostatic mixing valve (TMV) should be fitted (not supplied) to the hot supply to restrict the temperature to a safe working/maximum temperature to comply with local building regulations, current legislation, relevant standards and codes of practice. Maximum allowed temperatures vary subject to type of installation or specification of building.

Flushing system

It is most important to flush out all pipework thoroughly before connecting the taps. This is the single most common cause of ceramic cartridge failure.

Supply connections

Lefroy brooks do not supply any pipework or connections for taps as they can be installed in a variety of configurations subject to each customers installation design or requirement.

Water quality

In hard water areas, a suitable water treatment system should be provided to prevent limescale deposits (calcium deposits) which may effect the long term performance of the ceramic cartridge. Exterior surfaces should be gently wiped with a dry soft cloth after use to minimise water stains and limescale deposits.

General installation details

Basin models have ½" BSP threaded tails and are designed to fit standard 15mm tap connectors. Bath models have ¾" BSP threaded tails and are designed to fit 22mm tap connectors. The white sealing washer should be fitted to the underside of the basin/bath/mounting surface, NOT directly under the tap base.

Servicing

All serviceable parts are available to maintain your Lefroy brooks product.

DIMENSIONS

Short nosed taps

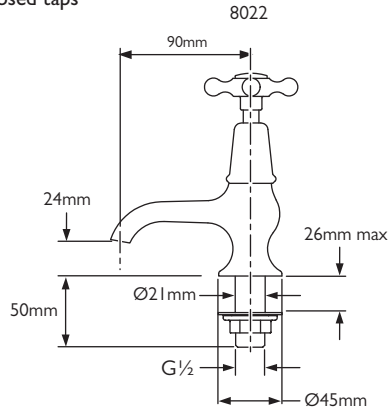
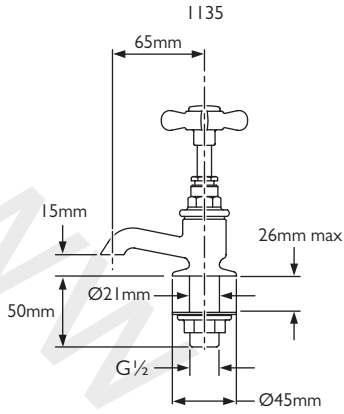

Long nosed taps

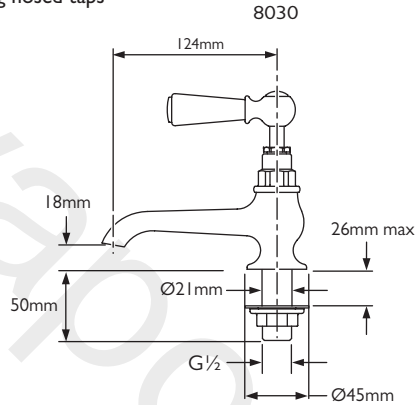
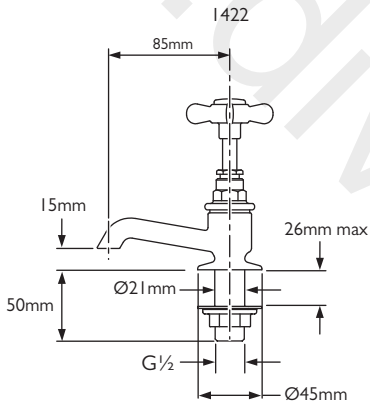

Bath taps

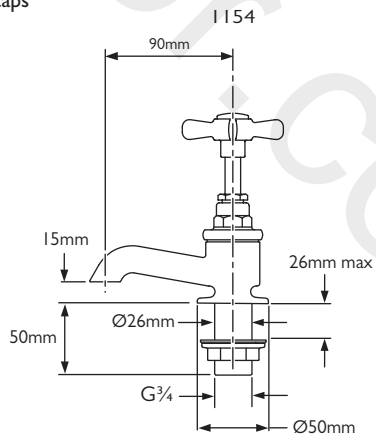
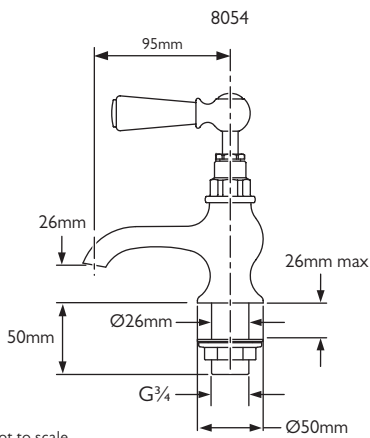

Not to scale

TYPICAL FLOW RATES

Basin taps

(The flow rate indicated is for a single tap.)

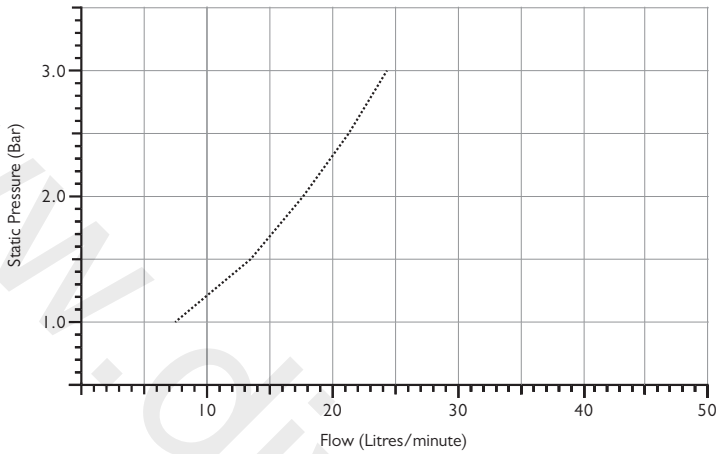

Bath taps

(The flow rate indicated is for a single tap.)

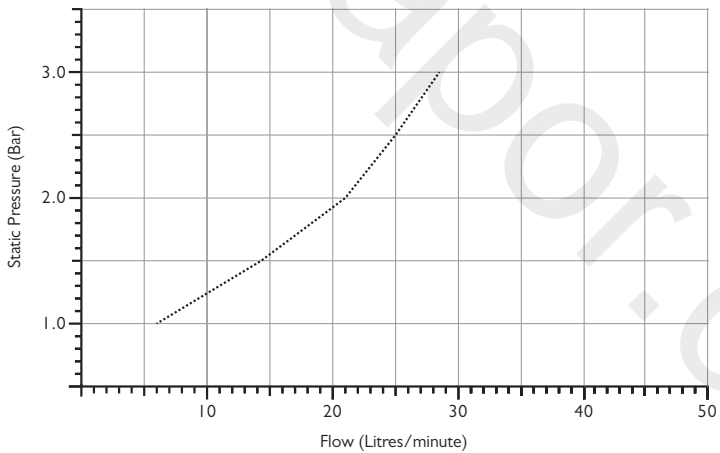

Note: Pressures shown are applied directly to the inlets; flow rates indicated are free flowing and may vary subject to restrictions created by installation, pipework, layout or application.

INSTALLATION

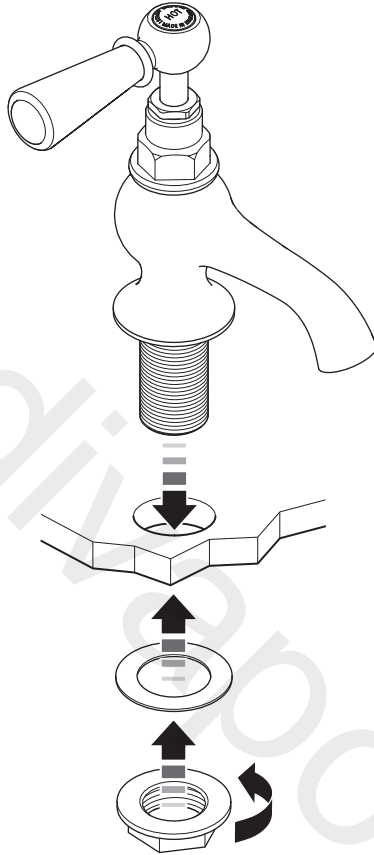

- 1 Remove the backnut and rubber sealing washer from the threaded tail of the tap.
- 2 Locate the threaded tail of the tap through the hole in the mounting surface.
- 3 Place the rubber sealing washer onto the threaded tail of the tap. The raised area in the centre of the rubber washer must be on top.
- 4 Locate and screw the backnut onto the threaded tails.
- 5 Ensure the tap is aligned correctly then tighten the backnut.
- 6 Connect the tap to the water supply.
- 7 Check for leaks and that the tap operates correctly.

SERVICING – CARTRIDGE REPLACEMENT

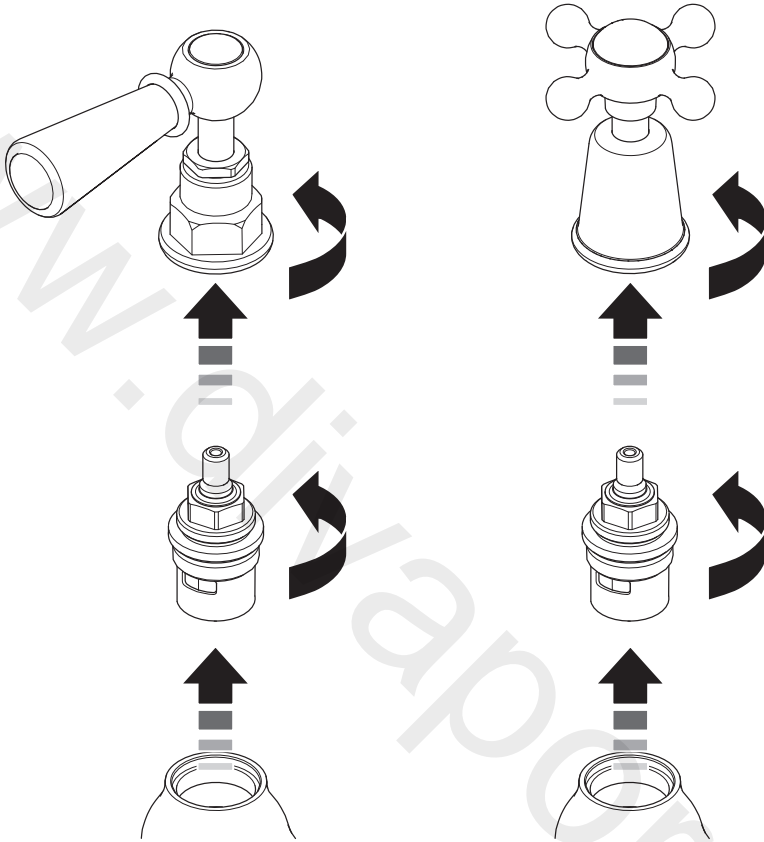

Before continuing please ensure that the water supplies have been isolated and drained where necessary. Always support the spout when removing/fitting handwheel/lever assemblies or ceramic cartridges.

- 1 Unscrew and remove the handwheel/lever assembly in a counterclockwise direction. Wearing rubber gloves such as those used for washing up will improve grip.

- 2 Unscrew and remove the ceramic cartridge in a counterclockwise direction using a 17mm spanner.
- 3 Fit a new ceramic cartridge. Turn the splined end of the ceramic cartridge so that it is in the 'off' position.
- 4 Fit the handwheel/lever assembly ensuring that the indice/graphics are correct.

FAULT FINDING

The tap is turned off but the spout drips continuously.

- Replace the ceramic cartridge. See below for spare part numbers and the 'servicing – cartridge replacement' section

Noisy operation

- Reduce water pressure
-

REPLACEMENT PARTS

Spare cartridges for lever models

PHL035 – Pair of $\frac{1}{2}$ " x $\frac{1}{4}$ turn ceramic cartridges for basin taps

PHL036 – Pair of $\frac{3}{4}$ " x $\frac{1}{4}$ turn ceramic cartridges for bath taps

Spare cartridges for handwheel models

PHL034 – Pair of $\frac{1}{2}$ " x $\frac{1}{2}$ turn ceramic cartridges for basin taps

PHL037 – Pair of $\frac{3}{4}$ " x $\frac{1}{2}$ turn ceramic cartridges for bath taps



CUSTOMER SUPPORT

+44 (0)1992 708 316

LEFROYBROOKS.CO.UK

Whilst every effort is made to ensure the accuracy of these, they are subject to change without notice as part of the company's product development process. The use of trademarks, product design and artwork is subject to licence or agreement with LBIP Ltd. The design registrations, trademark registrations and copyrights are protected by law and the use or reproduction outside the terms of an agreement is prohibited. The right to modify designs and dimensions is reserved. LBIP Ltd is a member of ACID (Anti Copying in Design).