

## customer/technical services

For any technical or installation queries please contact Vado on 01934 745163.

## guarantee

This product is guaranteed against manufacturing defects from the date of purchase until the expiry of the relevant guarantee period shown below.

### The guarantee is only valid if:-

1. The product has been installed, used and maintained in accordance with Vado's instructions and subjected to normal use only.
2. The defect is not due to use of an unsuitable or inadequate water or power supply.
3. The defect is not due to accident, misuse, neglect or repair other than by Vado or Vado authorised agents or damage caused by foreign objects or substances.
4. We have received from you the completed Guarantee Registration Form. Vado accepts no responsibility for any forms lost in the post and returns by registered means is therefore recommended.

Under this guarantee (which is non-transferable) Vado will, at its option, repair or replace free of charge any product (or replacement part) found to be defective. The guarantee does not extend to any consequential loss or damage. After repair or replacement the relevant guarantee period will be calculated from the original date of purchase.

### The relevant guarantee periods are:-

1. Twelve years on chrome finish products.
2. Three years on all other products with the exception of Stuart Turner Pumps which carry a 2 year Guarantee on Monsoon Range and 1 Year Guarantee on Showermate Range.

All claims under the guarantee must be submitted in writing to the person who supplied the product to you and must be received no later than the last day of the relevant guarantee period. All claims must be accompanied by proof of purchase (sales receipt or delivery note).

Vado operates a policy of continuous product development and therefore reserves the right to change the product, packaging and documentation specifications without notice.

This guarantee is in addition to and does not affect your statutory rights as a consumer.

### Vado

Wedmore Road, Cheddar, Somerset, England BS27 3EB  
tel 01934 744466. fax 01934 744345  
technical@vado-uk.com  
www.vado-uk.com

### GUARANTEE REGISTRATION

NAME				
ADDRESS				
	POSTCODE			
RETAILER				
ADDRESS				
	POSTCODE			
PURCHASE DATE	ARTICLE NUMBER	(SEE BOX)		
PRODUCT DESCRIPTION				
WHO INSTALLED THE PRODUCT?	RETAILER	PLUMBER	BUILDER	SELF
FOR VADO USE				

VADO

## installation & maintenance instructions

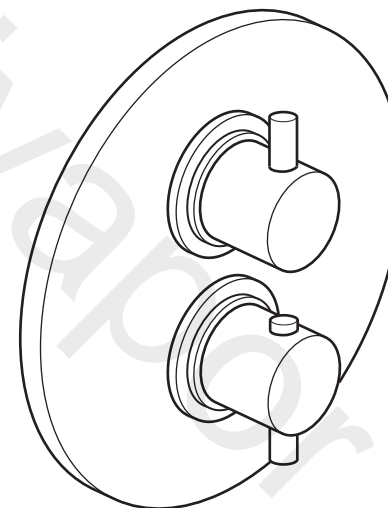

# celsius

concealed thermostatic shower valve  
with round backplate  $\frac{3}{4}$ "

Version 1

**please leave these instructions with the customer**

## important - please read

Please read these instructions carefully before starting installation and keep for future reference.

Remove all packaging and check the product for missing parts or damage before starting installation.

Any alterations made to this product and fittings may infringe water regulations and will invalidate the guarantee.

The installation must comply with all Local/National Water Supply Authority Regulations/Byelaws and Building and Plumbing (UK:BS6700) Regulations.

We strongly recommend that you use a qualified and registered plumber.

## general installation

### Thermostatic Valves

This mixer valve is suitable for any water system. Where instantaneous heaters are used, the flow of hot water sufficient to start and go on burning must reach the minimum flow required – as specified by the heater manufacturer.

These fittings are mixing devices and therefore water supplies must be reasonably balanced.

Where connections are made to the mains cold water supply, WRC approved single check valves must be fitted to both hot and cold inlets. This is a stated requirement of Water Supply (Water Fittings) Regulations 1999 Schedule 2, Section 6 G15.13.2

Before making any inlet pipe connections, all supply pipes MUST be thoroughly flushed to remove debris. Failure to do so could result in damage or low flow from the mixer unit. Water Supply (Water Fittings) Regulations 1999 Schedule 2 Section 4 G13.1

The fitting of isolating valves to the inlet feeds is advised for ease of maintenance.

Please take great care when installing this mixer not to damage its surface.

Operating pressures (on hot and cold line) should be kept as balanced as possible in order to assure optimum efficiency.

Note: When pressure is higher than 5 bar a pressure reducer is required to be fitted before the valve.

Please note if installing in an enclosed environment, access should be left for servicing and maintenance. No costs relating to inadequate access can be accepted.

## care of the mixer

Our products are finished to the highest standard and due care needs to be taken to ensure their looks are retained.

We recommend cleaning all products with a soft damp cloth ONLY and advise strongly against the use of ALL cleaning products i.e. powders and liquids.

If the above instructions are not followed this will invalidate your guarantee in the event of a problem occurring.

## maintenance

We advise that the below is carried out annually as failure to do so may result in invalidation of warranty.

This thermostatic valve is fitted with a double filtering facility. Filters are fitted on the water inlets and on the thermostatic cartridge.

Depending on the water quality, filters may become dirty, causing reduced flow and inefficient working of the valve.

Shut off the water supply to both inlets at the isolating valves.

### Inlet Filters.

Undo both inlet filters each side of the cartridge using a 27mm box spanner. Pull out the filter/non return valve, rinse in water to remove the dirt, and then soak them in vinegar or descaling agent. Grease the 'O' rings and replace.

### Cartridge Filters

To clean the filters, you must first remove the cartridge from the housing.

Removing the Cartridge

1. Shut off the water supply to both inlets at the isolating valves.
2. Remove the handle, cover plate ring, cover plate inner ring, temperature valve ring to gain access to the grub screw.
3. Release the grub screw on the underside, and remove the thermostatic cartridge by unscrewing.
4. Clean the filters by rinsing them in water to remove the dirt and soaking them in vinegar or descaling agent.
5. Before reassembling the cartridge, clean its housing with a wet cloth and grease the 'O' rings on the cartridge. Reassemble the cartridge.
6. Screw the cartridge back into the valve and secure with the grub screw on the underside.
7. Place the black plastic stop ring so that the stop is at the 12 o'clock position.
8. Make sure everything is tight and secure, turn on the water supply at the isolating valves.
9. Now check the water temperature to ensure you are happy with it.
10. Replace the 3 rings and the handle.
11. Secure the handle.

## dimensions

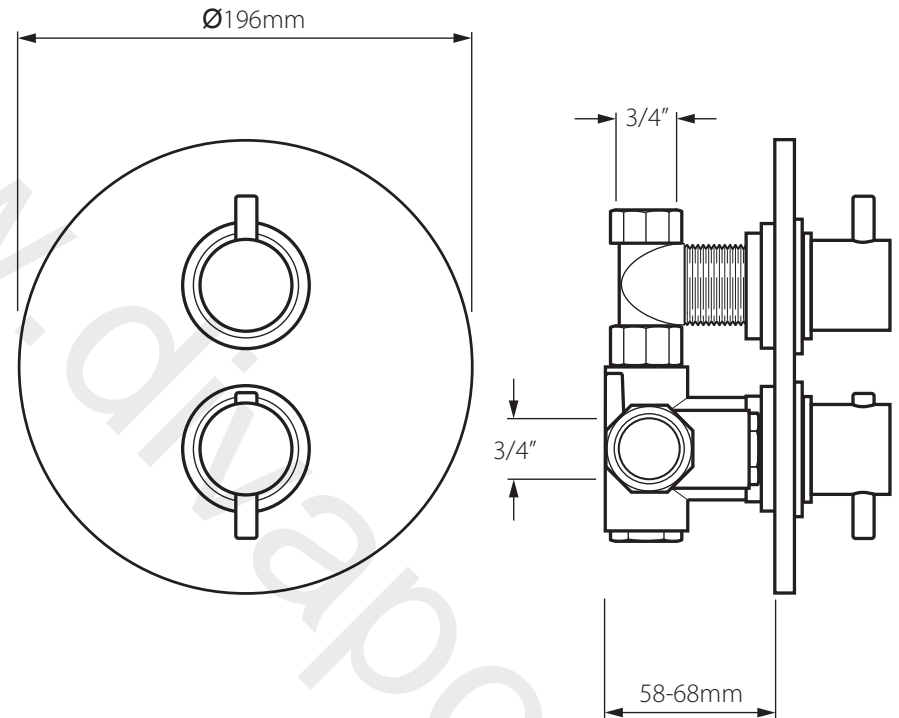

**Please Note:** If using optional extension shrouds the MIN - MAX depth dimensions become: 68mm - 96mm.

## Operating Specifications

Hot Water Supply Temperature:

Maximum: 80° C

Minimum: 10° C higher than the maximum required mixed temperature (advise 65° C)

Operating Pressure

Maximum: 5 bar

Minimum: 0.2 bar

## installation - standard fixing

Rinse pipeworks carefully for a long while before fitting the valve: do not allow dirt, metal particles or shavings to block the filters fitted on inlets.

**⚠ Warning!** Please check for any hidden cables and pipes before drilling holes in the wall.

**Please note:** That access must be left to the thermostatic cartridge grub screw in order to release the cartridge for maintenance at a later stage.

The valve must be set into the wall between (58mm minimum – 68mm maximum) If you are fitting the valve to a partition wall or a wall of particularly soft substrate you will need specialist fixings. Select the position for the shower valve and offer the shower valve to the wall, mark the 2 fixing points with a suitable pencil. Remove the shower valve from the wall, drill the holes to a suitable depth for the wall plugs and secure with suitable screws.

During and after installation protect the outer parts by leaving the clear plastic protective carton on the valve to avoid damage to plated surfaces.

Connect hot supply to left inlet of the valve and cold supply to right inlet. Adaptor supplied to aid fitting of valve where pipe sizes  $\frac{1}{2}$ " or  $\frac{3}{4}$ " may be used.

Make all outlet connections to the valve.

If blanking plug at base of valve is removed for additional outlets, please ensure a separate volume control is installed i.e. stop valve, between valve and delivery point.

Screw the flow valve ring onto the top valve, and the temperature valve ring onto the bottom, screw on both cover plate inner rings.

Slide the cover plate over the valve and secure to the wall with both cover plate rings.

### Flow control handle (top)

Carefully slide the flow control handle onto the splines of the top valve, with the lever at 12 o'clock, secure the handle with the grub screw on the underside.

### Temperature control handle (bottom)

Push on the stop ring with the stop at the 12 o'clock. Remove the lever from the temperature control handle by unscrewing (grub screw underneath), slide onto the splines with the override button at 12 o'clock, secure with the grub screw and replace the lever.

## temperature resetting

The valve has been factory set under balance pressures and hot water supply at 65° C. When your specific operating conditions are significantly different from the above, the temperature of the water may vary from the setting.

When the difference is too great, you can adjust the calibration of the valve to suit individual requirements of the installation:

1. Select 38° C or the arrow on the handle and check the temperature of the water being delivered to the outlet with a thermometer.

2. If the temperature is unacceptable proceed to reset the calibration as follows:

Remove the handle (do not remove the plastic stop ring). Turn the spline of the valve clockwise to decrease the temperature and anti-clockwise to increase the temperature until 38° is achieved.

3. Ensure that the stop on the stop ring is at 12 o'clock and replace the handle with the temperature override button also pointing at 12 o'clock being careful not to turn the spline of the valve, replace the handle (see above).

The valve setting is now calibrated to suit your requirements.

## operation

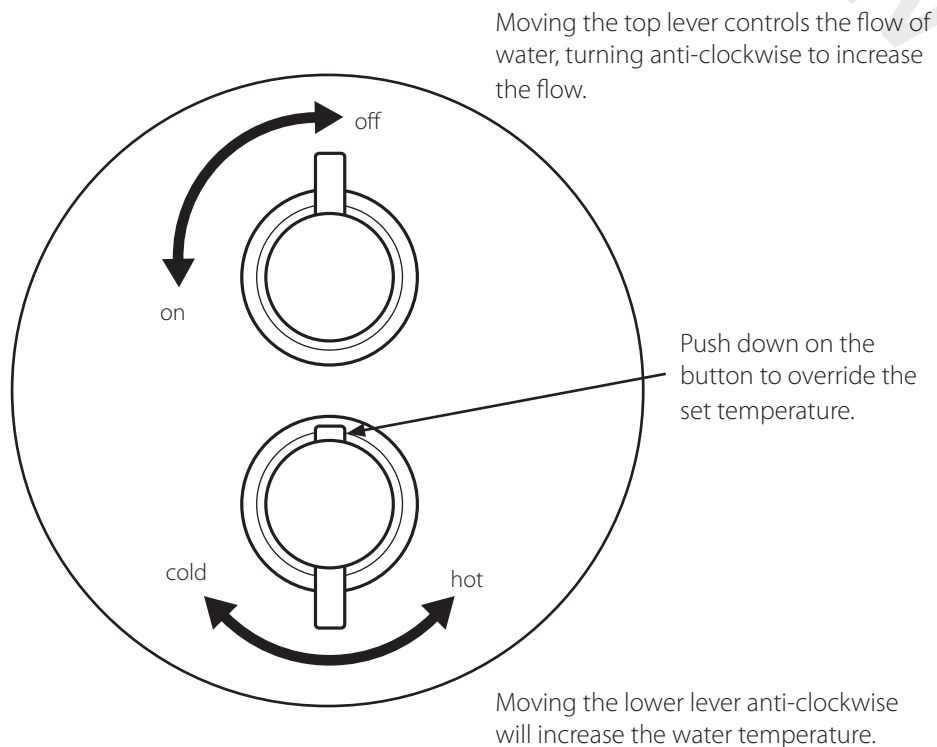

## installation - standard fixing

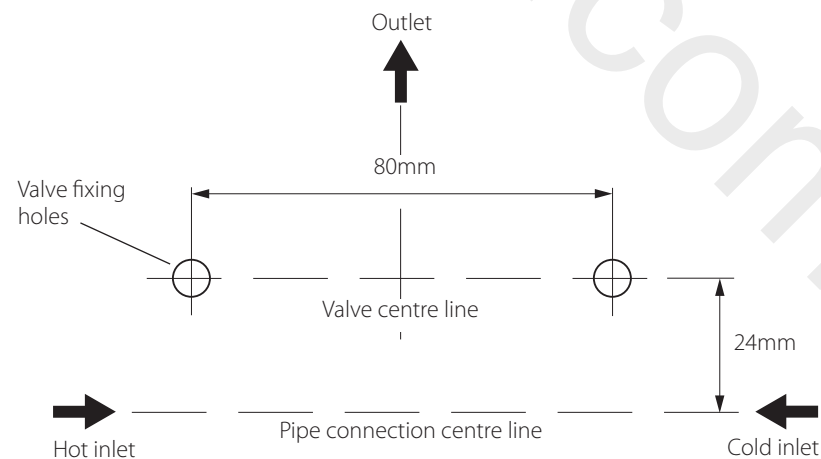
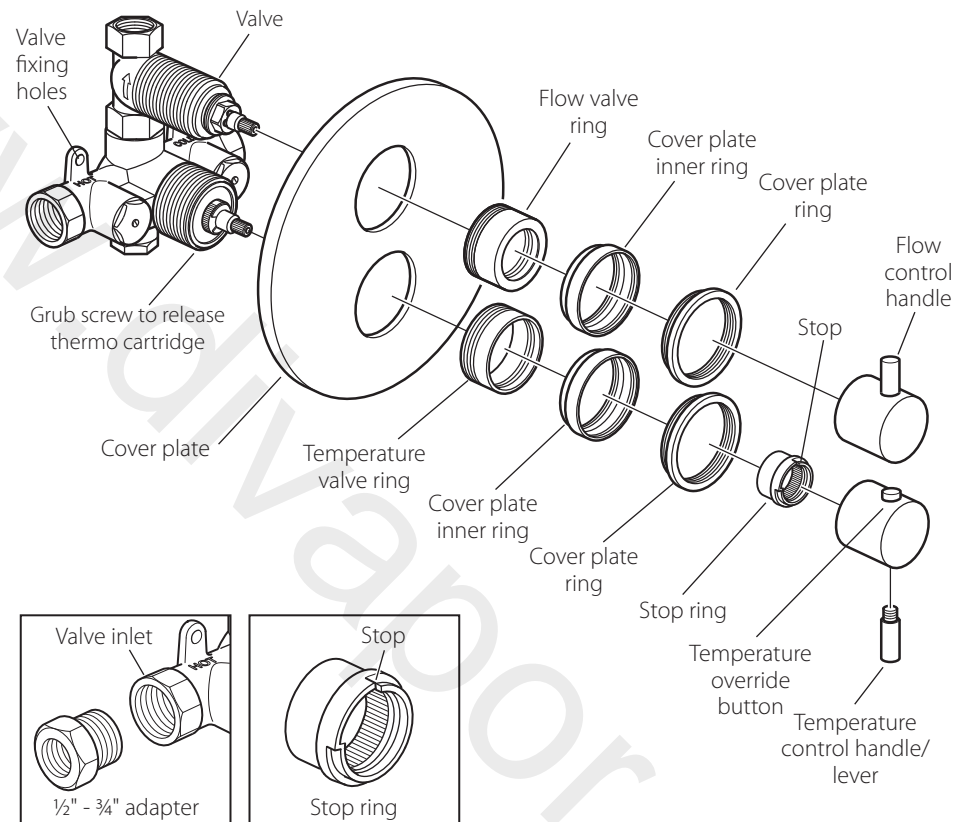

## installation - extended fixing (optional)

Rinse pipeworks carefully for a long while before fitting the valve: do not allow dirt, metal particles or shavings to block the filters fitted on inlets.

**Warning!** Please check for any hidden cables and pipes before drilling holes in the wall.

**Please note:** That access must be left to the thermostatic cartridge grub screw in order to release the cartridge for maintenance at a later stage.

The valve must be set into the wall between (68mm minimum – 96mm maximum)  
If you are fitting the valve to a partition wall or a wall of particularly soft substrate you will need specialist fixings. Select the position for the shower valve and offer the shower valve to the wall, mark the 2 fixing points with a suitable pencil. Remove the shower valve from the wall, drill the holes to a suitable depth for the wall plugs and secure with suitable screws.

During and after installation protect the outer parts by leaving the clear plastic protective carton on the valve to avoid damage to plated surfaces.

Connect hot supply to left inlet of the valve and cold supply to right inlet.  
Adaptor supplied to aid fitting of valve where pipe sizes  $\frac{1}{2}$ " or  $\frac{3}{4}$ " may be used.

Make all outlet connections to the valve.

If blanking plug at base of valve is removed for additional outlets, please ensure a separate volume control is installed i.e. stop valve, between valve and delivery point.

Screw the flow valve ring onto the top valve, and the temperature valve ring onto the bottom, screw on both cover plate inner rings.

Slide the cover plate over the valve and secure to the wall with both cover plate rings.

### Flow control handle (top)

Slide the spline adapter onto the splines on the valve and secure in position with the screw. Carefully slide the flow control handle onto the splines of the adapter, with the lever at 12 o'clock, secure the handle with the grub screw on the underside.

### Temperature control handle (bottom)

Slide the spline adapter onto the splines on the valve and secure in position with the screw. Push on the stop ring with the stop at the 12 o'clock.

Remove the lever from the temperature control handle by unscrewing (grub screw underneath), slide onto the splines of the adapter with the override button at 12 o'clock, secure with the grub screw and replace the lever.

## installation - extended fixing (optional)

