

**ISTRUZIONI DI MONTAGGIO**

**IT**

**FITTING INSTRUCTIONS**

**EN**

**INSTRUCTIONS DE MONTAGE**

**FR**

**INSTRUCCIONES DE MONTAJE**

**ES**

**INSTRUÇÕES DE MONTAGEM**

**PO**

**batlò**



**BI250**



**BI350**

**Fig. 1/2**

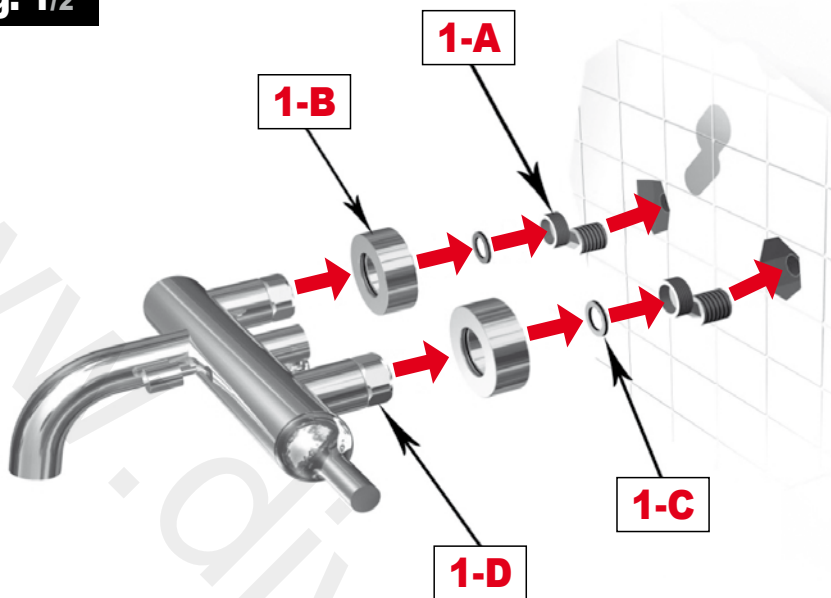

**IT**

Avvitare i dadi eccentrici (**1-A**) agli attacchi a muro che devono avere un interasse di 150 mm (5.91in), o comunque compresi tra un minimo di 130 mm (5.12in) e un massimo di 170 mm (6.69in). Inserire i rosoni scorrevoli (**1-B**) sul corpo miscelatore (**1-D**). Collegare il corpo miscelatore ai dadi eccentrici inserendo le guarnizioni (**1-C**).

**EN**

Screw the eccentric nuts (**1-A**) to the wall connections, which must have a distance of 150 mm (5.91 in) between centers or, in any case, a minimum of 130 mm (5.12 in) and a maximum of 170 mm (6.69 in). Insert the smooth roses (**1-B**) on the mixer body (**1-D**). Connect the mixer body to the eccentric nuts, inserting the gaskets (**1-C**).

**FR**

Visser les écrous excentriques (**1-A**) aux fixations murales dont l'entraxe doit être de 150 mm (5.91in), ou compris entre un minimum de 130 mm (5.12in) et un maximum de 170 mm (6.69in). Insérer les brides coulissantes (**1-B**) sur le corps mitigeur (**1-D**). Relier le corps mitigeur aux écrous excentriques en insérant les garnitures (**1-C**).

**ES**

Enroscar las tuercas excéntricas (**1-A**) a los enganches de la pared que deben tener una distancia entre ellos de 150 mm (5.91 pulgadas), o estar comprendidos entre un mínimo de 130 mm (5.12 pulgadas) y un máximo de 170 mm (6.69 pulgadas). Introducir los embellecedores correderos (**1-B**) en el cuerpo del mezclador (**1-D**). Conectar el cuerpo del mezclador a las tuercas excéntricas introduciendo las juntas (**1-C**).

**PO**

Aparafuse as porcas excêntricas (**1-A**) aos suportes de parede, os quais têm que ter um entre-eixo de 150 mm (5.91in), ou pelo menos têm que se encontrar entre um mínimo de 130 mm (5.12in) e um máximo de 170 mm (6.69in). Insira os aneis corredios (**1-B**) no misturador (**1-D**). Ligue o misturador às porcas excêntricas inserindo as vedações (**1-C**).

**Fig. 2/2**

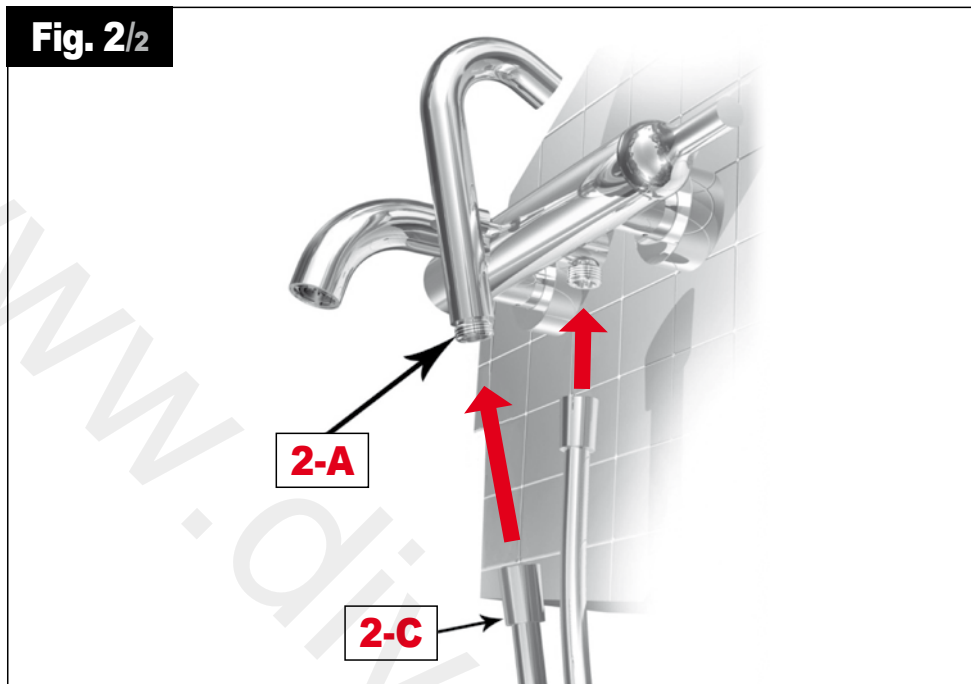

**IT**

Collegare il flessibile **(2-C)** al corpo miscelatore **(1-D)** e al doccino **(2-A)**. Inserendo le guarnizioni di tenuta.

**EN**

Connect the flexible hose **(2-C)** to the mixer body **(1-D)** and the spray handle **(2-A)**, inserting the gasket seal.

**FR**

Relier le flexible **(2-C)** au corps mitigeur **(1-D)** et à la douchette **(2-A)**. En insérant les garnitures étanches.

**ES**

Conectar el tubo flexible **(2-C)** al cuerpo del mezclador **(1-D)** y a la ducha **(2-A)**. Introduciendo las juntas de retén.

**PO**

Ligue o tubo **(2-C)** ao misturador **(1-D)** e ao chuveiro **(2-A)** inserindo as vedações à prova de fuga.

www.divapor.com

### **IMPORTANT**

#### **Pressure & Temperature Requirements.**

- \* Hot and cold water inlet pressures should be equal.
- \* Inlet pressure range: 150-1000 kPa
- \* New Regulation: -500 kPa maximum operating pressure at any outlet within a building. (Ref. AS/NZS 3500.1-2003, Clause 3.3.4)
- \* Maximum hot water temperature: 80°C.



[www.ibrubinetterie.it](http://www.ibrubinetterie.it)

#### **IB RUBINETTERIE s.p.a.**

via dei Pianotti 3/5  
25068 Sarezzo (BS)  
phone +39 030 802101  
fax +39 030 803097  
[ibrubinetterie@ibrubinetterie.it](mailto:ibrubinetterie@ibrubinetterie.it)  
[www.ibrubinetterie.it](http://www.ibrubinetterie.it)