

INSTALLATION INSTRUCTIONS

Grand Wall Valve - 20007013230

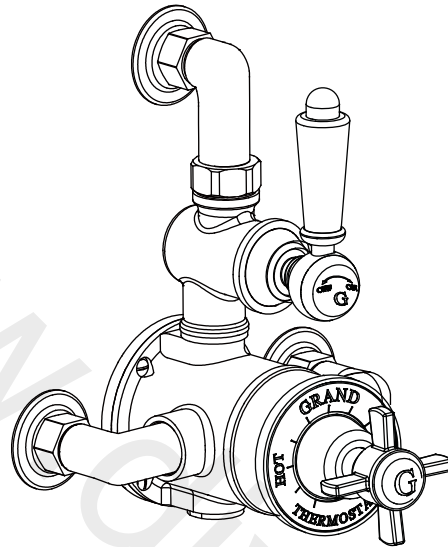

Important

- We recommend that this product is installed by a qualified professional plumber who is certified by NVQ (National Vocational Qualification) or SNVQ (Scottish National Vocational Qualification) Level 3.
- Please check this product upon delivery to ensure that it has not been damaged and is complete.
- Before installation, please make sure this product is the correct model and you have all the parts required for installation and use.
- If possible the valve should be supplied with hot and cold water at balanced pressure.
- It is important to flush the water system to ensure that no swarf, solder, or any other impurity or foreign body can enter the valve.
- Turn off the water supply before commencing work, this should be done at the isolating valves or inlet feeds if fitted, or otherwise at the main stopcock.
- Please read these instructions carefully and keep them for future reference.

Conditions for the use of thermostatic mixing valve

The thermostatic valve has been designed to be compliant with the relevant UK standards applicable to this type of product governed by TMV2 standards and WRAS. The valve is tested against BS EN 287 & BS EN 1111.

The valve will operate under low pressure but it is recommended that the cold water supply is at least 2 meters above the outlet of the shower valve.

- This thermostatic valve is suitable for use with all water systems up to a maximum operating pressure of 5.0 bar, (beyond which we recommend pressure reducing valves to be fitted.)
- The valve is provided with one outlet (on the top), which is controlled by a flow control cartridge. Commonly used for a main shower head or a flexible shower kit.
- If installing a shower pump always install the pump before the shower valve.

The list below shows the recommended limits for correct operation;

	Recommended Conditions
Maximum Static Pressure – Bar	10
Flow Pressure, Hot & Cold - Bar	0.2 to 5
Hot Supply Temperature - °C	55 to 65
Cold Supply Temperature - °C	Equal to or less than 25°

The British Burns Association recommends 37 to 37.5°C as a comfortable bathing temperature for children. In premises covered by the Care Standards Act 2000, the maximum mixed water outlet temperature is 43°C.

Dimension

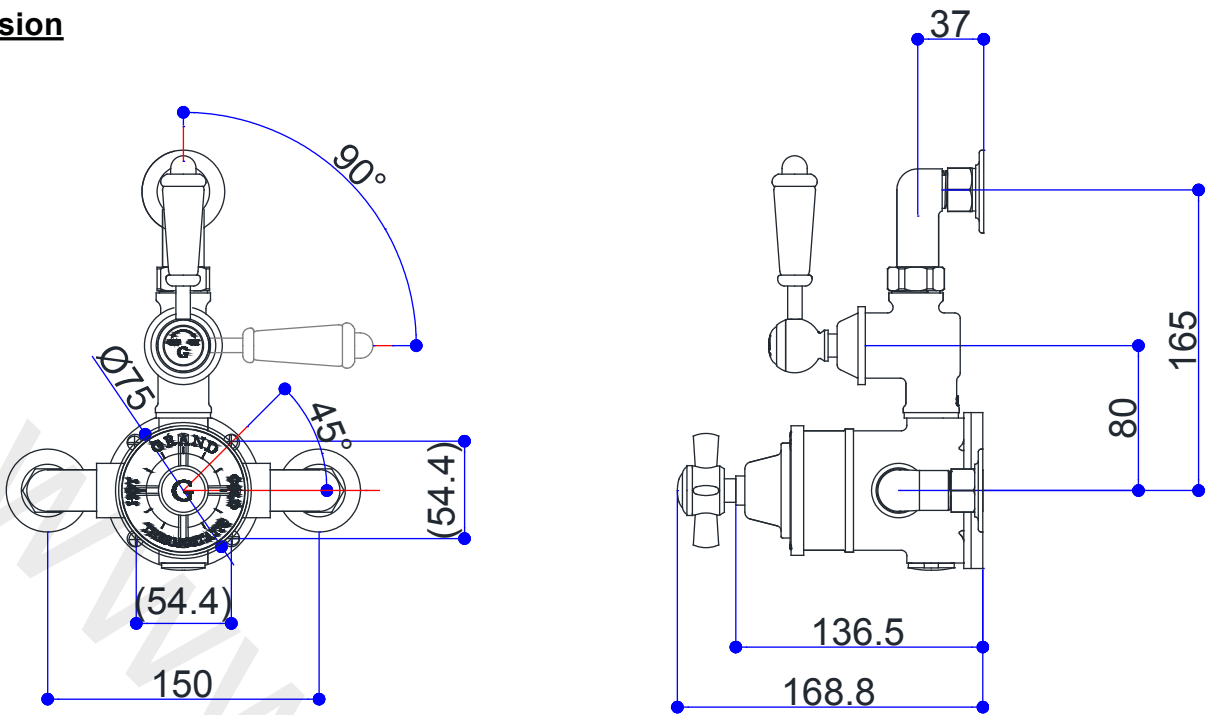

Parts Identification

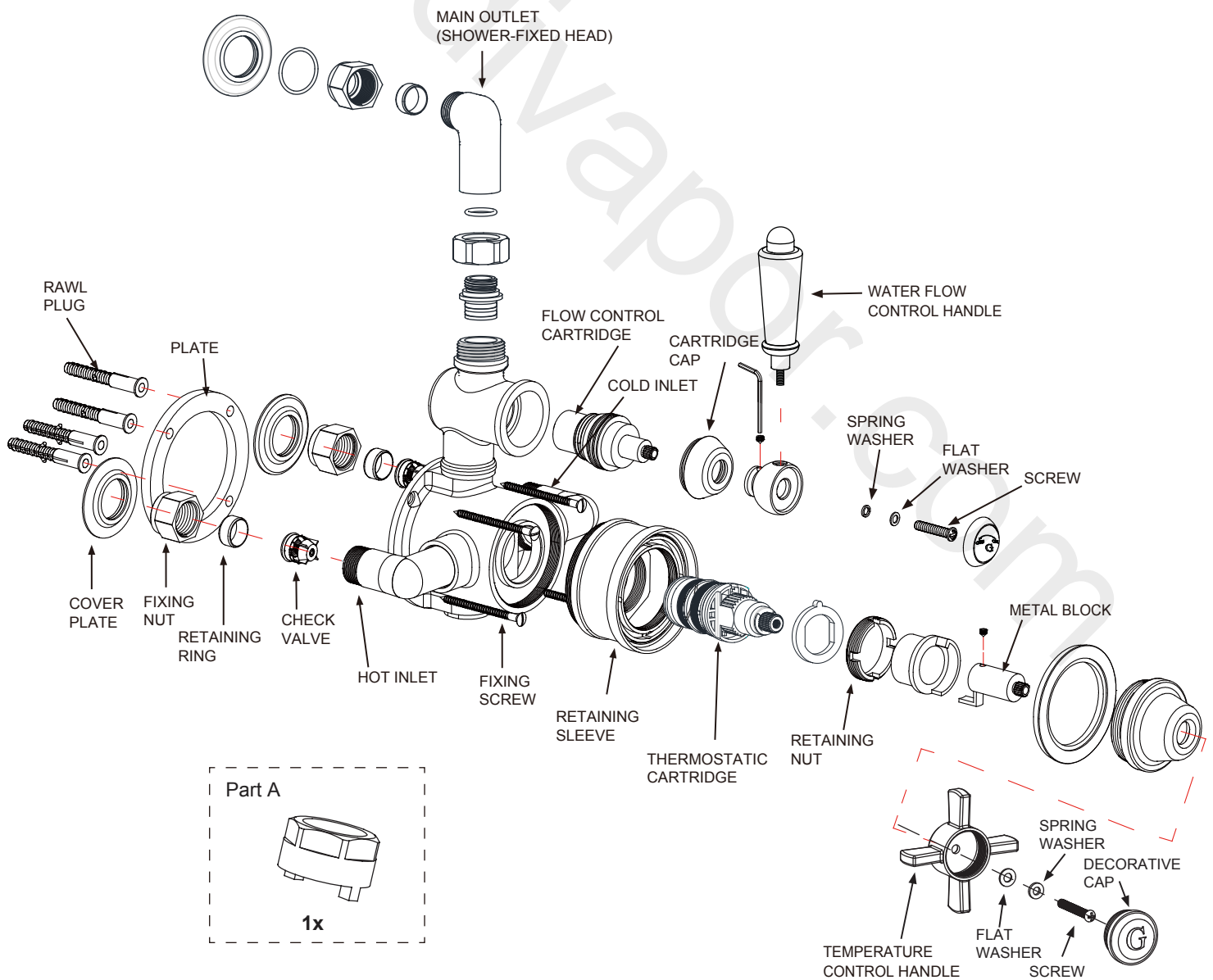

Installation

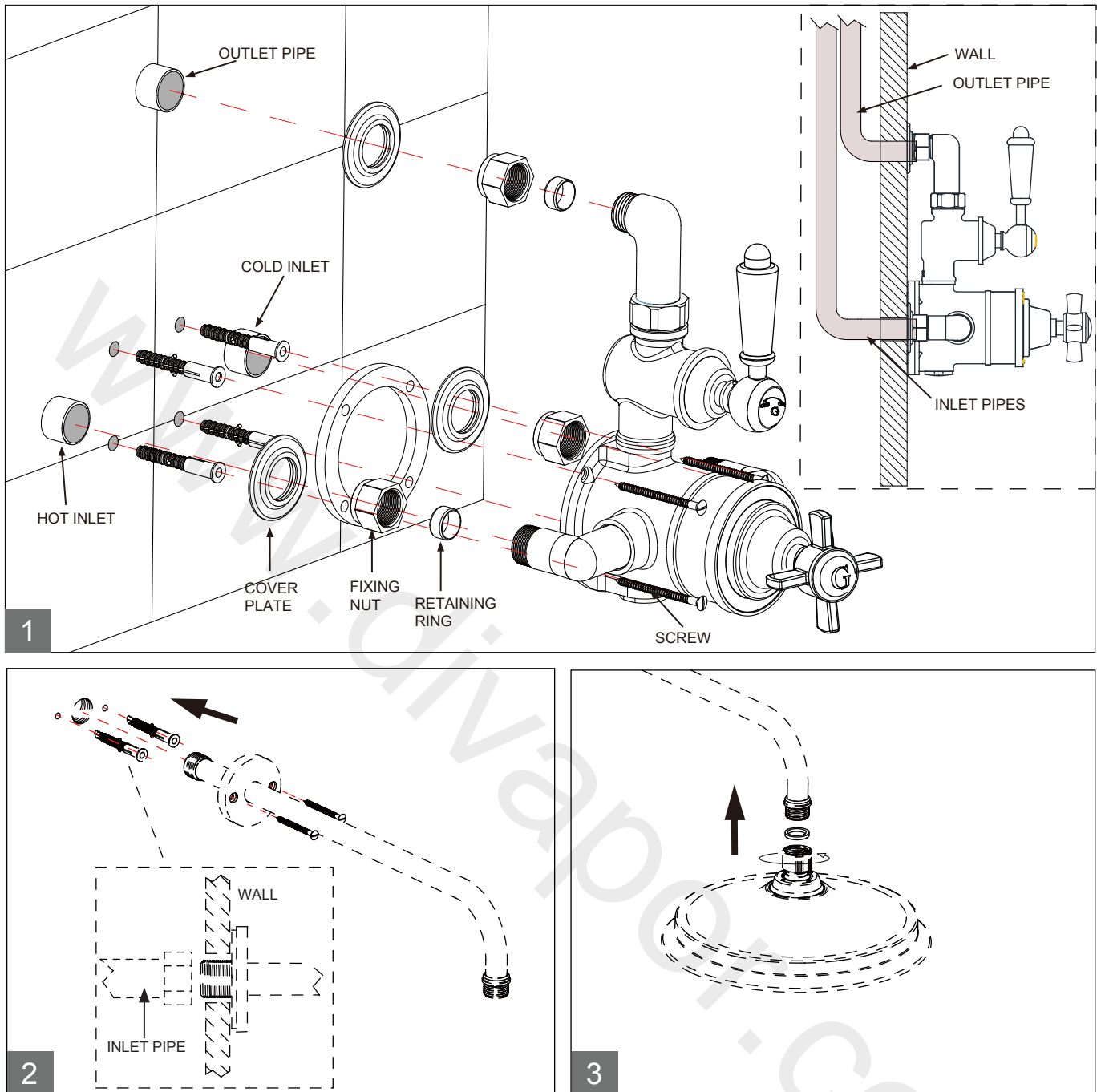

The valve should be installed in accordance with the water bye-laws. For further details refer to the latest copy of Water Bye-laws guide or your local water authority.

Note: Please check for any hidden pipes and cables before drilling holes in the wall.

The fitting of isolation valves is required as close as is practicable to both hot and cold water supply inlets.

1. a: Determine the final installation position and installation height.
- b: Prepare the water supply pipes (hot on the left and cold on the right) at the identified height with a width of 150mm centers. Make the ends of pipes 20-25mm out from the face of wall.
- c: Make an outlet at 165mm distance above the center of two inlets.
- d: Put the shower valve against the wall, mark the position of the 4 fixing holes following the plate.
- e: Drill 4X8mm holes on the wall to a depth of 45mm and insert wall plugs.
- f: Push the shower valve over each pipe. Slide the cover plates against the wall, join inlet elbows to hot/cold pipe from the wall. For the outlet, follow the same method as the inlet pipes.
- g: Finally mount the shower valve onto the wall by using the 4 screws.
2. Install the shower arm (see Fig 2).
3. Finally put the shower head onto the shower arm (see Fig 3).

Operation

1. Turn the water flow control handle to increase/decrease the water flow and turn on/off.
2. Turn the temperature control handle to increase/decrease the water temperature.
3. The temperature control knob is pre-set the auto stop at 42°C to avoid scalding.

However, if for any reason the setting is removed it is important to follow "Temperature Setting" procedure to reset.

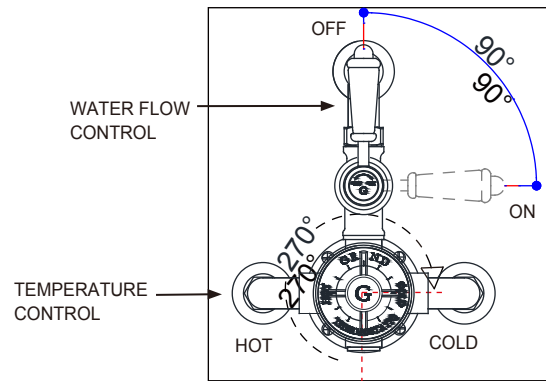

Temperature Setting

The temperature control handles on this product are factory set and should require no adjustment.

However, if for any reason the handles and/or the cartridge is removed it is important the following procedure is followed.

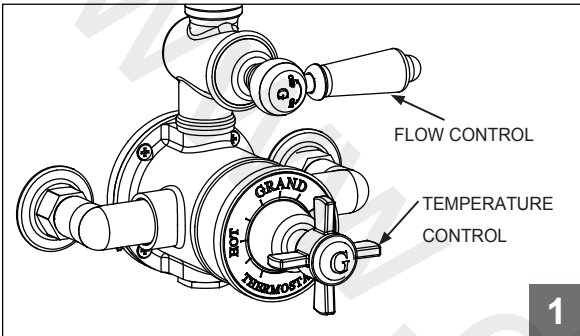

- Turn flow control handle to maximum flow position, and temperature control handle anti-clockwise until it contacts the internal limit stop.
- Allow the water temperature to stabilize for around 3 minutes and check the temperature by thermometer.
- Proceed if temperature is not 42°C.

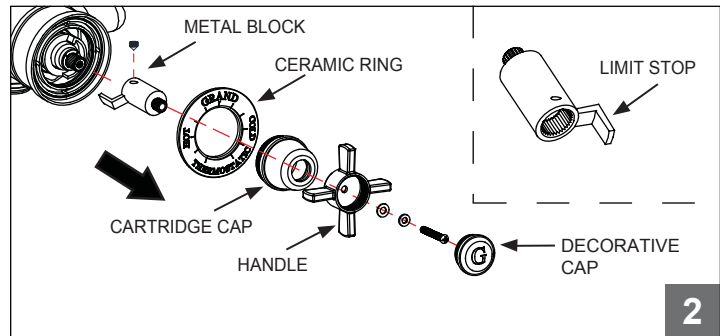

- Turn off the water
- Unscrew the decorative cap on the temperature control handle.
- Unscrew and remove the handle.
- Unscrew and remove the cartridge cap.
- Pull off the metal block with limit stop on the backside.

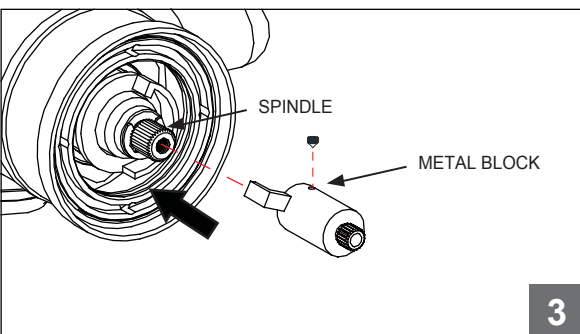

- Temporarily refit the metal block until it just engages on the splines of the spindle.
- Turn on the water.
- Slowly turn the metal block in the required direction until the discharge temperature is achieved.
- Remove the metal block when finished.

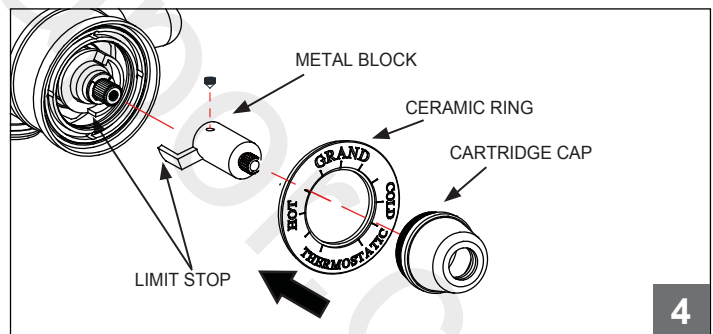

- Without rotating the temperature spindle, replace the metal block so that the limit stop inside the metal block is up against the right hand side of the limit stop on the plastic block.
- Refit and tighten the cartridge cap and screw. Refit and tighten the decorative cap.

Maintenance(Thermostatic Cartridge & flow control Cartridge)

* After a long time usage of thermostatic valve, there will be some waste debris from the water pipe on and around the thermostatic cartridge, which will affect the flow and sensitivity of automatical temperature adjustment. Please take out the thermostatic cartridge, and clean the cartridge strainer

* To avoid damage, please remove all chrome parts before any maintenance takes place.

- Turn off the water supply to the valve before removing any components.
- Remove the cartridge cap, ceramic ring and metal block (see Fig. 1)
- Remove the metal ring, plastic block and cartridge clamp nut (see Fig. 2).
- Pull out the cartridge together with location lug (see Fig. 3).
- Wash the cartridge with clean running water, dry and lightly grease the seals (only use silicone grease) (See Fig. 4).
- Replace the cartridge and make sure it back to the primary position.
- Maintenance for the flow control cartridge is in the same way.

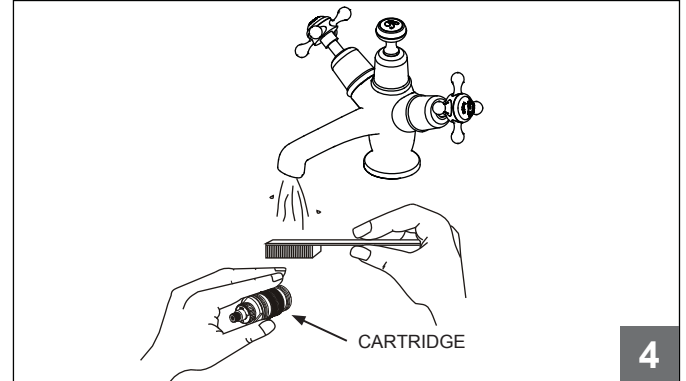
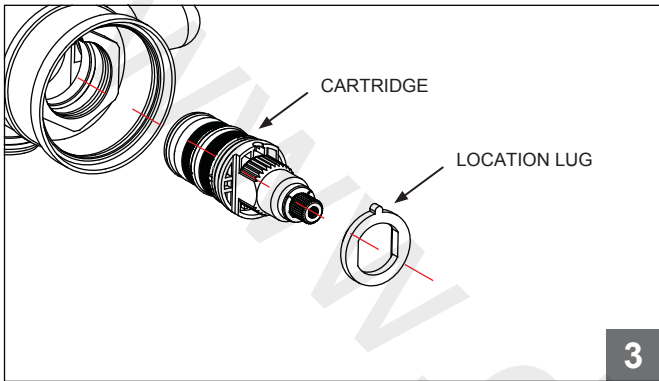
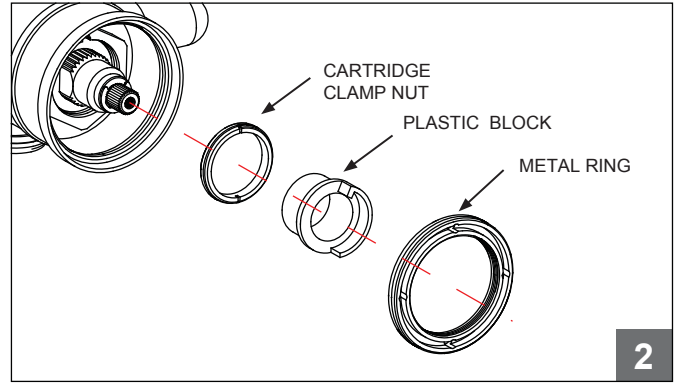
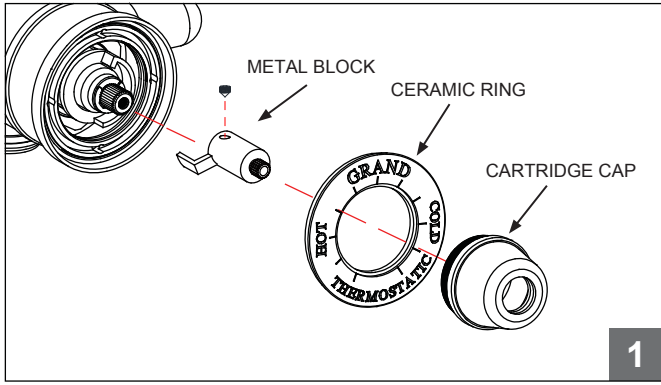

Trouble Shooting

1. Output water temperature does not correspond with temperature set

Cause: Thermostat has not been adjusted to the existing home water system

Remedy: Adjust the thermostat, refer to "Temperature Setting" procedure.

Cause: Hot Water temperature too low.

Remedy: Adjuster the water heater, increase hot water temperature to 65°C

2. Crossflow, cold water being forced into hot water pipe, or vice versa, when valve is closed

Cause: Non-return valves dirty or leaking

Remedy: Clean the non-return valves or remove if necessary

3. Very low flow or no flow

Cause: Supply pressure inadequate

Remedy: Check hot and cold feeds. If a pump has been installed, please check to see if the pump is working.
(the valve will shut down if either the cold or hot water supply fails)

4. Water will not run hot enough when first installed

Cause: Wrong maximum temperature setting

Remedy: Adjust the maximum temperature, refer to "Temperature Setting" procedure.

Cleaning

We do NOT recommend you use any household cleaners to clean the product. The product should only be cleaned with soapy water, rinsing with clean water, and dried with soft cloth.

INSTALLATION INSTRUCTIONS

Grand Shower Head - 20007013240

Important

- Please check this product immediately to ensure that it has not been damaged and is complete. Before installation, please make sure this product is the correct model and you have all the parts required for installation and using.
- Please read these instructions carefully and keep it for future reference.

Installation

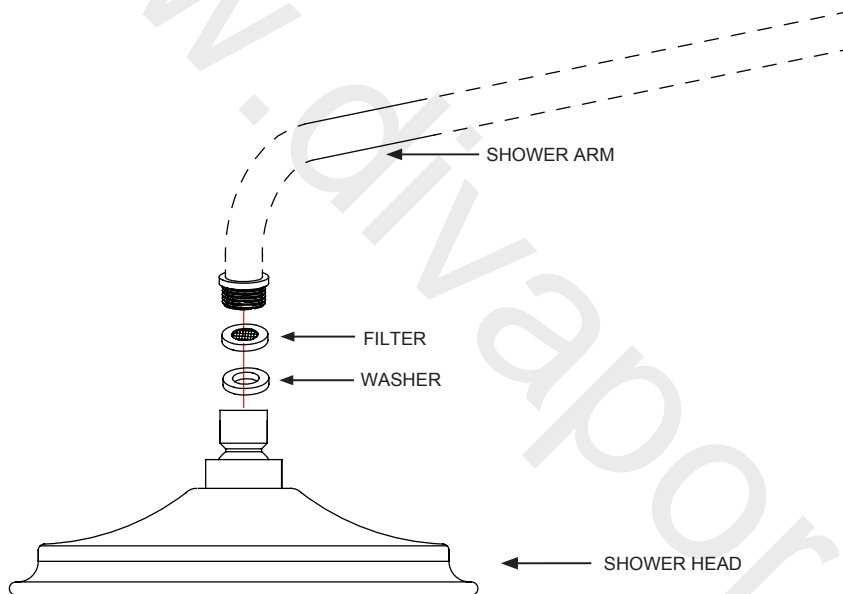

Dimension

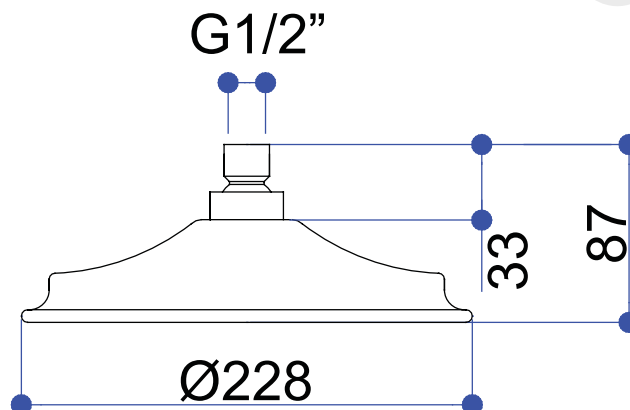

Maintenance

We do NOT recommend you use any household cleaners to clean the product. The product should only be cleaned with soapy water, rinsed with clean water, and dried with a soft cloth.

Please see our website www.bathstore.com for any assistance