

INSTALLATION GUIDE

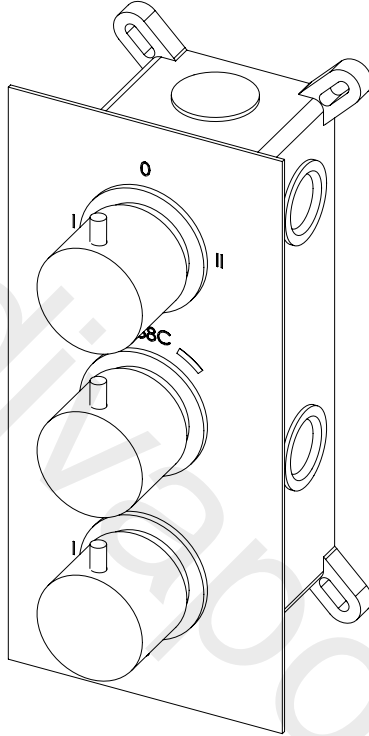

THERMOSTATIC SHOWER MIXER
3 Outlets

IMPORTANT - PLEASE READ

Please read these instructions carefully before starting installation and keep for future reference.

Check the product for missing parts or damage before starting installation.

Any alterations made to this product and fittings may infringe water regulations and will invalidate the guarantee.

The installation must comply with all Local/National Water Supply Authority Regulations/Byelaws and Building and Plumbing (UK:BS6700) Regulations.

This product should only be fitted by a qualified plumber, it may invalidate the guarantee if fitted by a non-qualified person.

Specification

Minimum Pressure	0.5 bar
Maximum Pressure	5.0 bar
Recommended pressure	1.0-3.0 bar balanced
Inlets	G3/4" Hot and Cold
Outlets	2x G3/4" Mixed and 1x G1/2" Mixed
Hot Supply Temperature	55-65 °C
Cold Supply Temperature	4-20 °C

GENERAL INSTALLATION

This shower valve is a mixing device so the inlet pressures must be reasonably balanced.

For ease of maintenance it is recommended that isolation valves are fitted to the inlet feeds.

All supply pipes **MUST** be thoroughly flushed to remove any debris prior to making any connection to the valve. Failure to do so could result in damage or low flow from the mixer unit.

The valve is supplied with a cover plate as protection during fitting, this should remain in place until second fixing.

Note: When pressure is higher than 5 bar a pressure reducer is required to be fitted before the valve.

Typical installation showing depth of the valve from finished wall surface

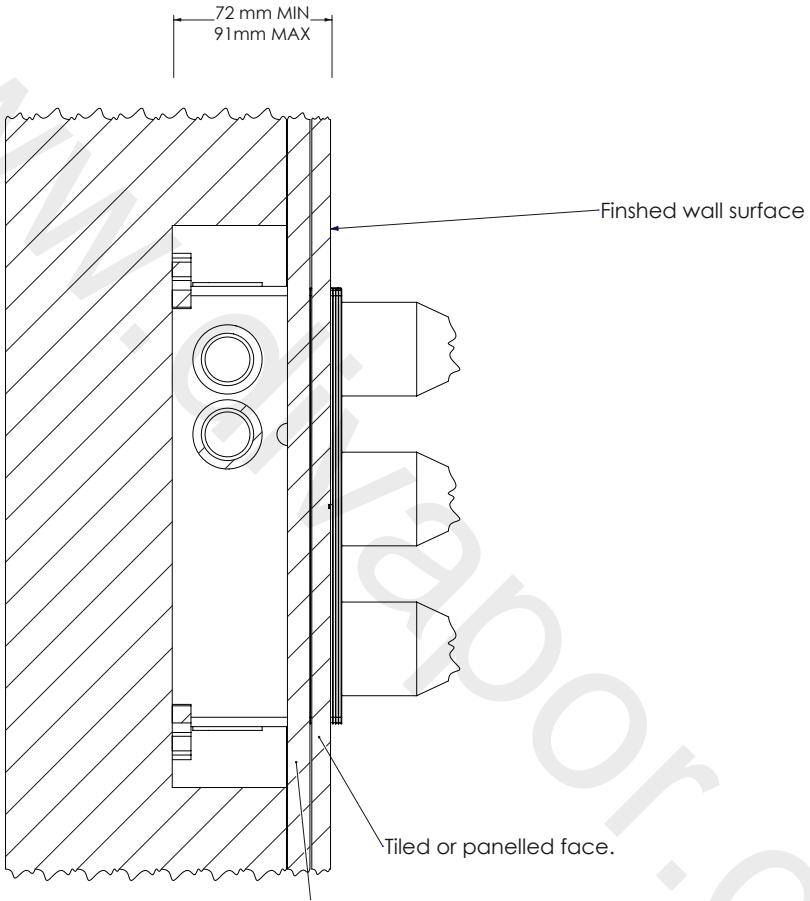

Dimensions first fix - valve body

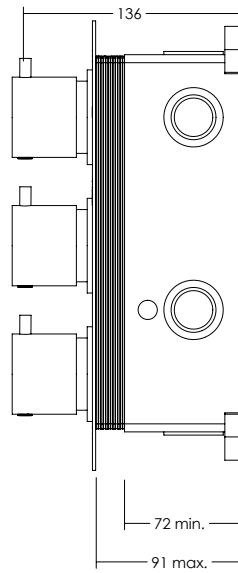
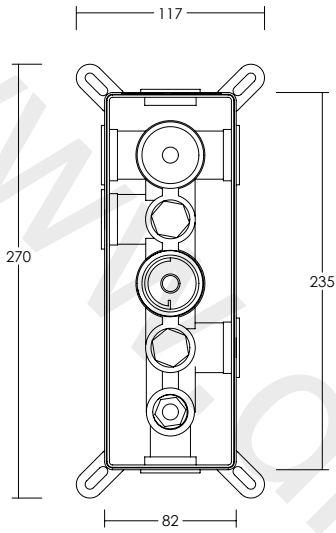

Dimensions as fitted

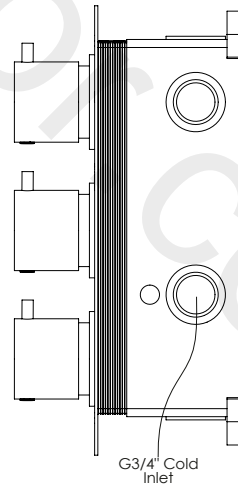
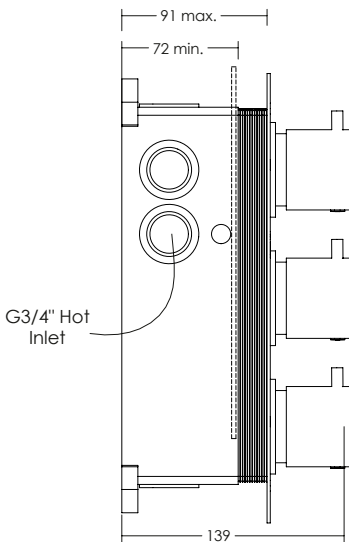

3 Way Outlet

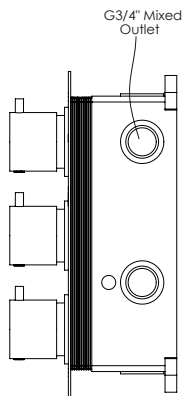
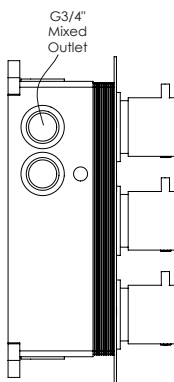
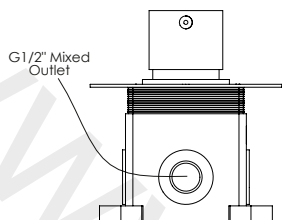

Fascia Plate

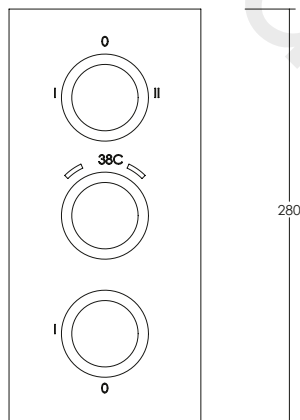

Handle Pack

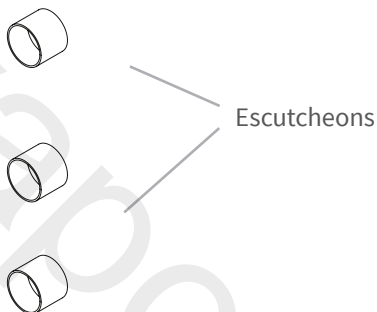

Handle Pack - according to choice

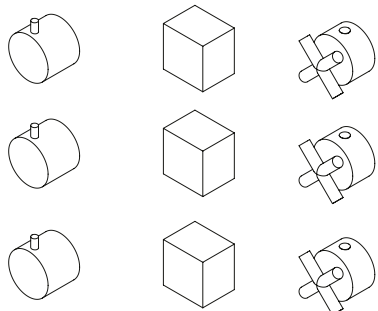

INSTALLATION STEPS

1

Select the position for the shower valve and offer the shower valve to the wall.

Make sure the valve is set back to the appropriate depth from the finished wall surface, allowing for boarding and tiling. For stud walls a batten or suitable fixing plate can be used.

Ensure the valve is vertical with a level and mark the 4 fixings. Prepare the supply and outlet pipes as required.

Fix the valve in place and connect the pipework.

Note: It is recommended that isolation valves are fitted to the inlet feeds.

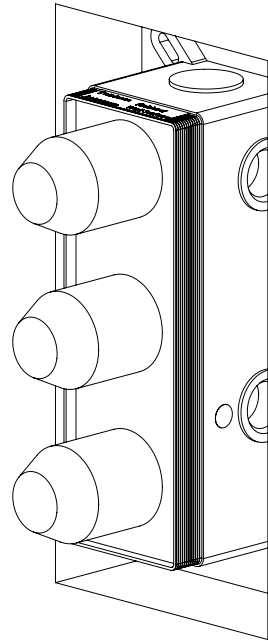

2

Board the wall, we recommend a suitable waterproof board is used and seal the edges of the Easi-Box.

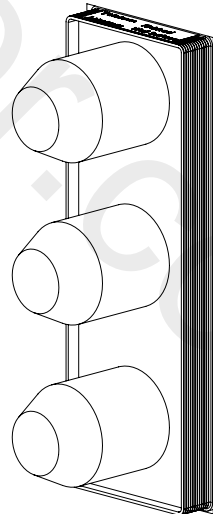

3

Finish the wall by tiling or paneling up to the Easi-Box, keep the final finished wall surface between the min and max guides marked on the Easi-Box.

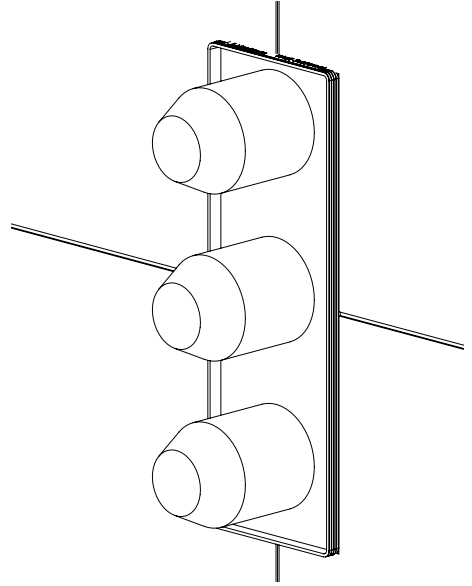

4

Remove the protective cover.

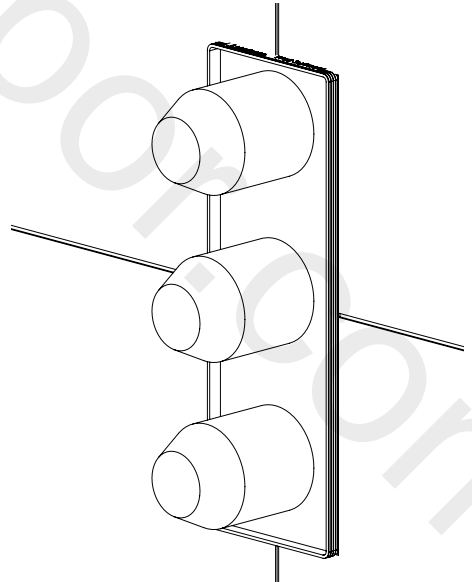

- 5** Trim away any excess from the lip of the Easi-Box using a sharp blade, ensuring that none of the lip protrudes beyond the finished wall surface.

Ensure the stop ring on the thermostatic valve is orientated as indicated in the diagram.

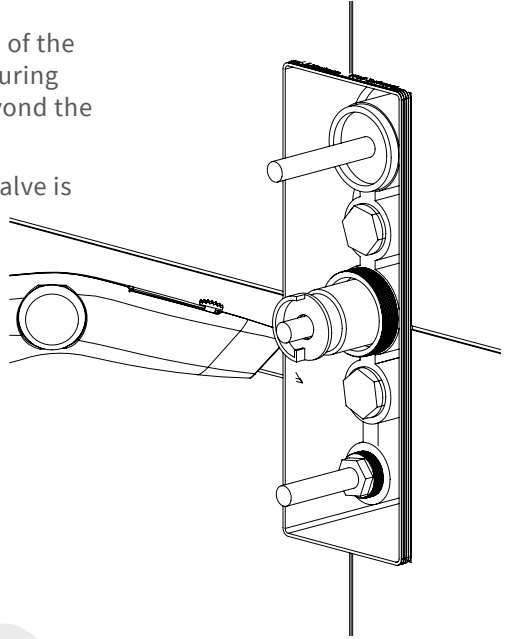

- 6** Attach the escutcheon pieces by screwing onto the threads on the valve body.

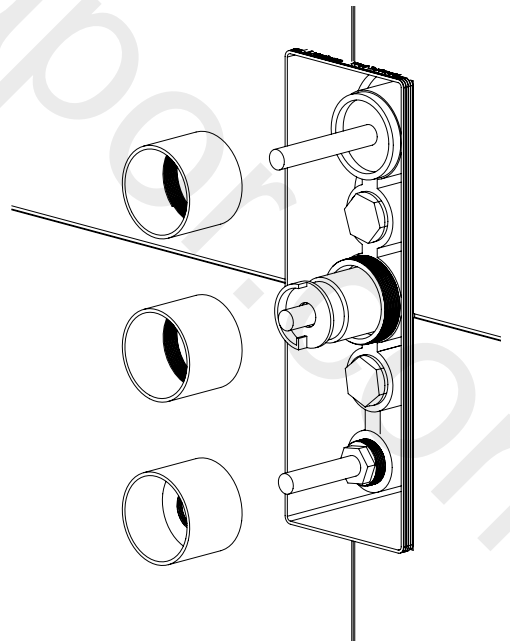

7

Apply a little silicone grease to the O rings of the fascia plate and a narrow bead of silicone sealant to the back and slide into place .

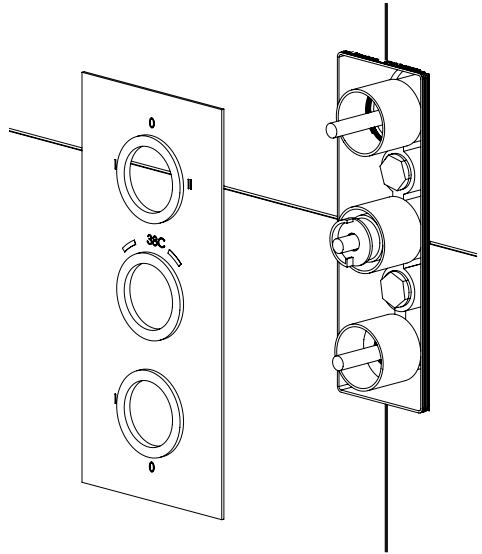

8

Fit the control knobs ensuring the stop pin of the temperature handle is located against the top of the stop ring.

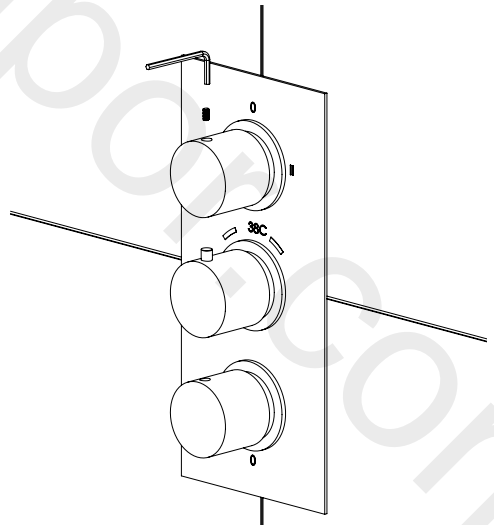

9

Re-calibration

The valve is factory set under balanced pressure with specific inlet temperatures.

As site conditions may differ, the temperature may require re-setting according to site conditions.

Remove the temperature handle and turn on the valve and allow the output temperature to stabilise.

Turn the spindle until a constant temperature of 38°C is achieved.

Ensure the stop ring is fitted correctly as indicated.

Replace the handle so the stop pin sits against the stop ring.

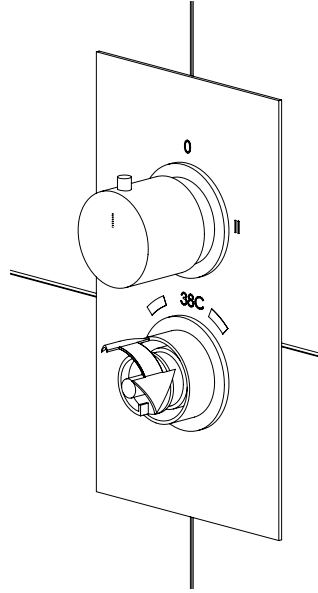

10

Maintenance

Over a period of time limescale and debris can affect the performance of the valve.

It is recommended that regular cleaning is carried out to maintain performance.

Filter Cleaning

Turn off the water supply. Remove the handles and face plate. Remove the filter covers (A) and remove the filters and non-return valves then visible.

Run these under hot water and wipe to remove any build of debris.

Thermostat Cleaning

Turn off the water supply. Remove the handles and face plate. Remove the thermostatic valve. Run the thermostatic valve under hot water and wipe to remove any build of debris.

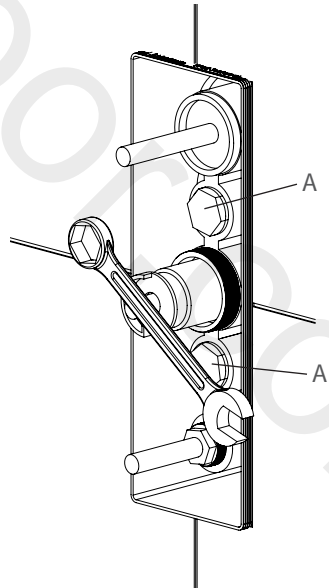

www.divapor.com