

# Mira Sport Max with Airboost

9.0 & 10.8 kW

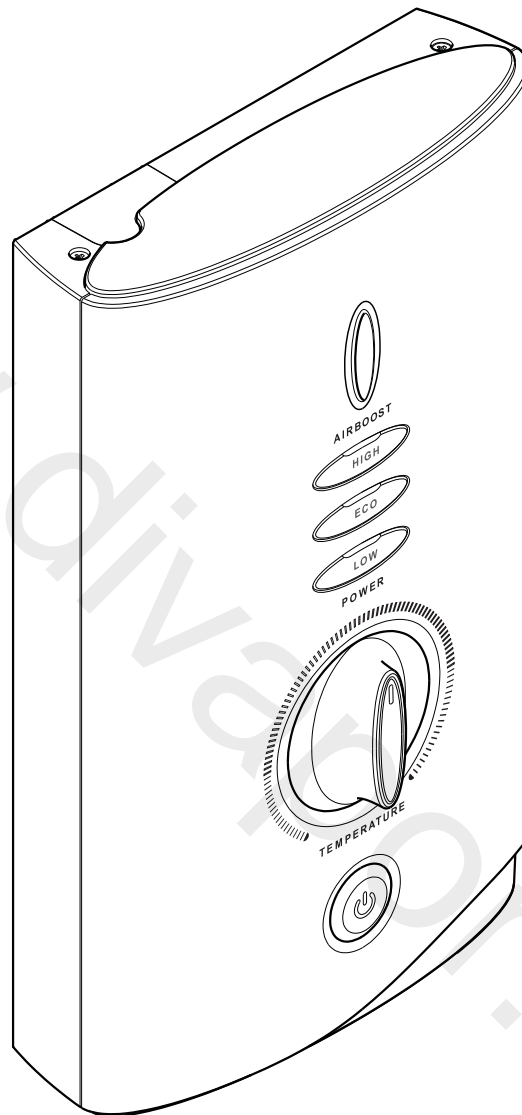

These instructions must be left with the user

Installation Guide

*Showering perfection*

**mira**  
SHOWERS

# INTRODUCTION

Thank you for purchasing a quality Mira Sport Max with Airboost Electric Shower. To enjoy the full potential of your new shower, please take time to read this guide thoroughly, and keep it handy for future reference.

Products manufactured by Kohler Mira Ltd are designed to be safe provided, that they are installed used and maintained in good working order, in accordance with our instructions and recommendations.

Follow all warnings, cautions and instructions contained in this guide, and on or inside the shower.

The Mira Sport Max with Airboost electric showers have separate controls for power selection and temperature/ flow adjustment, in addition an Airboost function further enhances the showering experience. A unique flow regulator stabilises any temperature changes caused by water pressure fluctuations, which can result from taps being turned on or off or toilets being flushed.

When this shower has reached the end of its serviceable life, it should be disposed of in a safe manner, in accordance with current local authority recycling, or waste disposal policy.

## Mira Sport Max with Airboost models covered by this guide:

Product	Model Number	Colour
Sport Max with Airboost 9.0	J03G	White/Chrome
Sport Max with Airboost 10.8	J03H	White/Chrome

## Guarantee

The Mira Sport Max with Airboost has been designed for domestic use only, Mira Showers guarantee the Mira Sport Max with Airboost against any defect in materials or workmanship for a period of two years from the date of purchase (shower fittings for one year).

For terms and conditions, refer to the back cover of this guide.

## Patents and Design Registration

<b>Design Registration:</b>	001259 287-0003
<b>Patents:</b>	GB: 2 341 667, 2 427 460 Ireland: 82835
<b>Patent Application:</b>	Ireland: 2006/0462

If you experience any difficulty with the installation of your new shower, then please refer to “**Fault Diagnosis**”, before contacting Kohler Mira Limited. Our telephone and fax numbers can be found on the back cover of this guide.

# IMPORTANT SAFETY INFORMATION

**WARNING - This shower can deliver scalding temperatures if not operated, installed or maintained in accordance with the instructions, warnings and cautions contained in this guide and on or inside the appliance.**

## **TO REDUCE THE RISK OF FIRE, ELECTRIC SHOCK OR INJURY:**

1. Installation of this shower must be carried out in accordance with these instructions by qualified, competent personnel.
2. Isolate the electrical and water supplies before commencing installation. The electricity must be isolated at the consumer unit and the appropriate circuit fuse removed, if applicable. Mains connections are exposed when the cover is removed.
3. **DO NOT** install the shower in areas with high humidity and temperature (i.e. steam rooms and saunas).
4. **DO NOT** install the shower where it may be exposed to freezing conditions. Ensure that any pipework that could become frozen is properly insulated.
5. **DO NOT** switch the shower on if there is a possibility that the water in the shower is frozen.
6. **DO NOT** switch the shower on if water starts leaking from the shower case. Isolate the electrical supply to the shower immediately.
7. **DO NOT** connect the outlet of the shower to any tap, control valve, trigger handset or showerhead other than those specified for use with this shower. Only Kohler Mira recommended accessories should be used.
8. The water supplies to this product must be isolated if the product is not to be used for a long period of time. If the product or pipework is at risk of freezing during this period they should also be drained of water.
9. **DO NOT** perform any unspecified modifications to the shower or its accessories. When servicing only use genuine Kohler Mira replacement parts.
10. If the shower is dismantled during installation or servicing then upon completion the product must be inspected to ensure all electrical connections are tight and that there are no leaks.
11. Read all installation instructions before installing this shower.
12. Upon completion of the installation, make sure that the user is familiar with the operation of the shower, and leave this guide and the user guide with the owner.

# PACK CONTENTS

Tick the appropriate boxes to familiarise yourself with the part names and to confirm that the parts are included.

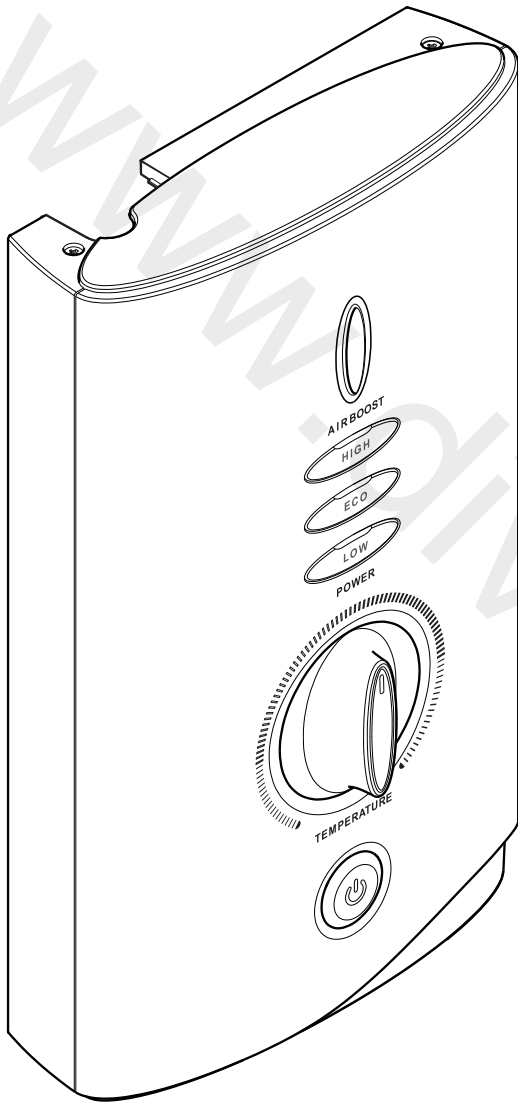

1 x Mira Sport Max with Airboost Electric Shower



1 x Olive



1 x Compression Nut

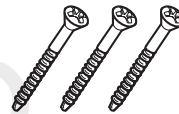

3 x Fixing Screws



3 x Wall Plugs

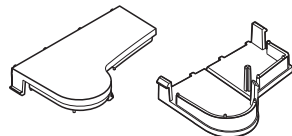

2 x Case Inserts

## Documentation

1 x Installation Template

1 x User Guide

1 x Installation Guide

1 x Guarantee Brochure

# WIRING DIAGRAM

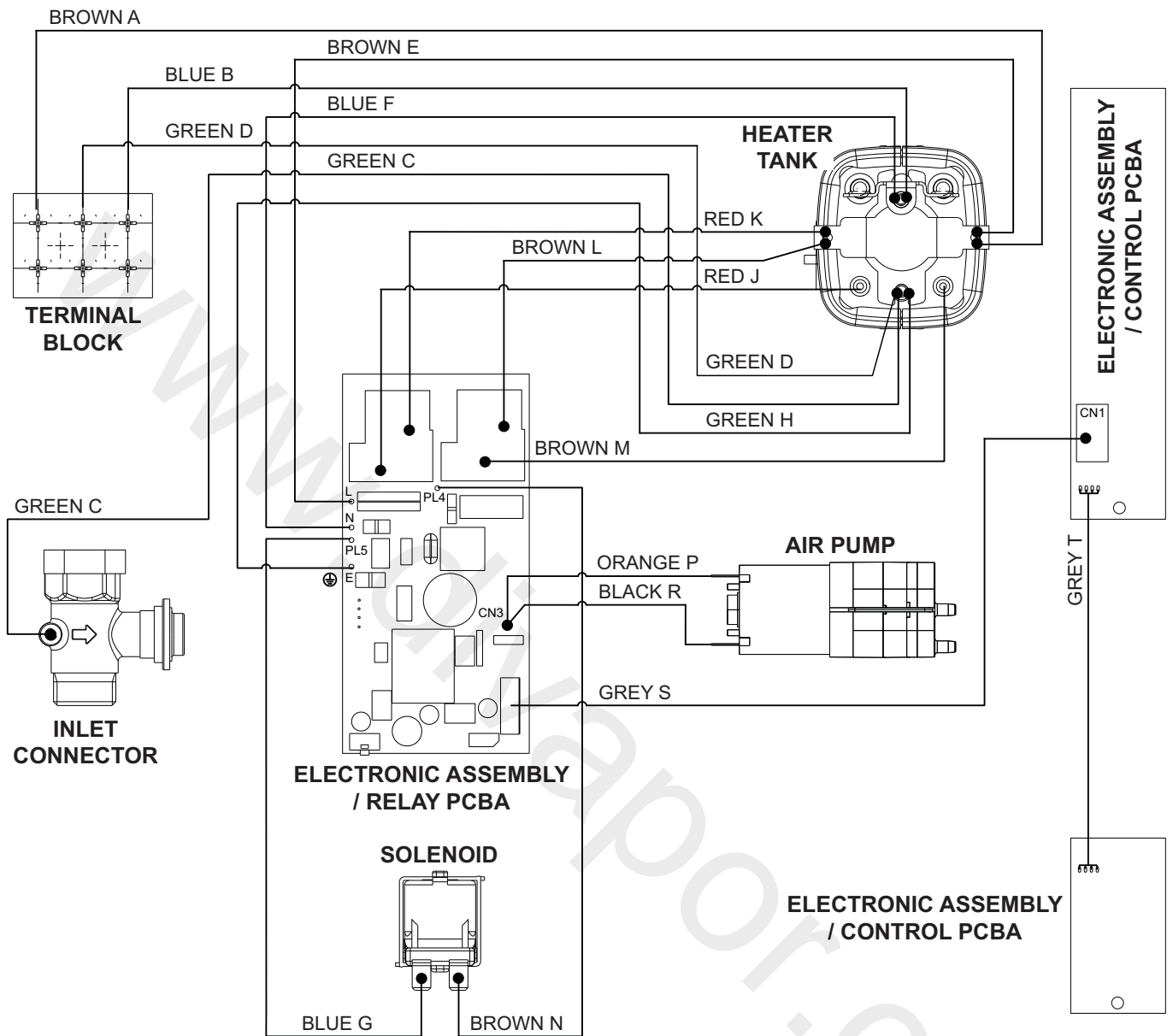

# SPECIFICATIONS

Plumbing	Sport Max with Airboost Variant	
	9.0	10.8
Minimum Dynamic Pressure	70 kPa (0.7 bar)	100 kPa (1.0 bar)
Maximum Dynamic Pressure *	500 kPa (5 bar)	
Minimum Static Pressure	20 kPa (0.2 bar)	
Maximum Static Pressure *	1000 kPa (10 bar)	
Maximum Inlet Temperature	30°C	
Minimum Inlet Temperature	2°C	
Inlet Connection	1/2" BSP Male / 15 mm Compression Fitting	
Maximum Water Hardness	200 ppm CaCO <sub>3</sub>	
Outlet Connection	1/2" BSP Male	

Electrical	Sport Max with Airboost Variant	
	9.0	10.8
Nominal Power at 230 V ac	8.3 kW	9.9 kW
Nominal Power at 240 V ac	9.0 kW	10.8 kW
Recommended MCB Rating	40 A	45 A
Maximum Supply Cable Size	16 mm <sup>2</sup>	
Recommended RCD Rating	30 mA tripping current	
Recommended Isolator Switch	45 A double-pole with 3 mm contact separation	
Appliance Sealing Rating	IP X4 - Suitable for installation in Zone 1	
Maximum Ambient Temperature	30°C	
Minimum Ambient Temperature	2°C	

Dimensions	
Height	358 mm
Width	215 mm
Depth	90 mm

\*A drop tight pressure reducing valve should be installed where dynamic or static pressure exceeds the figure stated in the Specifications.

## European Conformity Information

The Mira Sport Max with Airboost range of showers complies with the following European directives:

2006/95/EC Low Voltage Directive, 2004/108/EC EMC Directive.

The Mira Sport Max with Airboost range of showers are high power appliances and are subject to conditional connection. If the main electrical supply fuse is rated less than 80 Amps, the local electricity supply company must be contacted to confirm if the electrical supply is adequate.

The Mira Sport Max with Airboost range of showers complies with the requirements of the UK's water regulations.

# INSTALLATION REQUIREMENTS

Please read the Important Safety Information and specifications sections at the front of this guide, and the requirements detailed in this section before installing the shower.

**WARNING - TO REDUCE THE RISK OF FIRE, ELECTRIC SHOCK OR INJURY:**

## Plumbing

1. The plumbing installation must comply with all national or local water regulations and all relevant building regulations, or any particular regulation or practice specified by the local water supply company.
2. Do not install the product in a position in which service access is limited.
3. Decide on a suitable position for the shower (minimum distance of 200 mm from the ceiling to allow for cover fit and removal).
4. The position of the shower and shower fittings must provide a minimum gap of 25 mm between the showerhead and the spill over level of any bath, shower tray or basin and a minimum gap of 30 mm between the showerhead and the spill over level of any toilet, bidet or other appliance with a Fluid Category 5 backflow risk (see diagram on page 8).
5. The shower is suitable for installation within the shower area and is fitted with a pressure relief valve. It must be positioned over a water catchment area with the controls at a convenient height for the user.
6. The shower must be fitted to a waterproof flat and even wall surface.
7. **DO NOT** fit the shower to the wall and tile up to the case.
8. **DO NOT** seal the gap between the shower and the wall surface.
9. The showerhead should be positioned so that it discharges down the centre line of the bath or across the opening of a shower cubicle.
10. The showerhead must be directed away from the shower unit, during normal use the showerhead must not spray directly on to the shower unit.
11. **DO NOT** apply excessive force to plumbing connections; always provide mechanical support when making plumbing connections. Any soldered joints should be made before connecting the shower.
12. This shower is not designed to be plumbed directly from the rear. For rear-entry supply, add an elbow to the supply pipe and connect as a rising or a falling supply.
13. If pipework and/or electrical cables enter the shower from the rear through a hole in the wall provision must be made to prevent water ingress back into the wall structure.
14. Only use the inlet connector supplied with the shower. **DO NOT** use any other type of fitting.

15. A full bore/non restrictive servicing valve must be fitted in a readily accessible position adjacent to the shower to facilitate maintenance of the shower.  
**DO NOT** use a valve with a loose washer plate (jumper) as this can lead to a build up of static pressure.
16. A water treatment device should be installed where the water hardness may exceed 200 ppm. Malfunctions caused by excessive limescale formation are not covered by this shower's guarantee (see back page for details).
17. The installation must not cause the hose to be sharply kinked during normal use.
18. **DO NOT** perform the electrical installation until the plumbing has been completed and checked for leaks.

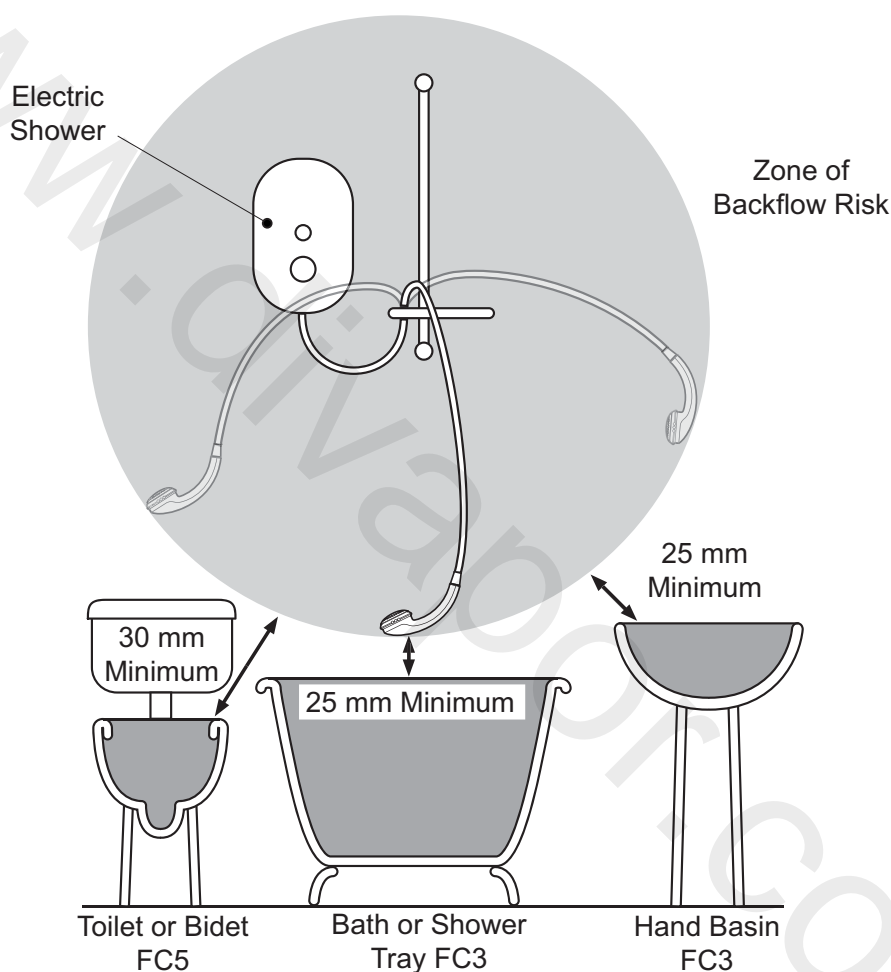

**Hose Retaining Ring fitted and shower fittings fixed at a suitable height preventing dirty water backflow.**

**Note!** There will be occasions when the hose retaining ring will not provide a suitable solution for Fluid Category 3 installations, in these instances an outlet double checkvalve must be fitted, this will increase the required supply pressure typically by 10kPa (0.1 bar). Double checkvalves fitted in the inlet supply to the appliance cause a pressure build up, which affect the maximum static inlet pressure for the appliance and must not be fitted. For Fluid category 5 double checkvalves are not suitable.

## WARNING - TO REDUCE THE RISK OF FIRE, ELECTRIC SHOCK OR INJURY:

### Electrical

1. The electrical installation must comply with BS 7671 (commonly referred to as the IEE Wiring Regulations) and all relevant building regulations, or any particular regulation or practice specified by the local electricity supply company.
2. Ensure that all circuit protection devices, switches and cabling is adequate for the rated current of the shower and that the rating of the electricity supply company fuse and the consumer unit are adequate for the additional demand.
3. The shower **must** be earthed. Ensure any supplementary bonding complies with the relevant regulations.
4. This shower is intended to be permanently connected to the fixed electrical wiring of the mains system. A separate supply **must** be provided from the consumer unit to the shower.
5. **DO NOT** supply any other electrical equipment including extractor fans or pumps via this product.
6. This shower must be provided with means for local disconnection that is incorporated into the fixed wiring in accordance with the relevant local wiring regulations. This **must** be a double pole switch, which has at least 3 mm contact separation in each pole. The switch can be a ceiling mounted pull-cord type within the shower room or a wall mounted switch fitted in the applicable zone area.
7. A 30mA Residual Current Device (RCD) must be incorporated into the electrical supply to this shower in accordance with wiring regulations.
8. **DO NOT** apply excessive force to the terminal block.
9. All electrical connections should be checked for tightness to prevent overheating before switching on the electrical supply.
10. **DO NOT** switch on the electrical supply until the plumbing has been completed and checked for leaks.

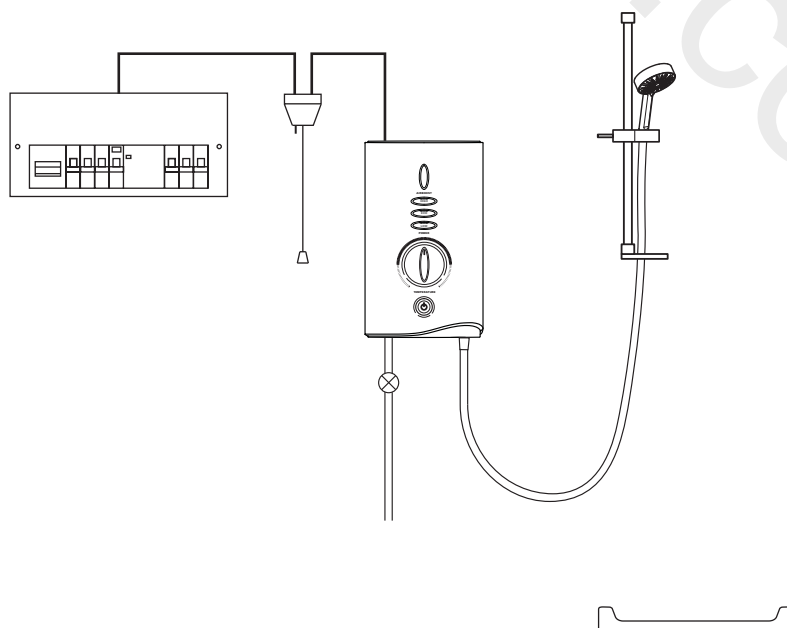

Plumbing and Electrical Schematic

# INSTALLATION

**Warning!** Isolate the electrical and water supplies before installing the shower.

**1** Remove the three screws that hold the cover on and remove the cover.

**2** Remove the service tunnel.

**3** Using the installation template supplied, mark the positions of the **three** fixing holes.

**Note!** Ensure that there are sufficient lengths of supply pipe and electrical cable to reach the connection points.

**4** Remove the installation template and drill three holes to suit the fixing screws and wall plugs.

**Caution!** Do not drill into cables or pipes in the wall.

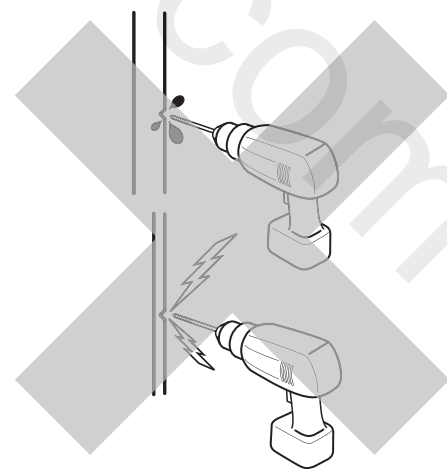
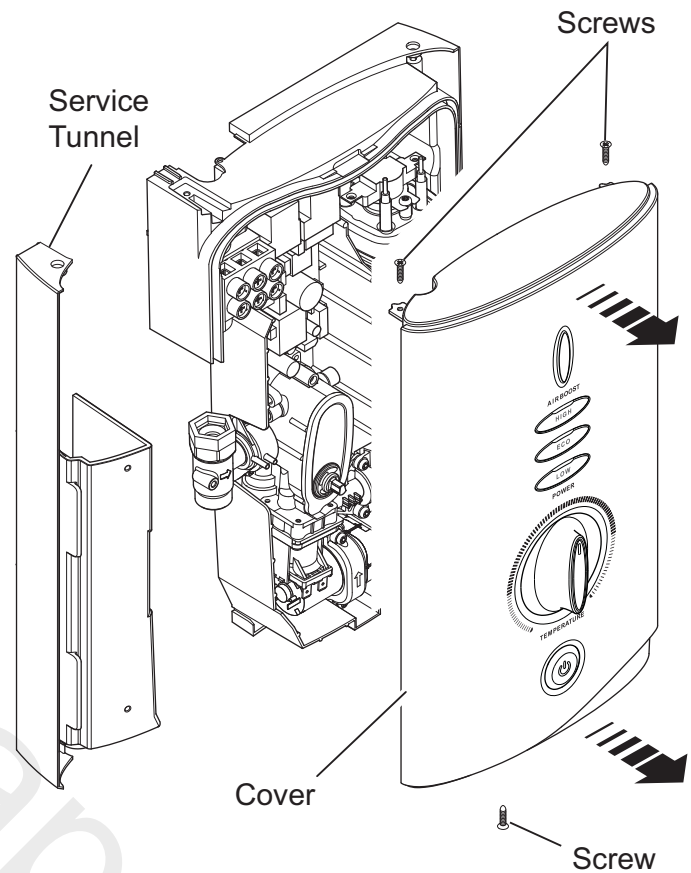

**Caution!** Do not drill into buried cables or pipes.

- 5** Determine the direction and route of the incoming water supply: falling (entering the shower from the top), or rising (entering the shower from the bottom).

**NOTE!** - **DO NOT** use an incoming supply entering the shower directly from the back. Add an elbow to the supply pipe and connect it as a rising or falling supply.

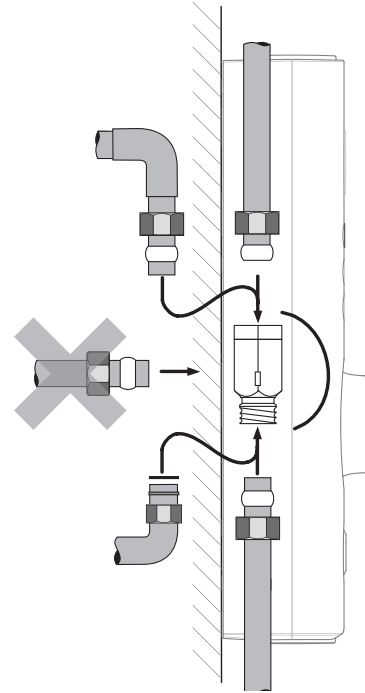

- 6** Thoroughly flush the supply pipe.

- 7** Rotate the inlet connector to suit the direction of the incoming water supply.

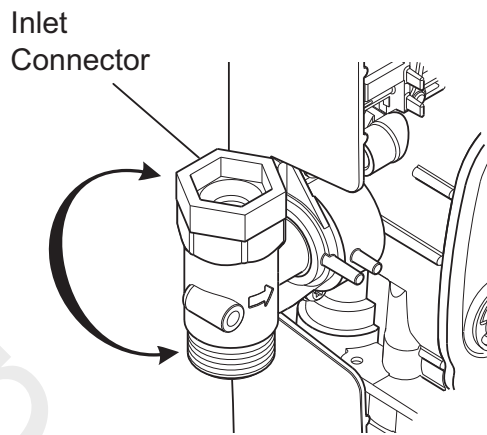

- 8** Upper and lower case inserts are supplied and should be fitted.  
**NOTE!** - Trim the inserts if necessary to fit incoming electrical or water supplies before fitting.

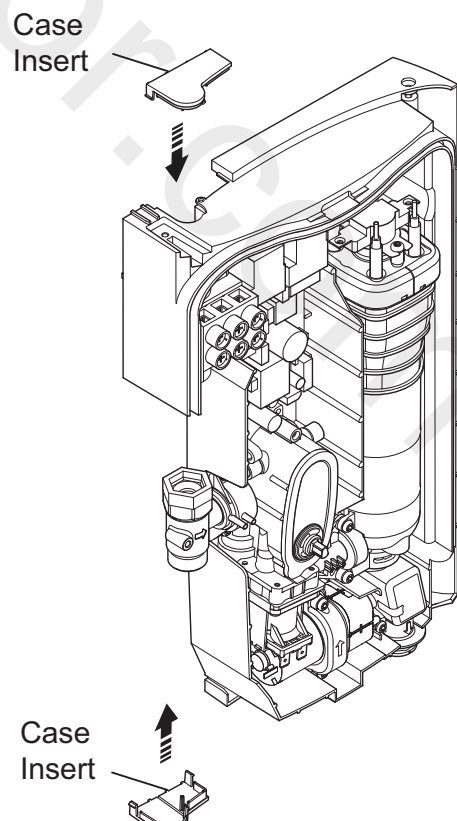

- 9** Secure the shower to the wall.

- 10** Connect the inlet supply pipe to the inlet connector using the compression nut and olive (supplied). Always provide mechanical support when making plumbing connections. Upon completion of the installation ensure connections and back case are not under any stress due to misaligned pipework or electrical cables.

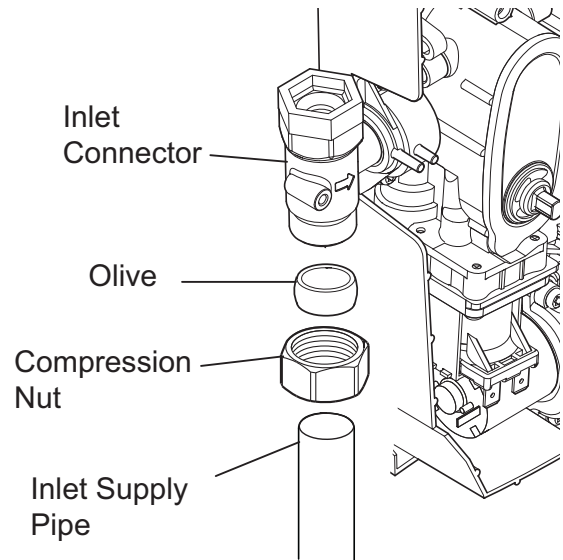

- 11** Turn on the water supply and check for leaks.

- 12** Strip back sufficient outer cable insulation to enable routing to terminal block.

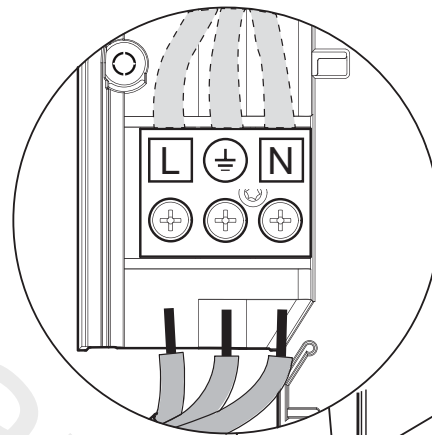

- 13** Fit an earth sleeve to the earth wire.

- 14** Loosen the screws in the terminal block and insert the wires.

- L** (Live) = Brown wire
- ⊕** (Protective Earth) = Green / Yellow sleeved wire
- N** (Neutral) = Blue wire

- 15** Tighten the screws in the terminal block, ensure the wires are secure and tight.

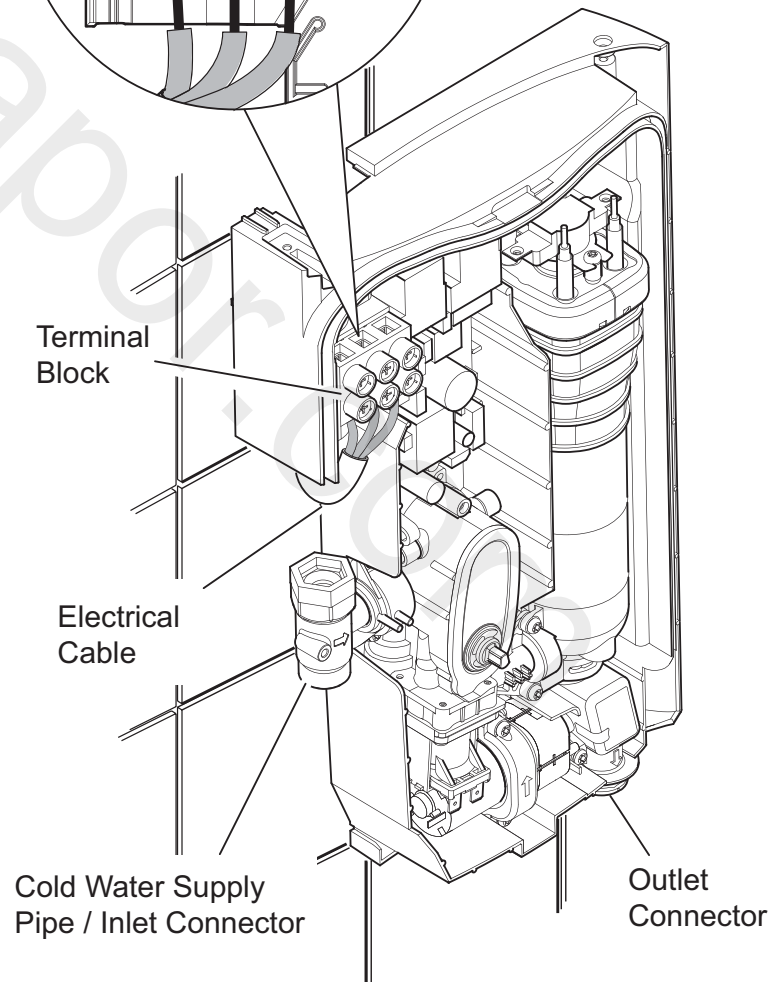

**16** Ensure the earth bonding complies with relevant regulations.

**17** Replace the service tunnel.

**18** Plug the multi-connector into the cover PCB socket **Note!** The multi-connector will only locate correctly into the socket in one direction.

Ensure the temperature control dial is aligned with the spindle then replace the cover.

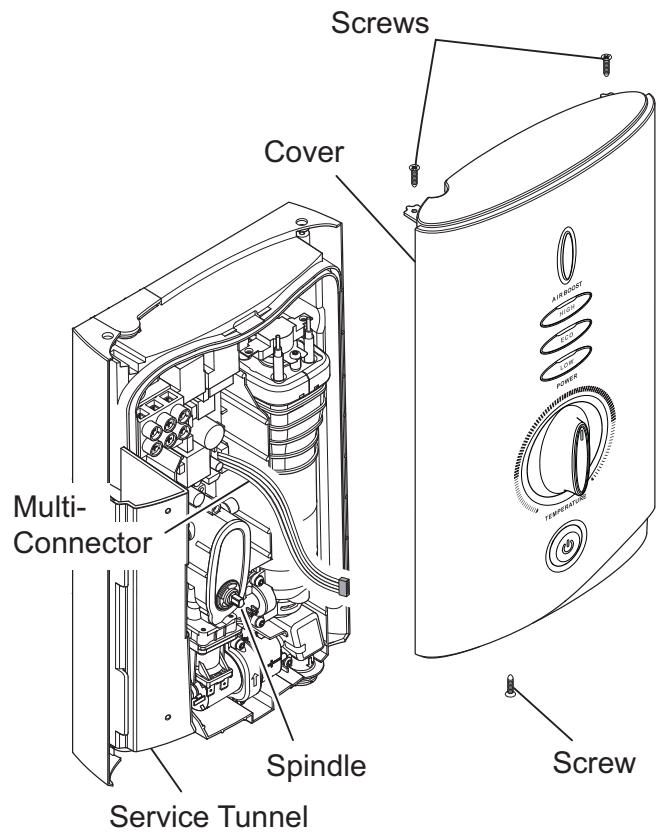

**19** Tighten the three cover screws.

**20** **Do not** use alternative screws to secure the cover. This can cause internal damage to the appliance.

**Do not** seal around the back of appliance.

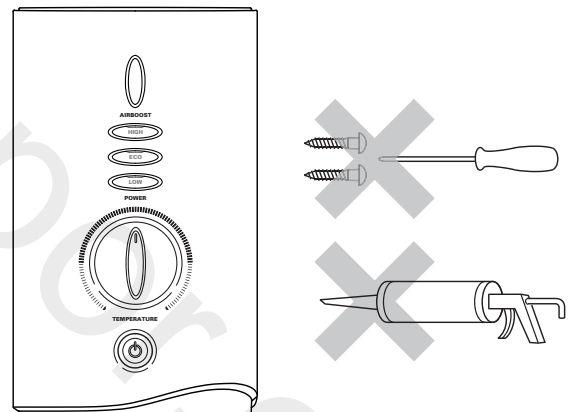

**21** To enable the Airboost function the shower hose must now be fitted correctly. Follow the instructions in the separate guide (Mira Sport Shower Fittings) to install the shower fittings.

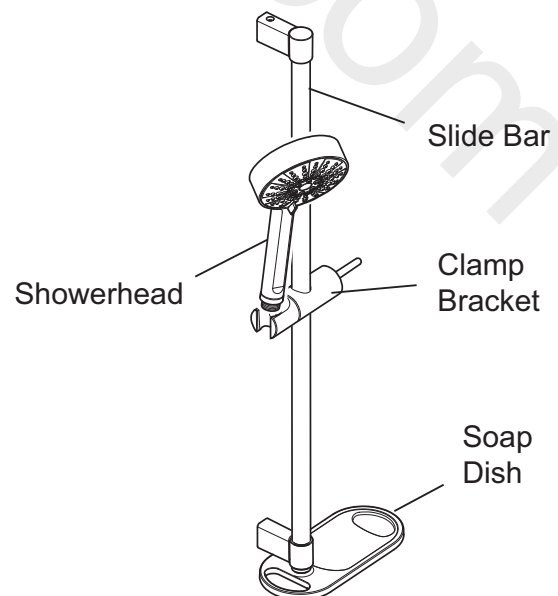

22

Identify the different ends of the air pipe tube:

- Air pipe adapter is inserted into the shower outlet
- Air pipe diffuser is inserted into the showerhead

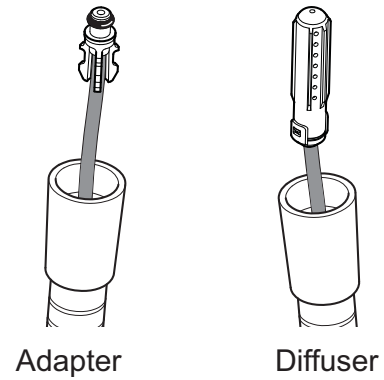

23

Fit the air pipe adapter into the outlet connector, then carefully tighten the shower hose onto the outlet connector.

**Note!** Make sure the hose washer is fitted and that the air pipe is pushed fully home into the outlet connector.

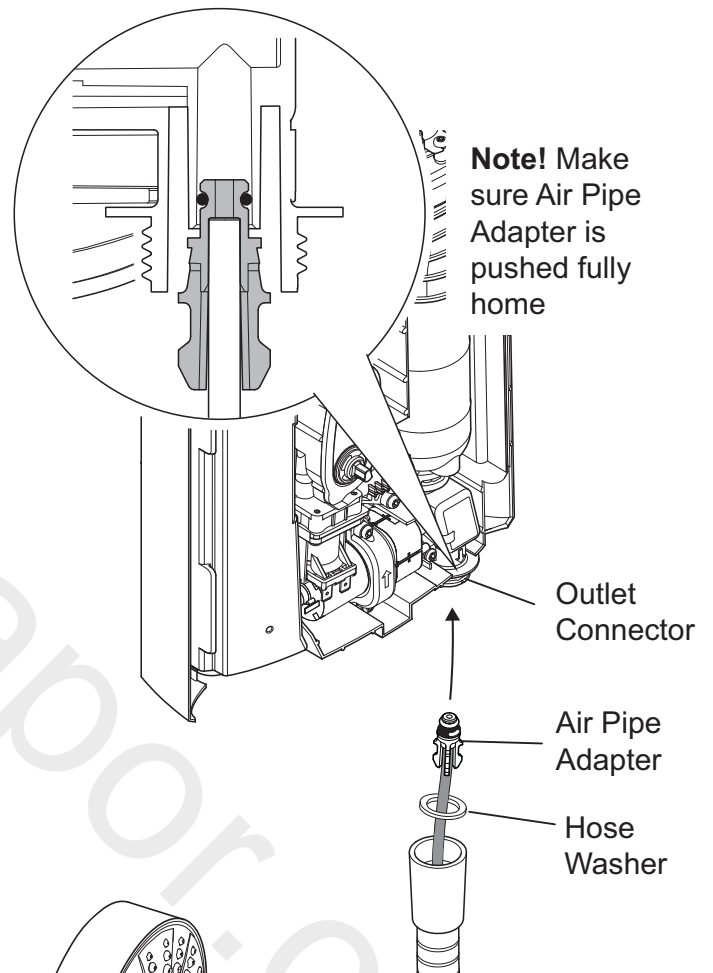

24

Fit the diffuser into the showerhead, then carefully tighten the shower hose onto the showerhead.

**Note!** Make sure the hose washer is fitted and that the diffuser is pushed fully home into the showerhead.

25

Fit the showerhead into the clamp bracket.

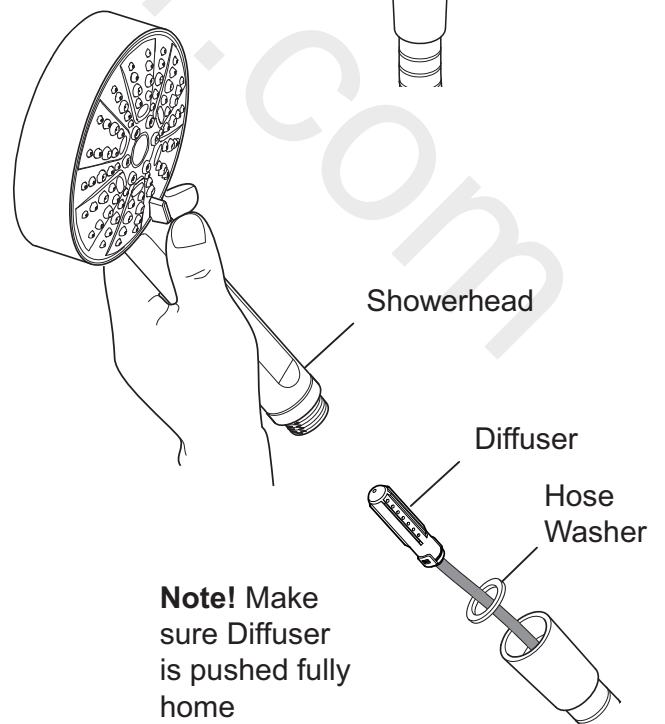

26

This completes the installation, follow the guidelines in section '**COMMISSIONING**' to prepare the shower for use.

# COMMISSIONING

1

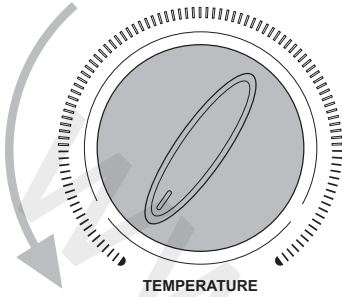

Turn temperature control to the cold position.

2



Switch on the electrical supply.

3

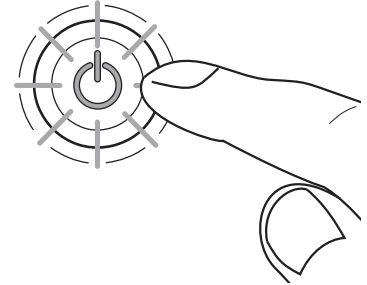

Push START/STOP button. Light in the button illuminates.

4

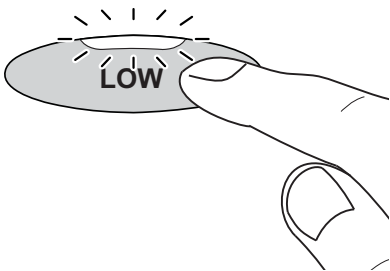

Push LOW button. Low button illuminates.

5

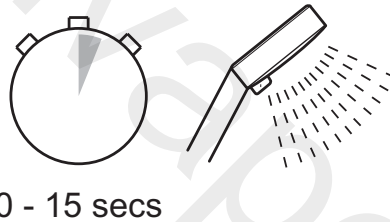

0 - 15 secs

Water flows freely within a few seconds, temperature remains cool.

6

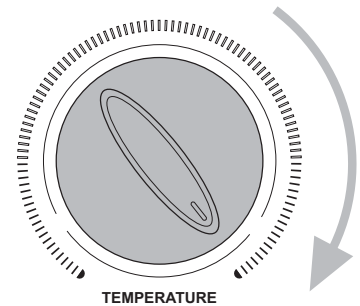

Slowly turn the temperature control to the hot position.

7

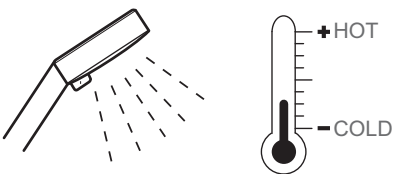

Flow is reduced and temperature remains cool.

8

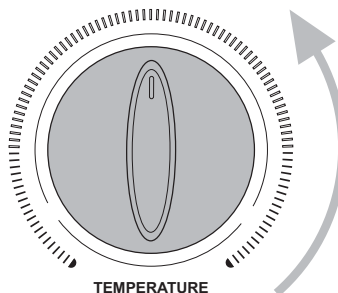

Turn temperature control back to the midway position.

9

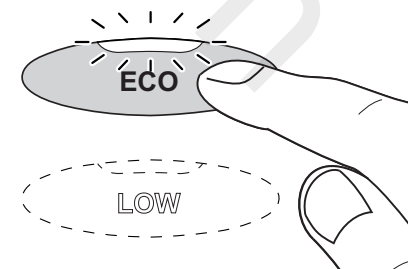

Push ECO button. Eco button illuminates

10

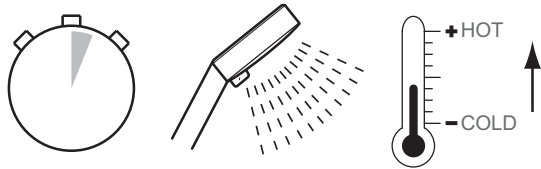

5 - 10 secs

Temperature will rise slightly.

11

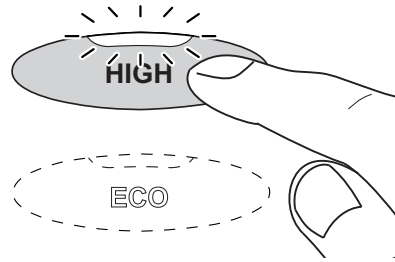

Push HIGH button. High button illuminates

12

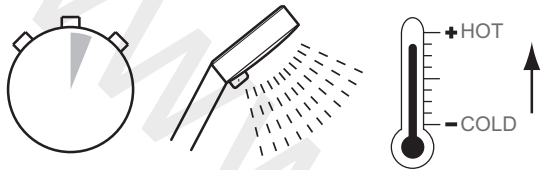

5 - 10 secs

Temperature will rise further.

13

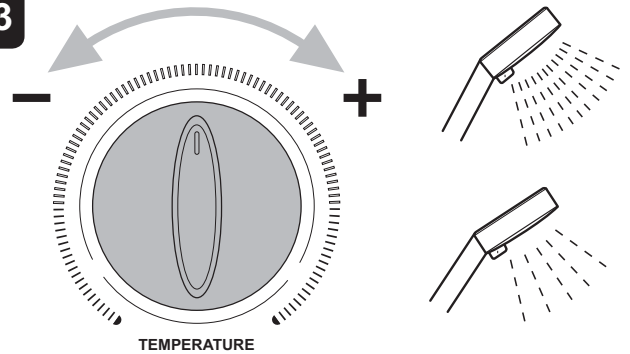

Adjust temperature as required. Flow rate will adjust automatically.

14

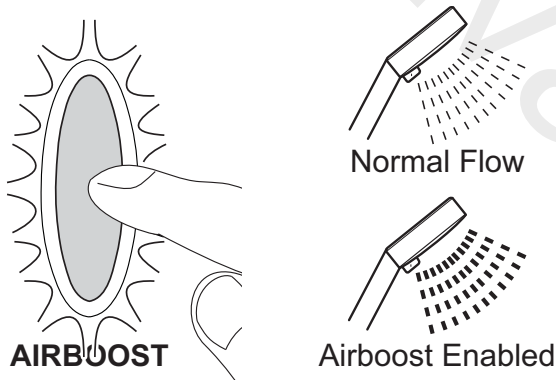

Check Airboost function. Aerated water will flow from the Showerhead.

15

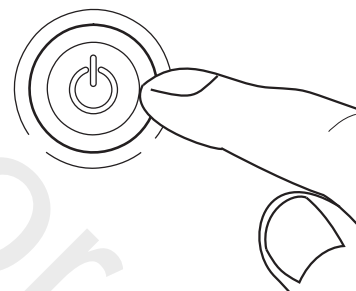

Push START/STOP button. Light in the button goes out.

16

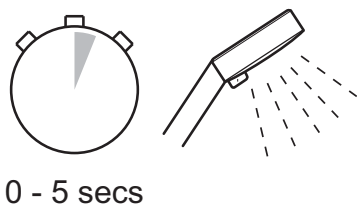

0 - 5 secs

The shower will purge water from its tank for a few seconds.

17



Switch off the electrical supply.

**Note!** When the shower is **not** running or the STOP button has been pressed, the three white power button lights will fade to off after a short time, indicating the shower has entered a "stand-by" mode. A slight hissing sound may also be heard from the shower during operation. High mains water pressure and high shower temperatures will affect the tone. This is quite normal in use.

# FAULT DIAGNOSIS

In the event of a malfunction of the shower, the troubleshooting information below provides details on possible causes and remedies that may be carried out by qualified, competent personnel. Non-qualified personnel should refer to the fault diagnosis section in the users guide.

## WARNING

**There are no user serviceable components beneath the cover of the shower. Only qualified competent personnel should remove the front cover**

Symptom	Start/Stop Light is ON or OFF	Power Control Position	Possible Cause	Possible Remedy
Shower fails to operate.	OFF	ANY	<p>Isolator switch in the off position.</p> <p>Fuse blown or MCB/RCD tripped, indicating possible electrical fault.</p> <p>Service tunnel or cover not fitted correctly.</p> <p>Multi-Connector not plugged into cover PCB.</p>	<p>Switch on electrical supply via the pullcord or wall mounted switch.</p> <p>Renew the fuse or reset the MCB/RCD. If fault persists, contact your installer.</p> <p>Check case inserts are cut and fitted correctly. Check services (electrical or plumbing) are not interfering with location of service tunnel or cover.</p> <p>Connect or re-connect Multi-Connector into cover PCB.</p>
Shower cycles from hot to cold.	ON	ECO/HIGH	<p>Showerhead blocked.</p> <p>Hose kinked or blocked.</p> <p>Water pressure below minimum required for shower operation.</p> <p>Temperature control or power control setting too high.</p>	<p>Remove and descale showerhead.</p> <p>Check hose and replace if necessary.</p> <p>Make sure incoming mains water stopcock and/or shower isolating valve is fully turned on.</p> <p>Turn the power control to Eco or turn the temperature control until a cooler temperature is achieved.</p>
Unable to select a cool enough shower.	ON	ANY	<p>Due to the rise in mains water supply temperature, the power control setting may be too high.</p>	<p>Turn the power control to Eco or turn the temperature control until a cooler temperature is achieved.</p>

Symptom	Start/Stop Light is ON or OFF	Power Control Position	Possible Cause	Possible Remedy
Showerhead dripping.	OFF	ANY	Insufficient water supply pressure for shut off.  Flow valve faulty.	Minimum static pressure to ensure shut off and prevent dripping is 20 kPa (0.2 bar). <b>Note!</b> If other appliances are operating, static pressure may drop below 20 kPa (0.2 bar). Contact local water company.  Replace flow valve.
Low or no flow.	ON	ANY	Water supply pipework or inlet filter restricted by a blockage or partial blockage.  Insufficient water supply pressure/flow for operation.  Flow valve faulty.  Heater tank excessively scaled.  Showerhead blocked.  Hose kinked or blocked.  Other outlets (e.g. toilet, garden hose, washing machine, etc.) drawing water while the shower is being used.	Flush supply pipe. Clean inlet filter.  Contact local water company. Supply pressure must be a minimum of 70 kPa (0.7 bar). <b>Note!</b> If other appliances are operating, pressure may drop below 70 kPa (0.7 bar).  Replace flow valve.  Replace heater tank. In hard water areas consider the use of a water softener.  Remove and descale showerhead.  Check hose and replace if necessary.  Turn off other appliances whilst shower is in use.
Operation of Temperature Control has little or no effect on water temperature.	ON	ECO/ HIGH	Showerhead blocked.  Hose kinked or blocked.  Flow valve faulty.  Heater tank failure.	Remove and descale showerhead.  Check hose and replace if necessary.  Replace flow valve.  Replace heater tank.

Symptom	Start/Stop Light is ON or OFF	Power Control Position	Possible Cause	Possible Remedy
No change in temperature between Low / Eco / High setting.	ON	ANY	Microswitch failure. Insufficient mains water pressure. Possible failure of flow valve, microswitch or heater tank.	Replace microswitch. Contact local water company. Use a suitable device to check the continuity of the microswitch or heater tank and replace parts as necessary.
Water will not turn off.	OFF	ANY	Flow valve, solenoid or Start / Stop switch faulty.	Replace as necessary.
Shower fails to produce hot water when set on Eco / High setting.	ON	ECO/ HIGH	Insufficient water supply. Possible failure of the microswitch or thermal switch.	Contact local water company. Use a suitable device to check the continuity of the microswitch or heater tank and replace parts as necessary.
Water leaks from the bottom of the case and there is no flow from the showerhead.	OFF	ANY	Hose kinked or blocked. The PRV has been triggered, (the shower has a pressure relief valve assembly to reduce damage if the outlet is blocked or the shower is frozen). When the relief valve operates a small rubber ball is ejected.	Check hose and replace if necessary. Replace heater tank.
Airboost function causes spluttering flow from the Showerhead	ON	ANY	The air pipe inside the hose has become detached from one of the fittings.	Check hose and re-fit either the diffuser or the air pipe adaptor.
Airboost function fails to operate	ON	ANY	Air pump or control electronics faulty.	Check connection plug between air pump and PCB. Replace air pump. Replace PCB.

# SERVICING

## WARNING

There are no user serviceable parts inside the shower.

Servicing of the shower must only be carried out by qualified, competent personnel following the instructions provided in this guide and those provided with any spare part.

Before replacing any parts, ensure that the underlying cause of the malfunction has been resolved.

## Cleaning the Inlet Filter

**Warning!** Isolate the electrical and water supplies before removing the cover.

- 1** Remove the shower hose.  
**Note!** Retain the Hose Washer for further use
- 2** Remove the three cover retaining screws and remove the cover.
- 3** Unplug the multi-connector and place the cover to one side.
- 4** Remove the service tunnel.
- 5** Use a suitable spanner to remove the filter from the inlet connector assembly. Hold a wrench across the flats of the inlet connector assembly to prevent damage to the connector, whilst removing the filter.
- 6** Remove the filter and rinse under a running tap to remove any lodged particles. If necessary, use a kettle descalent in accordance with the manufacturer's instructions.
- 7** Refit the components in reverse order. **Note!** The multi-connector will only locate correctly into the cover socket in one direction.

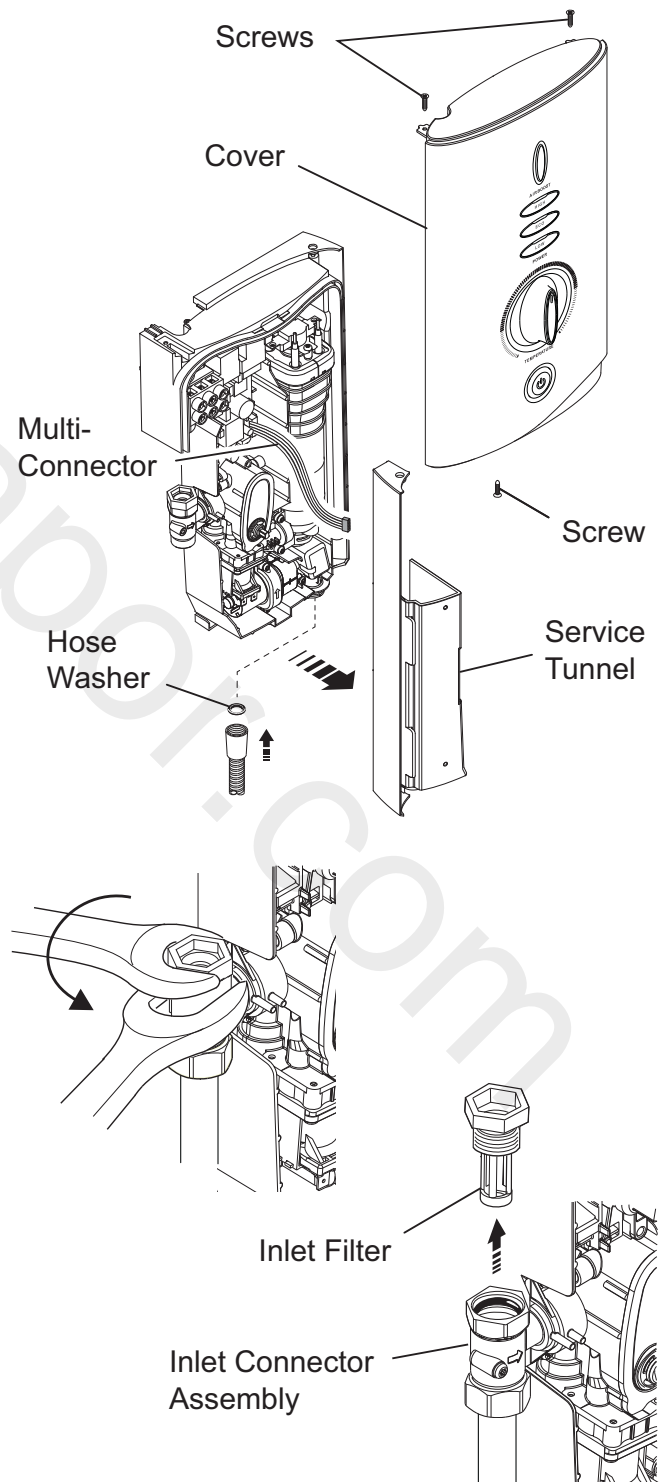

# SPARE PARTS

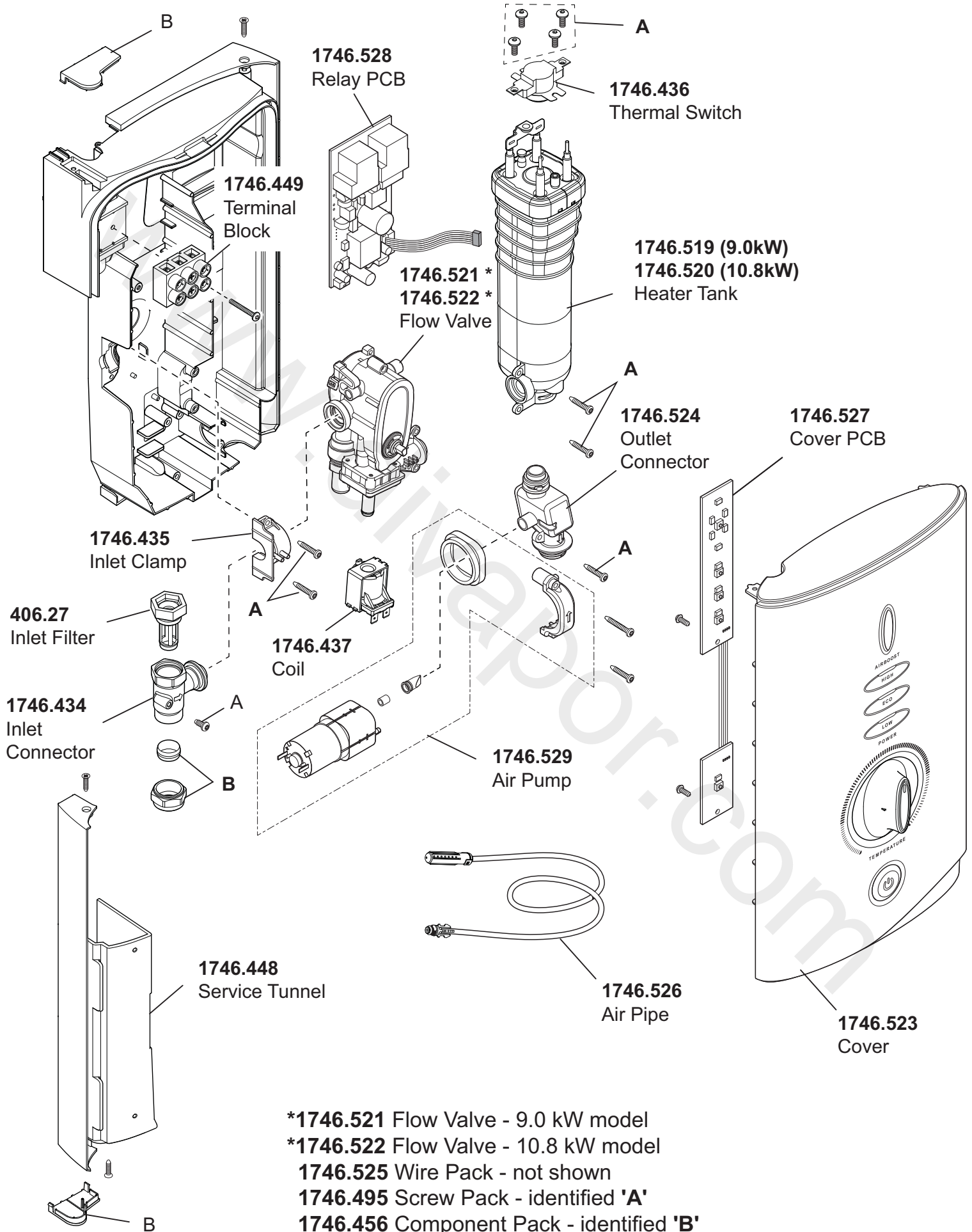

[www.divapor.com](http://www.divapor.com)

[www.divapor.com](http://www.divapor.com)

# CUSTOMER SERVICE

## Guarantee

Your product has the benefit of our manufacturer's guarantee which starts from the date of purchase.

To activate this guarantee, please return your completed registration card, visit our website or free phone 0800 0731248 within 30 days of purchase (UK only).

Within the guarantee period we will resolve defects in materials or workmanship, free of charge, by repairing or replacing parts or product as we may choose.

**This guarantee is in addition to your statutory rights and is subject to the following conditions:**

- The guarantee applies solely to the original installation under normal use and to the original purchaser only. The product must be installed and maintained in accordance with the instructions given in this user guide.
- Servicing must only be undertaken by us or our appointed representative. **Note!** if a service visit is required the product must be fully installed and connected to services.
- Repair under this guarantee does not extend the original expiry date. The guarantee on any replacement parts or product ends at the original expiry date.
- For shower fittings or consumable items we reserve the right to supply replacement parts only.

**The guarantee does not cover:**

- Call out charges for non product faults (such as damage or performance issues arising from incorrect installation, improper use, lack of maintenance, build up of limescale, frost damage, corrosion, system debris or blocked filters) or where no fault has been found with the product.
- Water or electrical supply, waste and isolation issues.
- Compensation for loss of use of the product or consequential loss of any kind.
- Damage or defects caused if the product is repaired or modified by persons not authorised by us or our appointed representative.
- Routine maintenance or replacement parts to comply with the requirements of the TMV 2 or TMV 3 healthcare schemes.
- Accidental or wilful damage.
- Products purchased ex-showroom display.

## What to do if something goes wrong

If your product does not function correctly when you first use it, contact your installer to check that it is installed and commissioned in accordance with the instructions in this manual.

If this does not resolve the issue, contact our Customer Services Team who will offer you or your installer help and advice.

If you experience problems, check in this manual to see if simple home maintenance is required. If you require further assistance call our Customer Services Team.

## Extended Guarantees

A selection of protection plans are available that enable you to cover repair bills for the life of your policy (excludes Eire). Ring 01922 471763 for more details.

## Helpdesk Service

Our Customer Services Team is comprehensively trained and can offer help and advice, spare parts, accessories or a service visit.

We will need you to have your model name or number, power rating (if applicable) and date of purchase. As part of our quality and training programme calls may be recorded or monitored.

## Mira Showers Website ([www.mirashowers.co.uk](http://www.mirashowers.co.uk))

From our website you can register your guarantee, download additional user guides, diagnose faults, purchase our full range of accessories and popular spares, refer to our FAQ's and request a service visit.

## Spares and Accessories

We maintain extensive stocks of genuine spares and accessories and aim to provide support throughout the product's expected life.

Payment can be made by phone at time of order using most major Credit or Debit cards and we aim to despatch orders within 2 working days. Items purchased from us are guaranteed for 12 months from date of purchase. For safety reasons spares exposed to mains voltages should only be fitted by competent persons.

**Returns** – items can be returned within one month of date of purchase, providing that they are in good condition and the packaging is unopened. If you wish to return any items please notify us in writing within seven days of receipt.

## Service / Repairs

We have a nationwide team of Service Technicians can carry out service or repair work to your product within the guarantee period and beyond. You have the assurance of a fully trained Technician, genuine spare parts and a 12 month guarantee on any chargeable work done.

Payment should be made directly to the Service Technician who will accept most major Credit or Debit cards.

## To Contact Us

### UK

**Telephone: 0844 571 5000**

E-mail - Visit [www.mirashowers.co.uk/contactus](http://www.mirashowers.co.uk/contactus)

Fax: 01242 282595

By Post: Mira Customer Services Dept, Cromwell Road, Cheltenham, Gloucestershire, GL52 5EP

### Eire

**Telephone: 01 459 1344**

E-mail: [sales@modernplant.ie](mailto:sales@modernplant.ie)

Fax: Dublin 01 459 2329

By Post: Modern Plant Ltd (Dublin),

Otter House, Naas Road, Clondalkin, Dublin 22

Mira is a registered trade mark of Kohler Mira Limited.

The company reserves the right to alter product specifications without notice.

[www.mirashowers.co.uk](http://www.mirashowers.co.uk)

*Showering perfection*

**mira**  
SHOWERS

# Mira Sport Max with Airboost

9.0 & 10.8 kW

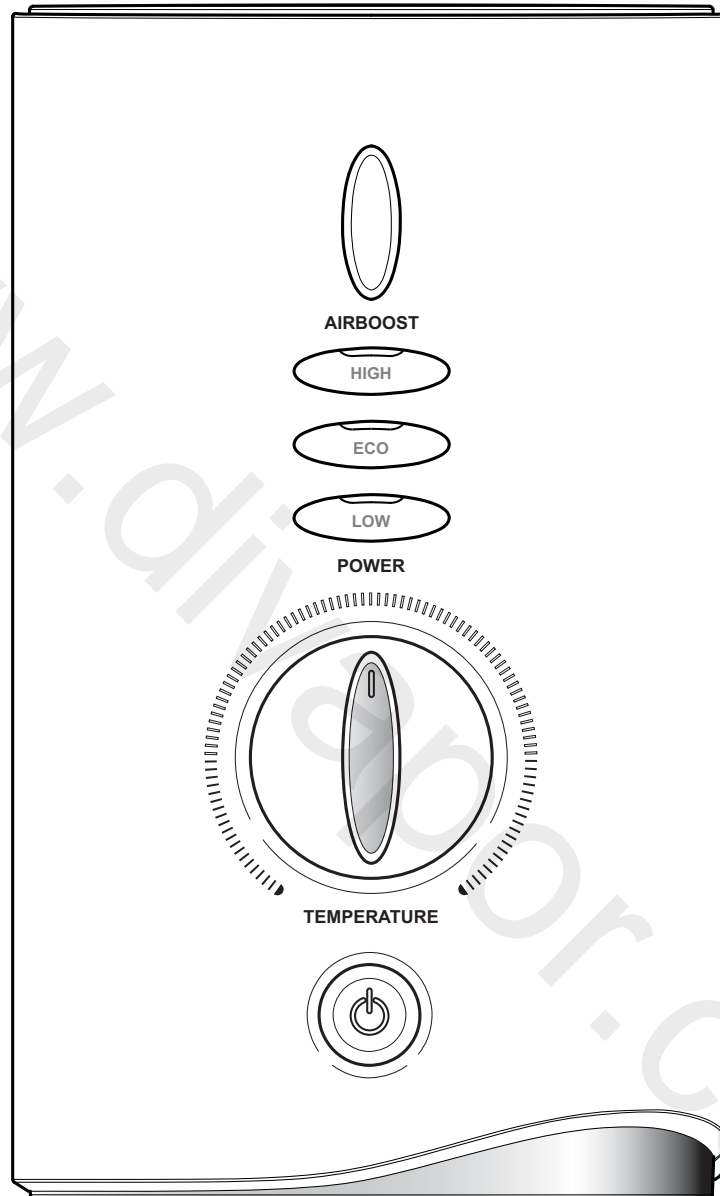

These instructions must be left with the user

User Guide

*Showering perfection*

**mira**  
SHOWERS

# INTRODUCTION

Thank you for purchasing a quality Mira Sport Max with Airboost Electric Shower. To enjoy the full potential of your new shower, please take time to read this guide thoroughly, and keep it handy for future reference.

Products manufactured by Kohler Mira Ltd are designed to be safe provided, that they are installed used and maintained in good working order, in accordance with our instructions and recommendations.

Follow all warnings, cautions and instructions contained in this guide, and on or inside the shower.

The Mira Sport Max with Airboost electric showers have separate controls for power selection and temperature/ flow adjustment, in addition an Airboost function further enhances the showering experience. A unique flow regulator stabilises any temperature changes caused by water pressure fluctuations, which can result from taps being turned on or off or toilets being flushed.

When this shower has reached the end of its serviceable life, it should be disposed of in a safe manner, in accordance with current local authority recycling, or waste disposal policy.

## Mira Sport Max with Airboost models covered by this guide:

Product	Model Number	Colour
Sport Max with Airboost 9.0	J03G	White/Chrome
Sport Max with Airboost 10.8	J03H	White/Chrome

## Guarantee

The Mira Sport Max with Airboost has been designed for domestic use only, Mira Showers guarantee the Mira Sport Max with Airboost against any defect in materials or workmanship for a period of two years from the date of purchase (shower fittings for one year).

For non-domestic installations, Mira Showers guarantee the Mira Sport Max with Airboost against any defect in materials or workmanship for a period of one year from the date of purchase.

For terms and conditions, refer to the back cover of this guide.

## Patents and Design Registration

<b>Design Registration:</b>	001259 287-0003
<b>Patents:</b>	GB: 2 341 667, 2 427 460 Ireland: 82835
<b>Patent Application:</b>	Ireland: 2006/0462

If you experience any difficulty with the operation of your new shower, then please refer to section '**FAULT DIAGNOSIS**', before contacting Kohler Mira Limited.  
Our telephone and fax numbers can be found on the back cover of this guide.

# IMPORTANT SAFETY INFORMATION

**WARNING** - THIS SHOWER CAN DELIVER SCALDING TEMPERATURES IF NOT OPERATED, INSTALLED OR MAINTAINED IN ACCORDANCE WITH THE INSTRUCTIONS, WARNINGS AND CAUTIONS CONTAINED IN THIS GUIDE AND ON OR INSIDE THE APPLIANCE.

**To reduce the risk of fire, electric shock or injury:**

1. Make sure that you fully understand how to operate this shower before use, read all operating instructions and retain this guide for future reference.
2. This shower is not intended for use by persons (including children) with reduced physical, sensory or mental capabilities, or lack of experience and knowledge, unless they have been given supervision or instruction concerning the use of the shower by a person responsible for their safety.
3. Children should be supervised to ensure that they do not play with the shower.
4. **DO NOT** switch the shower on if there is a possibility that the water in the shower is frozen.
5. **DO NOT** switch the shower on if water leaks from the shower unit. Isolate the electrical supply to the shower immediately.
6. **DO NOT** switch the shower on if the case appears to be damaged or incorrectly fitted. Isolate the electrical supply to the shower immediately.
7. Switch off the appliance at electrical isolating switch when not in use. This is for safety and is recommended with all electrical appliances.
8. **DO NOT** connect the outlet of the shower to any tap, control valve, trigger handset or showerhead other than those specified for use with this shower. Only Kohler Mira recommended accessories should be used.
9. Only Kohler Mira recommended shower hoses and showerheads should be used for Airboost products.
10. Always check the water temperature before entering the shower. Sunburn or skin conditions can increase your sensitivity to hot water. Make sure that you set the shower to a cooler temperature.
11. **DO NOT** operate the temperature control rapidly, allow 10 – 15 seconds for the temperature to stabilise before use.
12. Care is required if the shower is turned off and back on during showering as this may result in unstable temperature. Ensure temperature has stabilised before re-using shower.
13. The showerhead must be de-scaled regularly, refer to the user maintenance section towards the rear of this guide for details.
14. The shower hose must be checked regularly and replaced if damaged, refer to the user maintenance section towards the rear of this guide for details.
15. The shower must be operated and maintained in accordance with the requirements of this guide.
16. If any of the following conditions occur, isolate the electricity and water supplies and contact Kohler Mira Customer Service.
  - If the case is damaged or the cover is not correctly fitted and water has entered the shower case.
  - If the shower begins to make an odd noise, smell or smoke.
  - If the shower shows signs of a distinct change in performance indicating a need for maintenance.

# OPERATION

Read the section “**IMPORTANT SAFETY INFORMATION**” first.

1



Switch on the electrical supply.

2

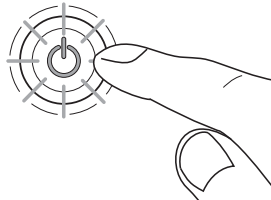

Push START/STOP button. Light in the button illuminates.

3

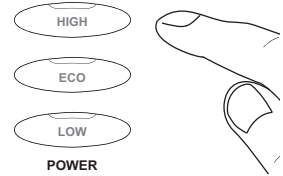

Push power button for the desired output. The button illuminates.

4

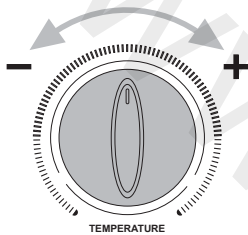

Adjust temperature as required.

5

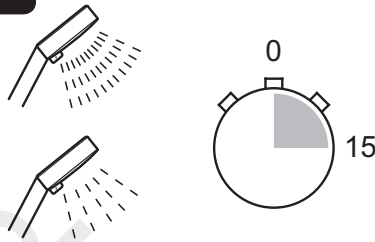

Allow 10 - 15 secs for any temperature adjustments to stabilise and reach the showerhead.

6

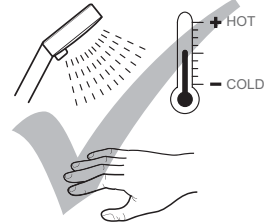

Check water temperature before entering shower.

7

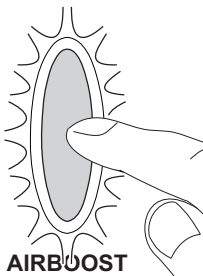

Push Airboost button if required. The Airboost button will illuminate and briefly flash.

8

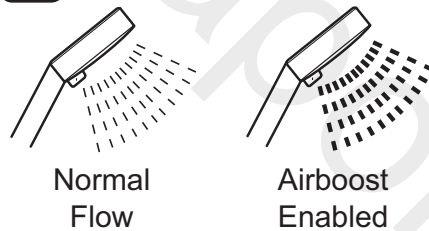

Aerated water flows from the Showerhead

9

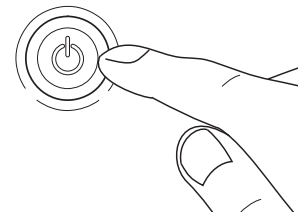

Push START/STOP button. Light in the button goes out and shower continues to run for a few seconds.

10



Switch off the electrical supply.

11

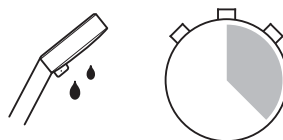

A small amount of water may continue to drain over a few minutes.

**WARNING!** Turning the shower off and back on during showering may result in unstable temperatures at the showerhead. Always ensure the temperature has stabilised before re-using the shower.

**Note!** When the shower is **not** running or the STOP button has been pressed, the three white power button lights will dim after a short time, indicating the shower has entered a "stand-by" mode. A slight hissing sound may also be heard from the shower during operation. High mains water pressure and high shower temperatures will affect the tone. This is quite normal in use.

## The Effect of Seasonal Changes

Incoming mains water temperature is not constant throughout the seasons of the year i.e. cooler during the winter, warmer during the summer, these changes can affect the outlet temperature of the shower, therefore the shower temperature may need to be increased or decreased to maintain the desired showering temperature.

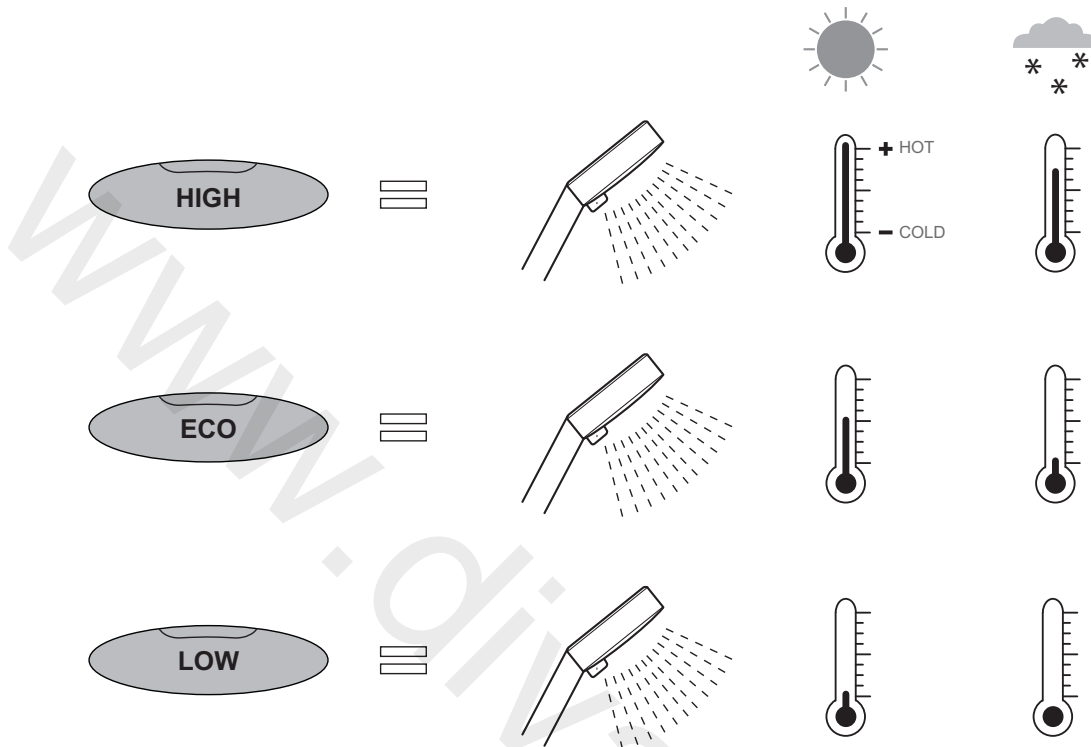

For a winter warm shower select HIGH  
 For a summer warm shower select ECO/HIGH  
 For a cold shower select LOW  
 Adjust the temperature as required  
 The flow rate will adjust automatically

## The Effect of Other Water Devices

Example of how shower temperature stabilises due to pressure changes.

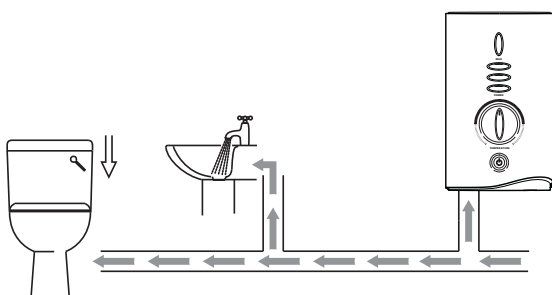

Selected Showering Temperature

+

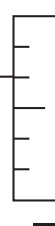

Showering temperature will stabilise to within 6°C band if other outlets are opened whilst showering, providing the minimum pressure does not fall below:

70 kPa (0.7 bar) - 9 kW  
 100 kPa (1.0 bar) - 10.8 kW

Water inlet pressure fluctuations due to other draw offs (e.g. flushing toilet) will cause the showering temperature to increase.

# USER MAINTENANCE

In the event of a malfunction of the shower, a fault finding table is provided in this guide detailing possible causes and remedies that may be carried out by non-qualified personnel.

## WARNING - TO REDUCE THE RISK OF FIRE, ELECTRIC SHOCK, INJURY OR PRODUCT DAMAGE:

- There are no user serviceable parts inside the shower. Only qualified, competent personnel should remove the front cover, mains connections are exposed when the cover is removed.
- Switch the shower off at the isolator switch before performing any user maintenance or before cleaning the shower.
- **DO NOT** allow young children to perform user maintenance including cleaning of the shower.
- **DO NOT** use the showerhead to clean the shower.
- If the shower is not to be used for a long period, the electrical supply and water supply to the shower should be isolated. If the shower or pipework is at risk of freezing during this period a qualified, competent person should drain them of water.

## Cleaning

Many household cleaners contain abrasives and chemical substances, and should not be used for cleaning plated or plastic fittings. These finishes should be cleaned with a mild washing up detergent or soap solution, and then wiped dry using a soft cloth.

## De-scaling the Showerhead

**Important!** Keeping the showerhead clean and free from limescale will ensure that your shower and showerhead continue to perform to their maximum. A blocked showerhead can restrict the flow rate and may cause damage to your shower

## Inspecting the Shower Hose and Diffuser

**Important!** The shower hose should be inspected periodically for damage or internal collapse, internal collapse can restrict the flow rate from the showerhead and may cause damage to the shower.

1. Unscrew the shower hose from the shower then pull the Air Pipe Adaptor from the shower outlet.
2. Unscrew the shower hose from the Showerhead, pull out the Air pipe Diffuser. Ensure the diffuser holes are free from scale, clean if necessary.
3. Pull the Air Pipe Adaptor from the Air Pipe then withdraw the Air Pipe from the hose.
4. Inspect and replace the hose if necessary.
5. Reassemble parts in reverse order.

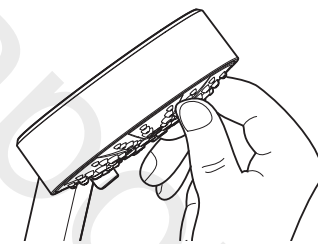

Use your thumb or a soft cloth to wipe any limescale from the soft nozzles

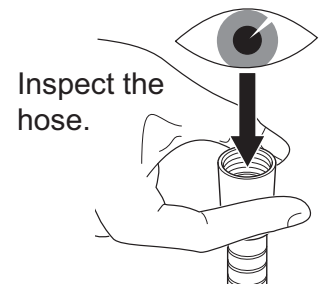
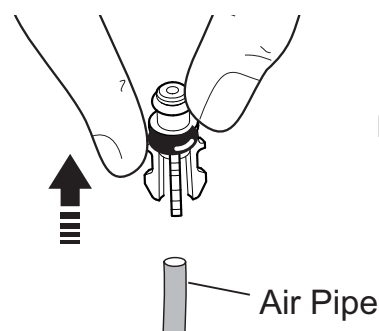
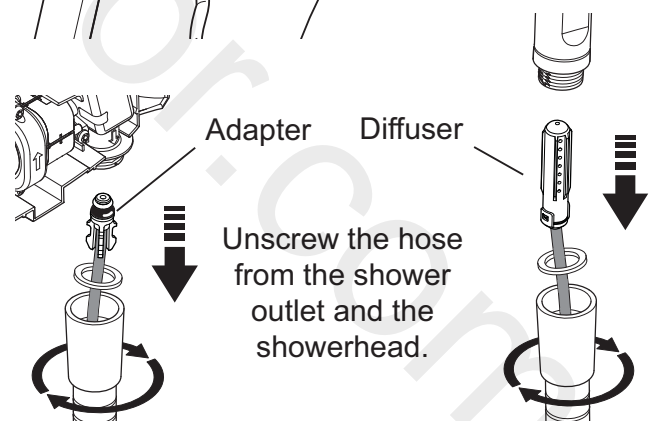

# FAULT DIAGNOSIS

If the malfunction has not been detailed in the fault finding table or it was not possible to correct the malfunction, professional assistance may be required. A more detailed fault finding process is included in the Installation Guide for use by qualified, competent personnel only.

Symptom	Start/Stop Light is ON or OFF	Power Control Position	Possible Cause	Possible Remedy
Shower fails to operate.	OFF	ANY	Isolator switch in the off position.  Fuse blown or MCB/RCD tripped, indicating possible electrical fault.	Switch on electrical supply via the pullcord or wall mounted switch.  Renew the fuse or reset the MCB/RCD. If fault persists, contact your installer.
Shower cycles from hot to cold.	ON	ECO/ HIGH	Showerhead blocked.  Water pressure below minimum required for shower operation.  Temperature control or power control setting too high.	Remove and clean.  Make sure incoming mains water stopcock and/or shower isolating valve is fully turned on.  Turn the power control to Eco or turn the temperature control until a cooler temperature is achieved.
Unable to select a cool enough shower.	ON	ANY	Due to the rise in mains water supply temperature, the heater setting may be too high	Turn the power control to Eco or turn the temperature control until a cooler temperature is achieved.
Low or no flow.	ON	ANY	Showerhead blocked.  Hose kinked or blocked  Other outlets (e.g. toilet, garden hose, washing machine, etc.) drawing water while the shower is being used	Remove and descale Showerhead  Check hose and replace if necessary, see section - <b>'USER MAINTENANCE'</b> .  Turn off other appliances whilst shower is in use.
Operation of Temperature Control has little or no effect on water temperature	ON	ECO/ HIGH	Showerhead blocked.  Hose kinked or blocked	Remove and descale Showerhead  Check hose and replace if necessary, see section - <b>'USER MAINTENANCE'</b> .

# CUSTOMER SERVICE

## Guarantee

Your product has the benefit of our manufacturer's guarantee which starts from the date of purchase.

To activate this guarantee, please return your completed registration card, visit our website or free phone 0800 0731248 within 30 days of purchase (UK only).

Within the guarantee period we will resolve defects in materials or workmanship, free of charge, by repairing or replacing parts or product as we may choose.

**This guarantee is in addition to your statutory rights and is subject to the following conditions:**

- The guarantee applies solely to the original installation under normal use and to the original purchaser only. The product must be installed and maintained in accordance with the instructions given in this user guide.
- Servicing must only be undertaken by us or our appointed representative. **Note!** if a service visit is required the product must be fully installed and connected to services.
- Repair under this guarantee does not extend the original expiry date. The guarantee on any replacement parts or product ends at the original expiry date.
- For shower fittings or consumable items we reserve the right to supply replacement parts only.

**The guarantee does not cover:**

- Call out charges for non product faults (such as damage or performance issues arising from incorrect installation, improper use, lack of maintenance, build up of limescale, frost damage, corrosion, system debris or blocked filters) or where no fault has been found with the product.
- Water or electrical supply, waste and isolation issues.
- Compensation for loss of use of the product or consequential loss of any kind.
- Damage or defects caused if the product is repaired or modified by persons not authorised by us or our appointed representative.
- Routine maintenance or replacement parts to comply with the requirements of the TMV 2 or TMV 3 healthcare schemes.
- Accidental or wilful damage.
- Products purchased ex-showroom display.

## What to do if something goes wrong

If your product does not function correctly when you first use it, contact your installer to check that it is installed and commissioned in accordance with the instructions in this manual.

If this does not resolve the issue, contact our Customer Services Team who will offer you or your installer help and advice.

If you experience problems, check in this manual to see if simple home maintenance is required. If you require further assistance call our Customer Services Team.

## Extended Guarantees

A selection of protection plans are available that enable you to cover repair bills for the life of your policy (excludes Eire). Ring 01922 471763 for more details.

## Helpdesk Service

Our Customer Services Team is comprehensively trained and can offer help and advice, spare parts, accessories or a service visit.

We will need you to have your model name or number, power rating (if applicable) and date of purchase. As part of our quality and training programme calls may be recorded or monitored.

## Mira Showers Website ([www.mirashowers.co.uk](http://www.mirashowers.co.uk))

From our website you can register your guarantee, download additional user guides, diagnose faults, purchase our full range of accessories and popular spares, refer to our FAQ's and request a service visit.

## Spares and Accessories

We maintain extensive stocks of genuine spares and accessories and aim to provide support throughout the product's expected life.

Payment can be made by phone at time of order using most major Credit or Debit cards and we aim to despatch orders within 2 working days. Items purchased from us are guaranteed for 12 months from date of purchase. For safety reasons spares exposed to mains voltages should only be fitted by competent persons.

**Returns** – items can be returned within one month of date of purchase, providing that they are in good condition and the packaging is unopened. If you wish to return any items please notify us in writing within seven days of receipt.

## Service / Repairs

We have a nationwide team of Service Technicians can carry out service or repair work to your product within the guarantee period and beyond. You have the assurance of a fully trained Technician, genuine spare parts and a 12 month guarantee on any chargeable work done.

Payment should be made directly to the Service Technician who will accept most major Credit or Debit cards.

## To Contact Us

### UK

**Telephone: 0844 571 5000**

E-mail - Visit [www.mirashowers.co.uk/contactus](http://www.mirashowers.co.uk/contactus)

Fax: 01242 282595

By Post: Mira Customer Services Dept, Cromwell Road, Cheltenham, Gloucestershire, GL52 5EP

### Eire

**Telephone: 01 459 1344**

E-mail: [sales@modernplant.ie](mailto:sales@modernplant.ie)

Fax: Dublin 01 459 2329

By Post: Modern Plant Ltd (Dublin),

Otter House, Naas Road, Clondalkin, Dublin 22

Mira is a registered trade mark of Kohler Mira Limited.

The company reserves the right to alter product specifications without notice.

[www.mirashowers.co.uk](http://www.mirashowers.co.uk)

*Showering perfection*

**mira**  
SHOWERS