

AXCES
by VADO

This instruction booklet covers model:
AX-BOK-149T-CP

BOKX

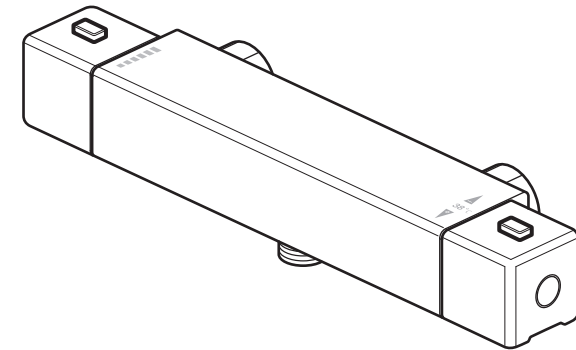

INSTALLATION /
USER MANUAL

Important - please read

Please read these instructions carefully before starting installation and keep for future reference.

Remove all packaging and check the product for missing parts or damage before starting installation.

Any alterations made to this product and fittings may infringe water regulations and will invalidate the guarantee.

The installation must comply with all Local/National Water Supply Authority Regulations/Byelaws and Building and Plumbing Regulations.

To be installed in accordance with BS EN806.

We strongly recommend that you use a qualified and registered plumber.

General installation

This fitting is a mixing device and therefore water supplies should be reasonably balanced.

When installed, the fitting must comply with the requirements of the Water Supply (Water Fittings) Regulations 1999 and Scottish Byelaws 2004.

For further information, contact the Water Regulations department of your local water supplier (see the WRAS website www.wras.co.uk for details) or the Water Regulations Advisory Scheme by email (info@wras.co.uk) or telephone: 01495848454.

Before making any inlet pipe connections, all supply pipes MUST be thoroughly flushed to remove debris. Failure to do so could result in damage or low flow from the mixer unit. Water Supply (Water Fittings) Regulations 1999 Schedule 2 Section 13.

The fitting of isolating valves to the inlet feeds is advised for ease of maintenance.

Please take great care when installing this mixer not to damage its surface.

Please note if installing in an enclosed environment, access should be left for servicing and maintenance. No costs relating to inadequate access can be accepted.

Operating Specifications

Operating Pressure

Minimum operating pressure **1 bar**

Maximum operating pressure **5 bar**

Contents of Packaging

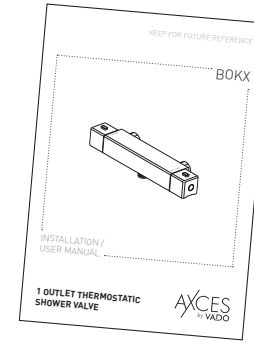

Installation guide &
User manual

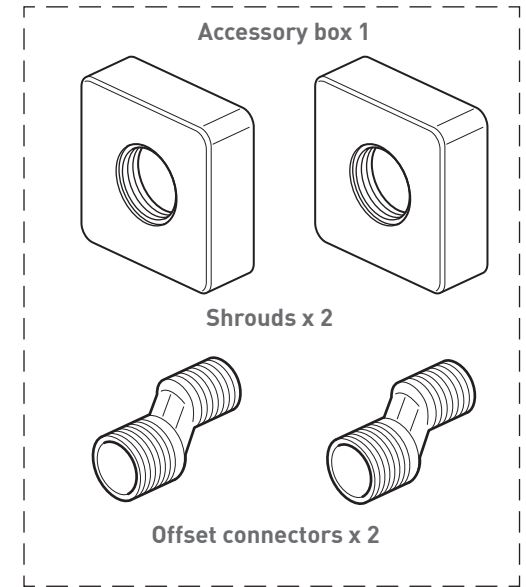

Accessory box 1

Shrouds x 2

Offset connectors x 2

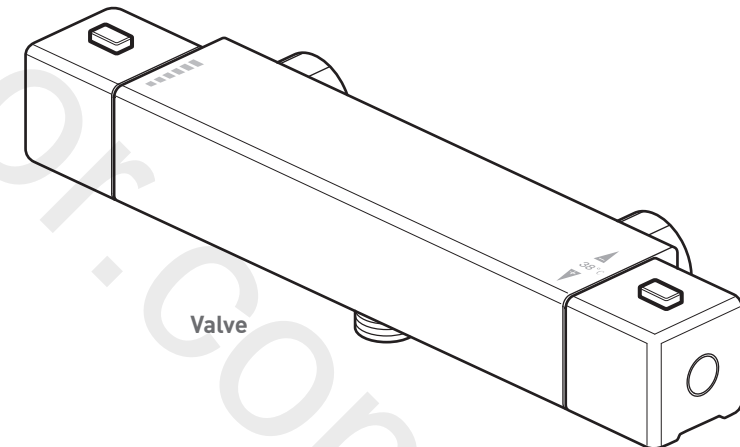

Valve

Dimensions

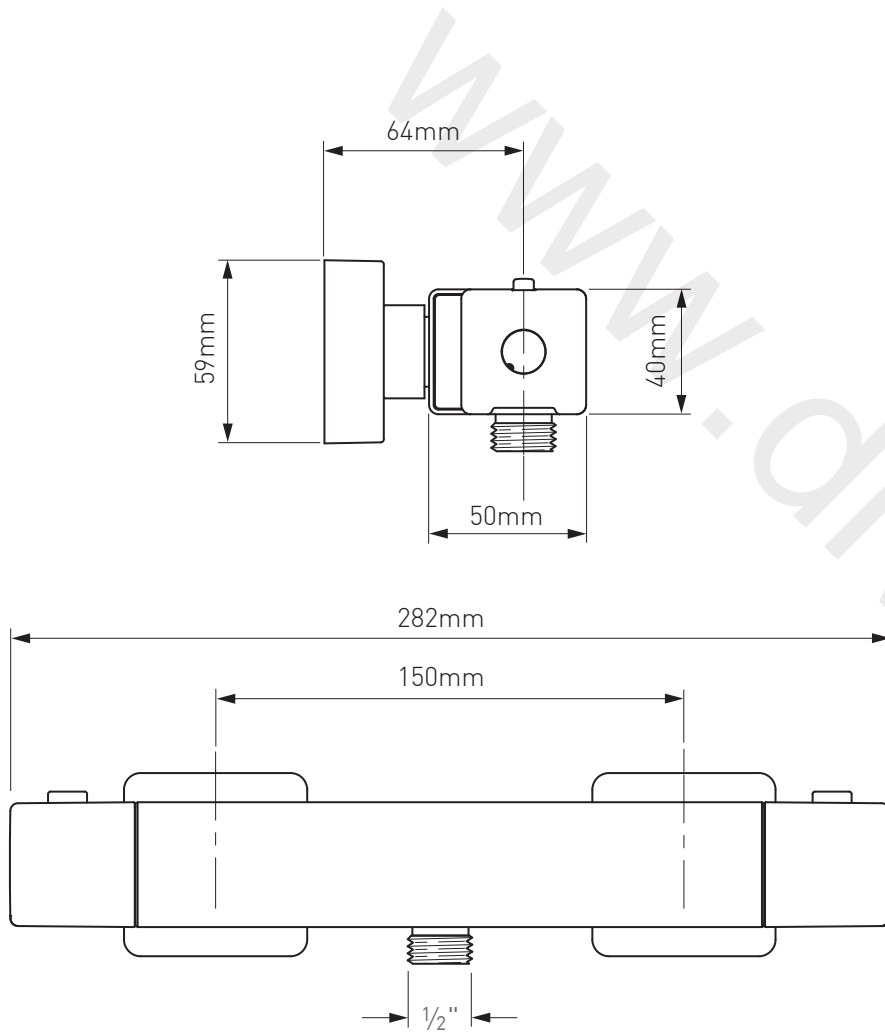

Installation

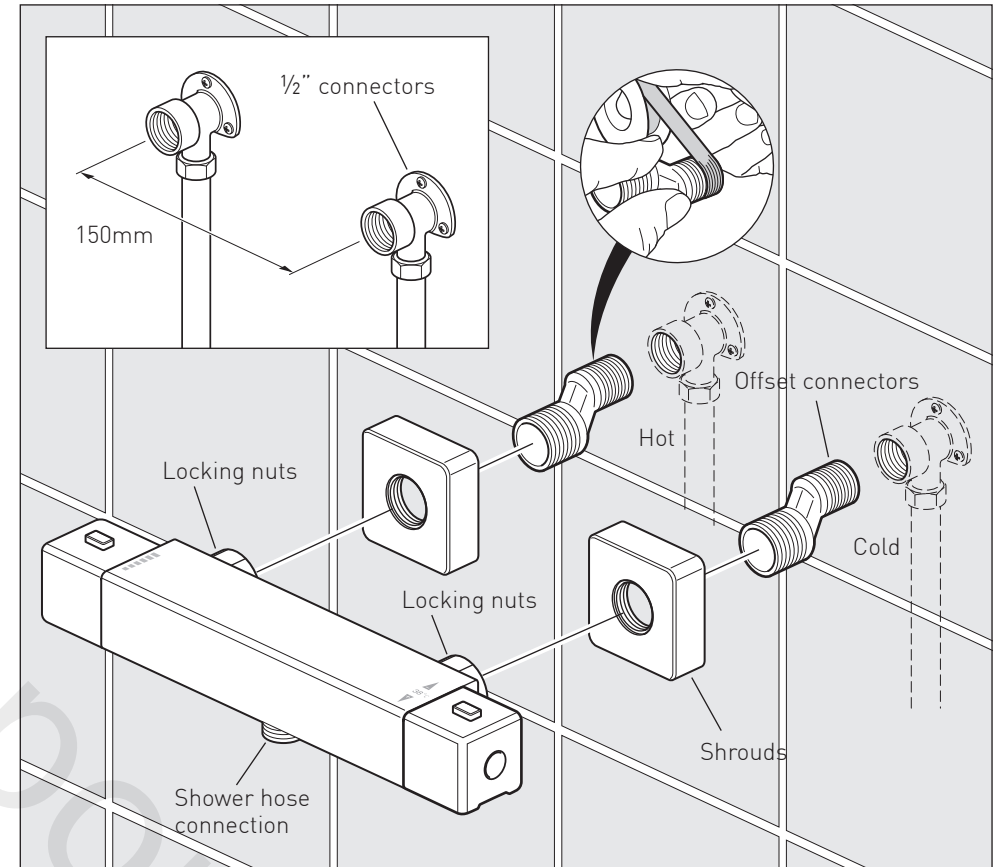

Before installing your new mixer, flush through the pipe work to ensure removal of debris, turn off the water supply.

Prepare the wall with 2 flush 1/2" connectors at 150mm centres. Connect the water supply to the inlet pipes. The hot water should be connected to the left hand connector and cold to the right.

Note: The valve must be connected to rigid pipe work for support.

Using PTFE tape screw the offset connectors to the wall fittings followed by the shrouds.

Screw the locking nuts of the valve onto the connectors, some adjustment can be made to the offset connectors to align the centres and level up the valve.

Attach the shower hose to the outlet at the bottom of the valve.

Operation

Turning the handle away from the user will start the flow of water.

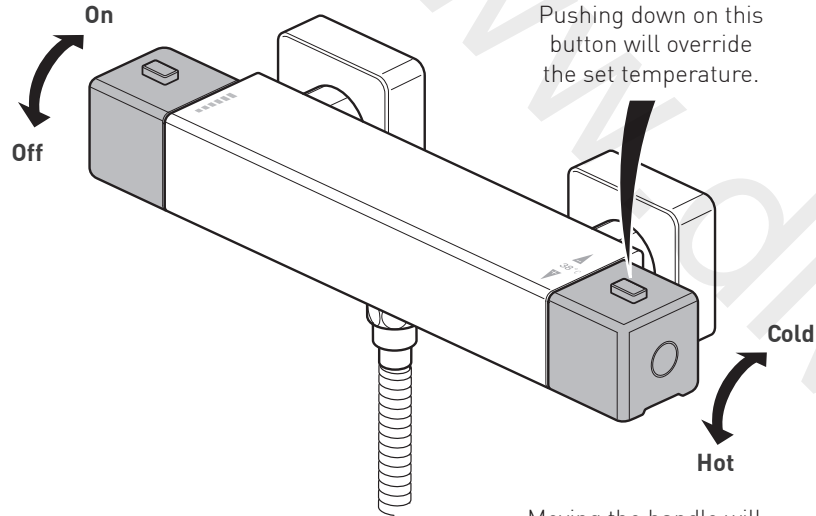

Moving the handle will increase/decrease the water temperature.

Cleaning instructions

The electroplating on this product is finished to the highest standard. Due care needs to be taken to ensure the appearance is retained.

We recommend cleaning all products with a soft damp cloth ONLY and advise strongly against the use of all aggressive/corrosive cleaning products i.e. powders and liquids. If these instructions are not followed, this may invalidate your guarantee in the event of a problem occurring.

Commissioning

The valve has been factory set under balanced pressures and hot water supply at 65°C. When your specific operating conditions are significantly different from the above, the temperature of the water may vary from the setting.

When the difference is too great, you can adjust the calibration of the valve to suit individual requirements of the installation:

1. Check the temperature of the water being delivered from the outlet with a thermometer.

Note: temperature readings should be taken at normal flow rate after allowing for the system to stabilise.

2. If the temperature is not 38°C (When the 38° is aligned with the override button) proceed to reset the calibration as follows.

Remove the handle: Prise out the cover, remove the screw and pull off the handle and spacer ring.

Ensure the step on the stop ring is located at 12 o'clock.

Do not remove the plastic stop ring. Turn the spline of the thermostatic valve clockwise to decrease the temperature and anti-clockwise to increase the temperature until 38°C is achieved at outlet.

Note: the sensing part of the thermometer probe must be fully submerged in the water that is to be tested.

Replace the spacer and handle making sure that the pin is against the step (see detail).

Once the handle has been attached ensure the temperature does not exceed 46°C when turned entirely anti-clockwise.

Your valve setting is now commissioned.

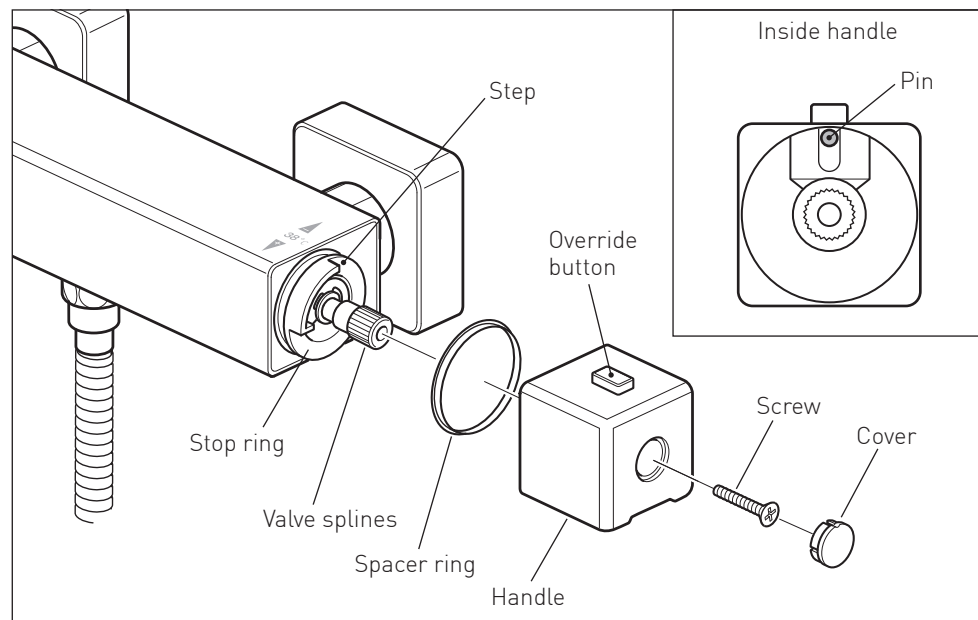

Maintenance

We advise that the below is carried out annually as failure to do so may result in invalidation of warranty.

Isolating the thermostatic valve

IMPORTANT: Please see the below procedure for isolating the thermostatic valve.

1. Isolate the incoming hot and cold water to the valve.
2. Turn shower valve on (left handle) to check isolation, please ensure that your body/hands are not under the flow of water as there is a potential for delivery of hot water.
3. Remove temperature control handle and temperature stop ring (essential).
4. With shower in the on position, replace temperature handle on thermostatic Valve (ensure temp stop has been removed).
5. Turn temp handle fully anti clockwise until stop point is reached and can be turned no further, please ensure that your body/hands are not under the flow of water as there is potential for delivery of hot water if isolation has been unsuccessful.
6. Turn temperature handle fully clockwise until resistance is felt.
7. If there is no flow of water coming from the outlet during both points 5 and 6 isolation has been successful, you may now remove and maintain the cartridge.
8. If at any of the above point's water continues to flow please isolate at an alternative point within the system for both hot and cold and repeat points 2-8.

Filters

This thermostatic valve is fitted with a double filtering facility. Filters are fitted on the water inlets and on the thermostatic cartridge. Depending on the water quality, filters may become dirty, causing reduced flow and inefficient working of the valve.

Inlet filters

Check water has been isolated. Undo both locking nuts at the back of the valve and remove from the wall. Pull out the filter/washer, rinse in water to remove the dirt, and then soak them in vinegar or descaling agent.

Thermostatic cartridge

To clean the filters, you must first remove the cartridge from the housing.

Removing the Cartridge:

1. Check water has been isolated.
2. Remove the stop ring
3. Using a suitable spanner remove the thermostatic cartridge.
4. Clean filters by rinsing them under running water to remove any debris.
5. If there is limescale deposits then it is recommended to immerse the cartridge for a few minutes in 50% white vinegar + 50% hot water, brush the filters gently and then rinse under running water to clean all particles. If this is not effective, a replacement cartridge should be fitted.

Maintenance

6. Before reassembling the cartridge, clean its housing with a wet cloth and grease the 'O' rings using a suitable silicone grease.
7. Reassemble the cartridge into the body, then place the plastic stop ring onto the cartridge with the step at the 12 o'clock position.
8. Turn on the water supply.
9. Check the water temperature to ensure correct commissioning.
See page 8 of this guide for commissioning.
10. Ensure that the step on the stop ring is at 12 o'clock and replace the handle with the temperature override button also pointing at 12 o'clock being careful not to turn the spline of the valve.

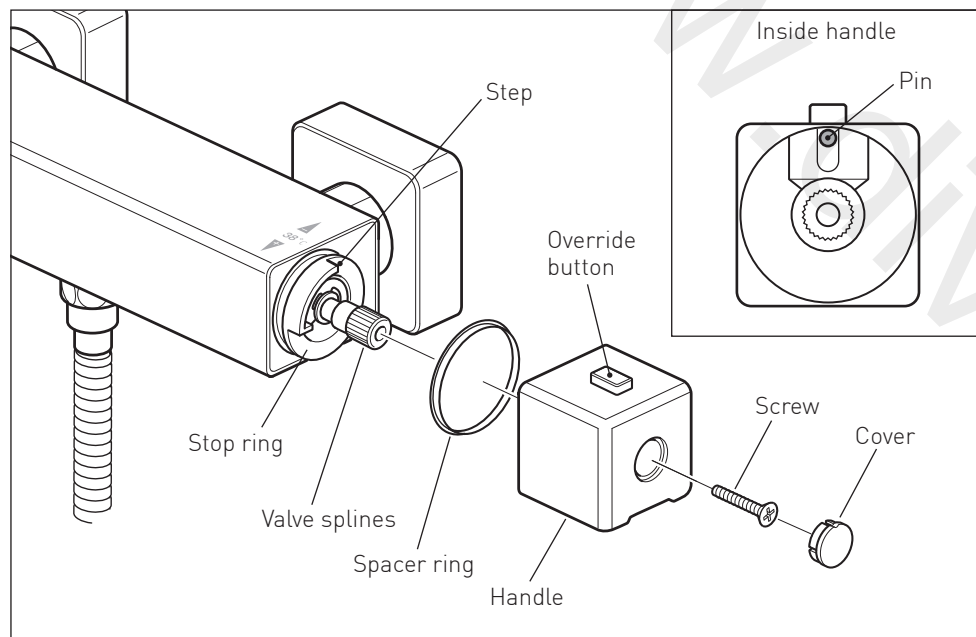

Guarantee

All AXCES by VADO products come with a 2 year guarantee as standard. Within this guarantee period VADO will provide replacement parts and any labour **[SEE NOTE 1, GUARANTEE CONDITIONS]** needed to complete the product repair.

This standard guarantee may be extended by registering your product to give a 10 year guarantee (2 years parts and labour plus 8 years on parts supply only.).

Operational components such as, but not limited to; thermostatic cartridges, diverters, headworks and flow control, waste mechanisms, shower hoses, O-rings and seals are guaranteed for 2 years parts and labour plus 3 years on parts supply only.

Guarantee Conditions

Our products are guaranteed against manufacturing defects from the date of purchase until the expiry of the relevant guarantee period shown above.

The guarantee is only valid if:

- The product has been installed, used and maintained in accordance with VADO's instructions and subjected to normal use only.
- The defect is not due to use of an unsuitable or inadequate water or power supply.
- The defect is not due to accident, misuse, neglect or incorrect/inappropriate repair (other than by VADO or VADO authorised agents) or damage caused by foreign objects or substances.
- The extended guarantee is only available if you have completed the Guarantee Registration Process. This can be done via the VADO website or via phone to our aftersales team. Registration must be completed within 6 months from date of purchase.

Under the extended guarantee period VADO will, at its option, offer to supply any replacement product (or component part) assessed to be defective **[SEE NOTE 2]**.

The guarantee (whether standard or extended) is non-transferable to any subsequent owner.

All claims under the guarantee should be notified in the first instance to our Aftersales department, contact details below, this must be done no later than the last day of the relevant guarantee period. All claims must be accompanied by proof of purchase (sales receipt or delivery note) from an official AXCES by VADO dealer.

The guarantee does not extend to any consequential loss or damage.

After repair or replacement, the relevant guarantee period will be calculated from the original date of purchase.

VADO operates a policy of continuous product development and therefore reserves the right to change the product, packaging and documentation specifications without notice.

NOTES:

[1] Labour via our engineer network is only available in the UK. Attendance by a VADO engineer or sub-contract engineer will be under our standard terms and conditions.

[2] VADO reserves the right to charge in advance for a product (or replacement part) pending collection and investigation (at VADO expense) to confirm a defect is due to a manufacturing issue. If a defect is found the charge will be refunded or cancelled.

This guarantee is in addition to and does not affect your statutory rights as a consumer.

Tel: 01934 745163

Email: aftersales@vado.com