

WARNING
 - Installation Performed By Qualified Personnel Only!
 - Clean Carefully The Water Pipes Before Installing The Tap
 and turn the boiler off and non return valves are not required.
 combination boilers are fitted it is only necessary to shut off the incoming mains
 hot and cold pipes as close as possible to the tap. These are not supplied. Where
 supplied from a tank and cold from the mains, non return valves are fitted on both
 These taps are double flow. Water bylaws require that where the hot water is
 Preparation and bylaw requirements
 5412:1996 where applicable.

All products are manufactured using materials tested and approved under the
 Water Bylaws Scheme and comply with requirements of British Standard
 5412:1996 where applicable.

Approvals
 All products are manufactured using materials tested and approved under the
 Water Bylaws Scheme and comply with requirements of British Standard
 5412:1996 where applicable.

claimable under the warranty.
 installation process, incorrect maintenance or misuse and as a result not be
 Defects notified after fitting may be regarded as damage resulting from the
 - On receipt of this product the chrome finish must be checked for blemishes.
 product may not correctly work or not work at all.
 - if the above mentioned conditions (see points 1,2,3,4) are not observed, the

1. Recommended working pressure:1 Bar
2. Maximum test pressure:5 Bar
3. Maximum hot water temperature : 80°C
4. We recommend installing filters to this product.
5. Warning:

Standard specifications
 The installation must comply with regulations of the Local Water Authority as
 contained in their bylaws. All of the taps in this range are double flow (the hot and
 cold water are separated) and should therefore be supplied with hot and cold
 water at balanced pressures, both from the tank or both from the mains (via a
 combination boiler for example). If the taps are not supplied at balanced pressures
 then the tap will not function correctly. It will also be necessary to fit non-return
 valves on both hot and cold feeds. It is very important that all pipe work is flushed
 thoroughly after installation to avoid damaging the ceramic disc.

Please read these instructions carefully and keep in a safe place for future
 reference.

INTRODUCTION

ATOLL WALL MOUNTED 2 HOLE BASIN SET

Art. AT121WNC

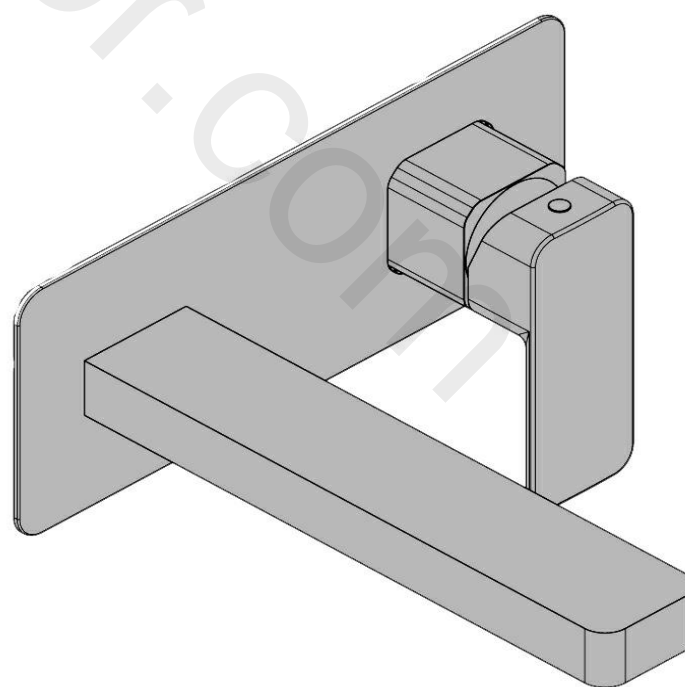

INSTALLATION INSTRUCTIONS

Note: dimensions in millimeter

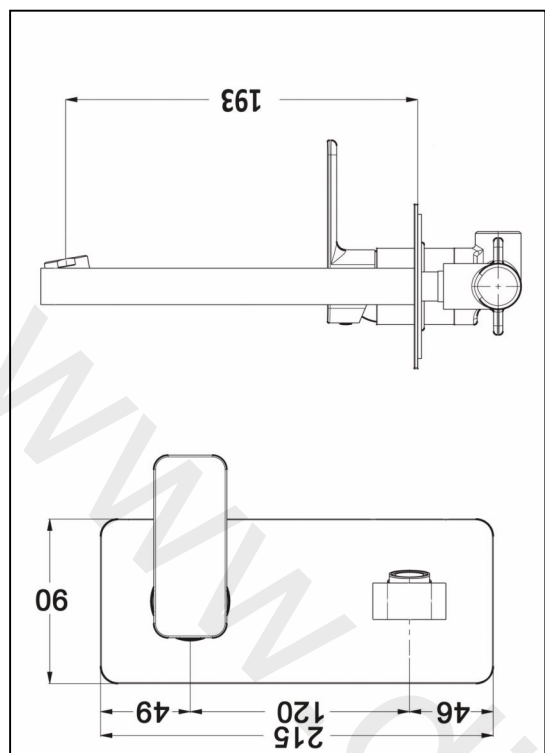
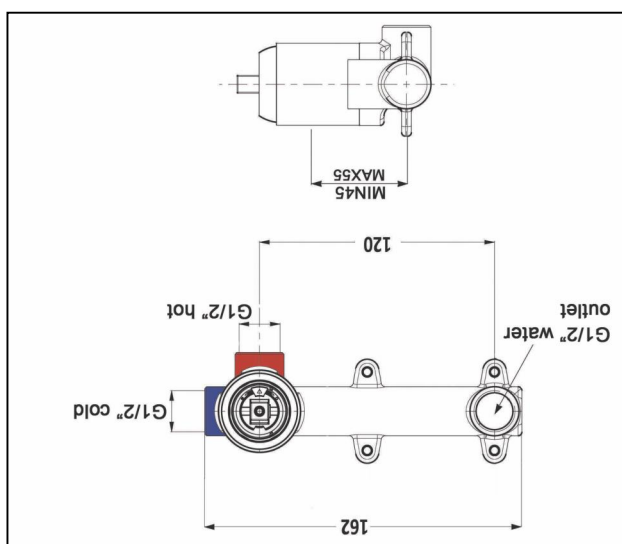

DIMENSIONS

This product should only be fitted by a qualified plumber to NVQ (National Vocational Qualification) or SNVQ (Scottish National Vocational Qualification) Level 3. Should the installation be completed by a non-qualified person then the guarantee may be considered invalid.

For a claim made under our warranty written certification of your installers credentials can be required. For further information or to find a qualified installer in your area please visit the Institute of Plumbers website - www.iphe.org.uk.

THE QUALIFICATIONS

At present, to be a plumber you need to follow the National Vocational Qualification (NVQ) route (Scottish National Vocational Qualification - SNVQ - in Scotland). These qualifications are made up of theory and practical work in the classroom/purpose built training facility and work based experience with a working plumber. Colleges should help students find a work placement, although many students organise it themselves.

The S/NVQ qualification works in levels. All recently qualified plumbers should hold S/NVQ Level 2 as basic with Level 3 as the preferred level. Level 2 will give you the foundation you need for a career in plumbing and teach you domestic plumbing to a satisfactory level. Level 3 is more comprehensive and deals with domestic, commercial and industrial plumbing along with aspects such as gas - if you want to one day set up your own business, this is the level to reach. The Institute of Plumbing and Heating Engineering, and the industry as a whole recommends that all plumbers reach a minimum of Level 3.

Reaching Level 3 has other advantages. The Institute runs a Master Plumber Certificate, which only those attaining Level 3 or equivalent can reach as long as they have the relevant experience as well. Those with S/NVQ Level 3 can (once in membership with the Institute for five years as a Member MIPHE) gain Engineering Technician EngTech status with the Engineering Council (UK).

For any further information please contact Crosswater on: **0845 873 8840**
 Or visit our web-site at www.crosswater.co.uk
 The manufacturer reserves the right to make technical modifications without prior notice.



INSTALLATION

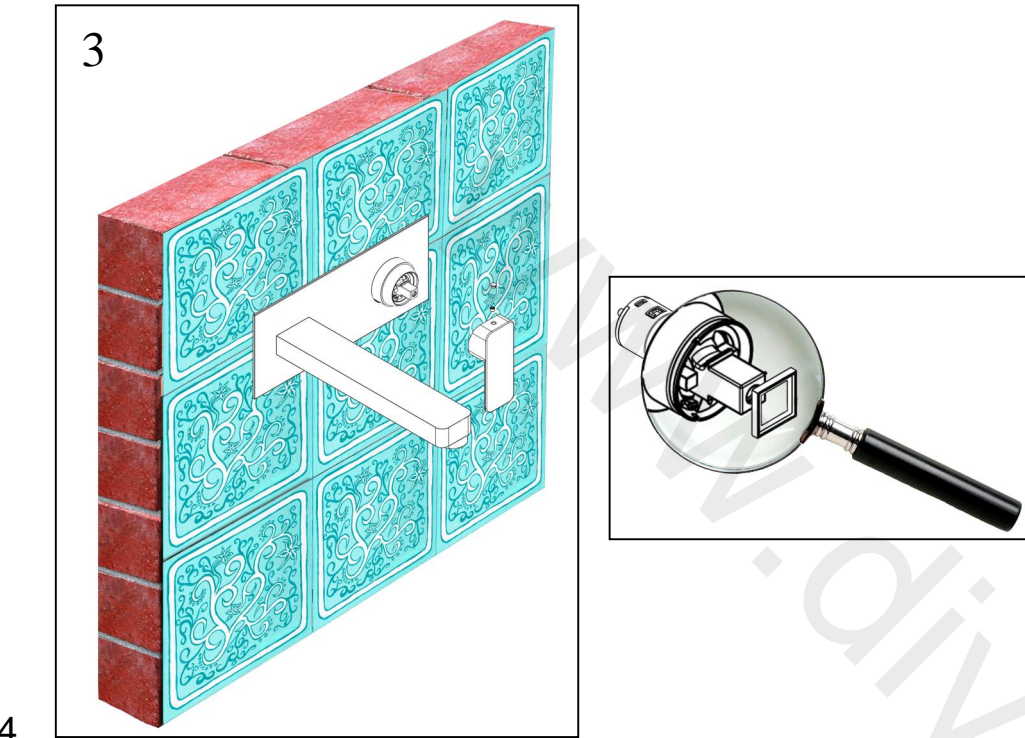
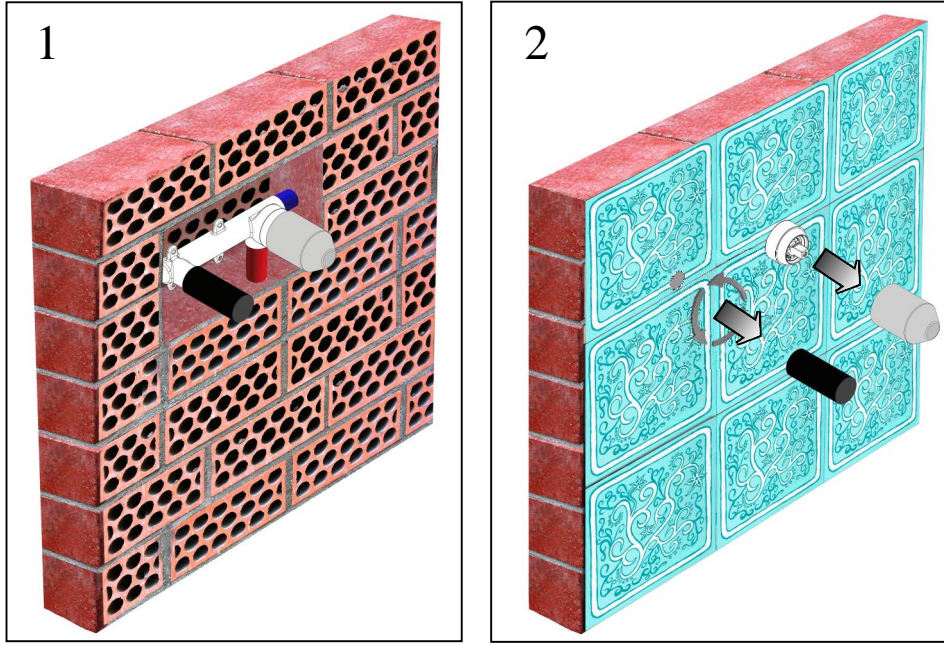

INSTALLATION



First shut off your water heating system then, with the mains stop cock closed, open the lowest hot and cold taps in the house and allow to run until the cold storage tank and pipes are empty (the hot water storage cylinder airways remains full). Where combination boilers are fitted it is only necessary to turn off the boiler and shut off the incoming mains. Fitting isolating valves to the inlet feeds is recommended for ease of maintenance. Flush the piping with plenty of water prior to installation.

INSTALLATION

~ Decide on a suitable position for the Mixer where all users can operate; determine the route for the incoming cold-hot supply pipe work. Mark an opening sufficient to accommodate the mixer body, for dimensions refer to template (see pag. 3).

~ Install the hot and cold supply with 1/2" pipe connection to the tap body and ensure precise horiz/vertical alignment with a spirit level.

~ Don't remove plastic cover (2) on the built-in tap, until the wall is completely finished; when tiles have set, remove the plastic cover.

~ Installation spout: screw and seal the fitting (A) in the water outlet connection on the wall, insert the concealing plate, smooth side against the wall, insert the spout and tighten it with the grub screw (B).

~ Set the handle in position and secure it with the grub screw, and relace the cap.

INSTALLATION SPOUT

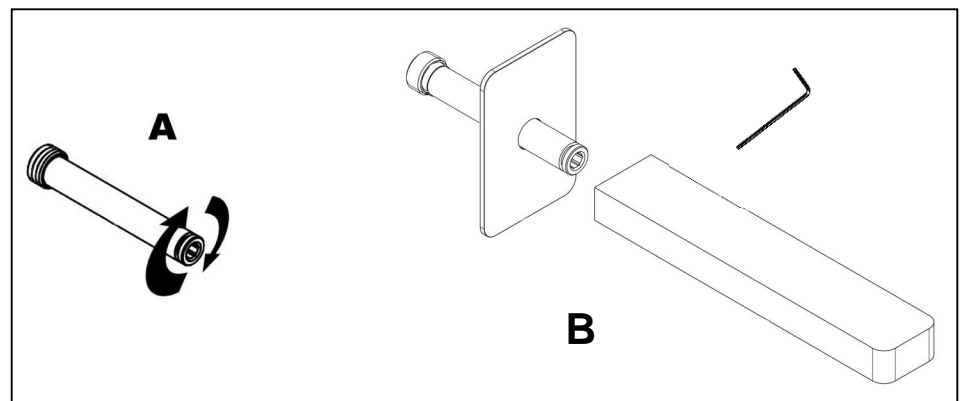

MAINTENANCE

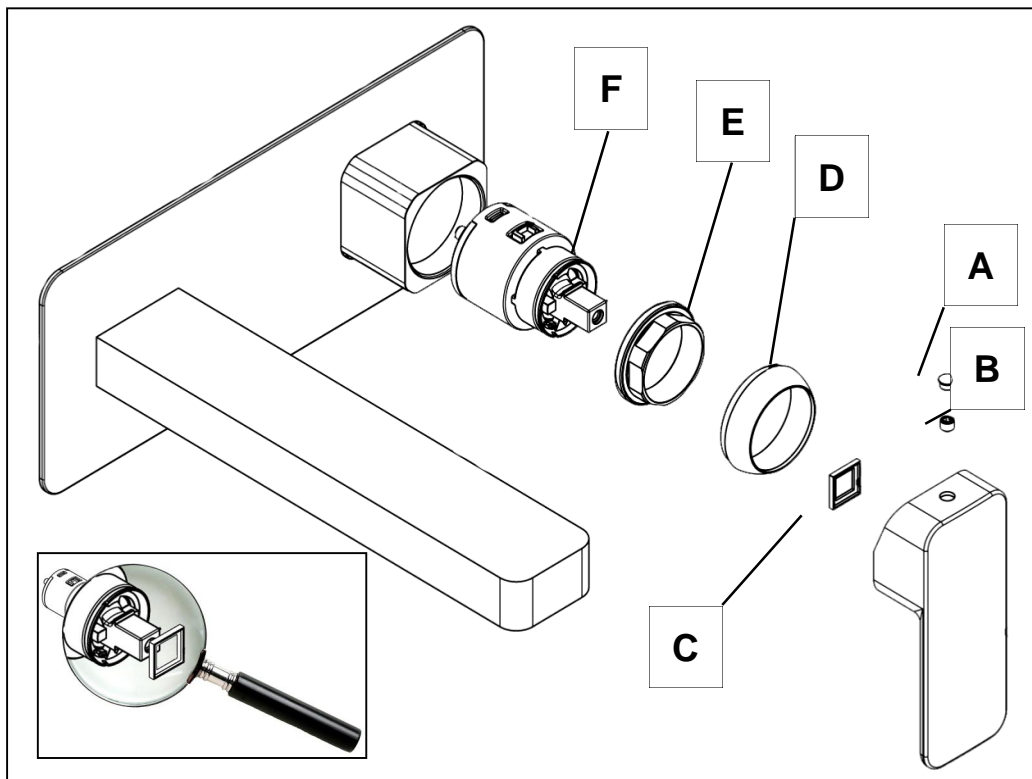

CLEANING - REPLACE THE CARTRIDGE

In the event of any problems, servicing is straight forward.

First shut off the water supply to the tap. Pull out the cap (A) from the handle and with an allen key 2,5mm loosen the grub screw (B) in handle, but do not remove it. Take off the handle, unscrew insert (C) and the cartridge cover (D), carefully using a correct size spanner unscrew the retaining nut (E) and remove the cartridge (F). Replace or wash the cartridge with clean running water and make sure that any trapped debris have been removed. Dry and lightly grease the seals (only use silicone grease) insert the cartridge, screw retaining nut, cartridge cover followed by the insert and handle.

CAUTION: Retaining nut (E), must be screw with a torque of 10/11Nm, in case of incorrect tighten, the mixer can be damaged.

CLEANING

The chrome plate we use on our taps is very durable, nevertheless care should be taken when cleaning them. They should be cleaned only with warm soapy water followed by rinsing with clean water and drying with a soft cloth. All finishes are vulnerable to acid attack and some strong substances such as household cleaners, disinfectants, denture cleaners, hair dyes, wine making and photographic chemicals can cause the surface to go black or peel.

MIXER NOZZLE

All the taps are fitted with a flow straightener. If the water supply is not smooth, remove the aerator and clean. Unscrew the nozzle from the spout mixer, taking care not to lose the washer. Wash the nozzle with clean running water and make sure that any trapped debris is removed.

To remove limescale we suggest to putting the nozzle in vinegar. To replace insert the washer, and screw the nozzle, tightening well.