**AT0005RC****BUILT-IN BATH/SHOWER MIXER****INTRODUCTION**

Please read these instructions carefully and keep in a safe place for future reference.

General Installation Requirements

The installation must comply with regulations of the Local Water Authority as contained in their bylaws. All of the taps in this range are double flow (the hot and cold water are separated) and should therefore be supplied with hot and cold water at balanced pressures, both from the tank or both from the mains (via a combination boiler for example). If the taps are not supplied at balanced pressures then the tap will not function correctly. It will also be necessary to fit non-return valves on both hot and cold feeds. It is very important that all pipe work is flushed thoroughly after installation to avoid damaging the ceramic disc.

Standard specifications

1. Recommended working pressure:1 Bar
2. Maximum test pressure:5 Bar
3. Maximum hot water temperature : 80°C
4. We recommend installing filters to this product.
5. Warning: if the above mentioned conditions (see points 1,2,3,4) are not observed, the product may not correctly work or not work at all.

- On receipt of this product the chrome finish must be checked for blemishes. Defects notified after fitting may be regarded as damage resulting from the installation process, incorrect maintenance or misuse and as a result not be claimable under the warranty.

Approvals

All products are manufactured using materials tested and approved under the Water Bylaws Scheme and comply with requirements of British Standard 5412:1996 where applicable.

Preparation and bylaw requirements

These taps are double flow. Water bylaws require that where the hot water is supplied from a tank and cold from the mains, non return valves are fitted on both hot and cold pipes as dose as possible to the tap. These are not supplied. Where combination boilers are fitted it is only necessary to shut off the incoming mains and turn the boiler off and non return valves are not required.

WARNING

- Installation Performed By Qualified Personnel Only !
- Clean Carefully The Water Pipes Before Installing The Tap.

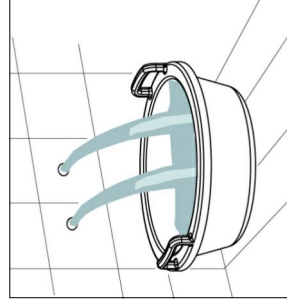
**THE QUALIFICATIONS**

At present, to be a plumber you need to follow the National Vocational Qualification (NVQ) route (Scottish National Vocational Qualification - SNVQ - in Scotland). These qualifications are made up of theory and practical work in the classroom/purpose built training facility and work based experience with a working plumber. Colleges should help students find a work placement, although many students organise it themselves.

The S/NVQ qualification works in levels. All recently qualified plumbers should hold S/NVQ Level 2 as basic with Level 3 as the preferred level. Level 2 will give you the foundation you need for a career in plumbing and teach you domestic plumbing to a satisfactory level. Level 3 is more comprehensive and deals with domestic, commercial and industrial plumbing along with aspects such as gas - if you want to one day set up

your own business, this is the level to reach. The Institute of Plumbing and Heating Engineering, and the industry as a whole recommends that all plumbers reach a minimum of Level 3.

Reaching Level 3 has other advantages. The Institute runs a Master Plumber Certificate, which only those attaining Level 3 or equivalent can reach as long as they have the relevant experience as well. Those with S/NVQ Level 3 can (once in membership with the Institute for five years as a Member MIPHE) gain Engineering Technician EngTech status with the Engineering Council (UK).

This product should only be fitted by a qualified plumber to NVQ (National Vocational Qualification) or SNVQ (Scottish National Vocational Qualification) Level 3. Should the installation be completed by a non-qualified person then the guarantee may be considered invalid.
For a claim made under our warranty written certification of your installers credentials can be required. For further information or to find a qualified installer in your area please visit the Institute of Plumbers website - www.iphe.org.uk.

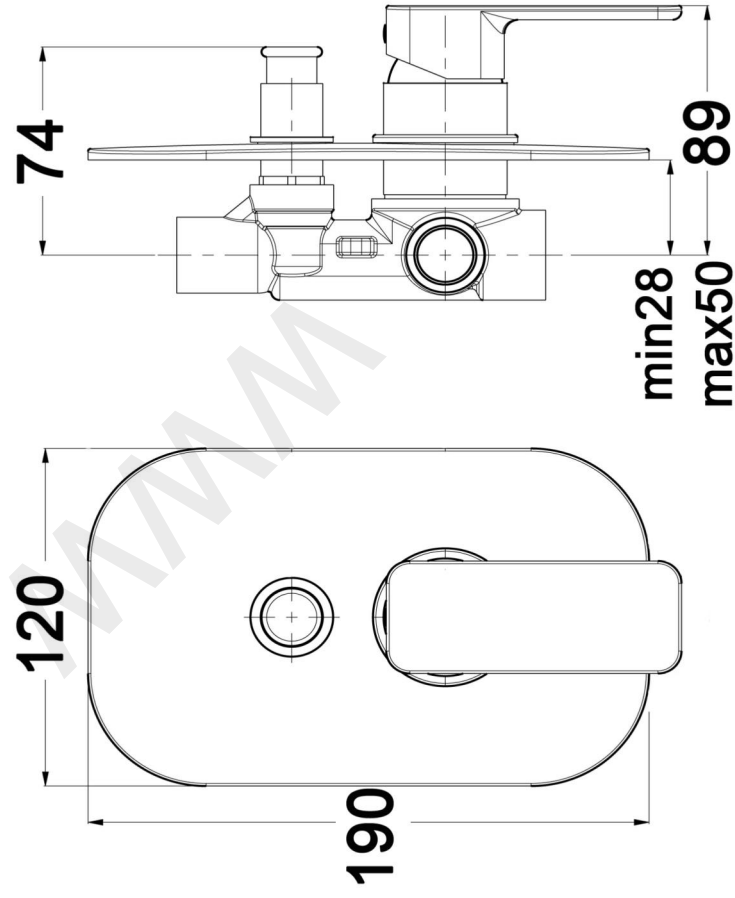
DIMENSIONS

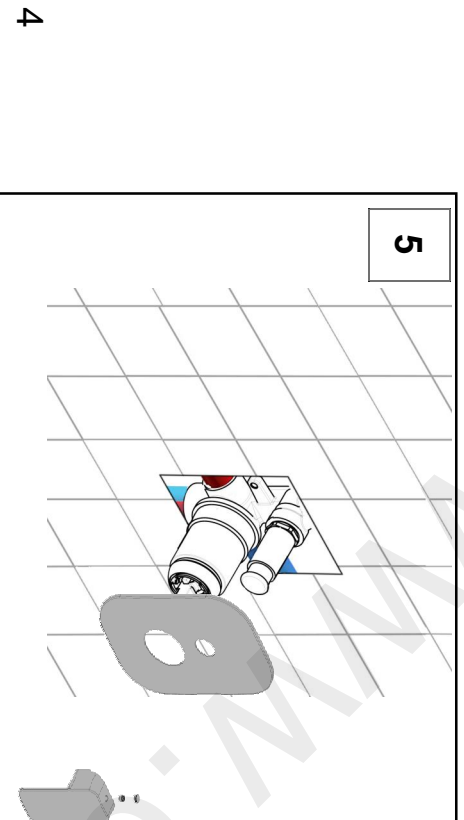
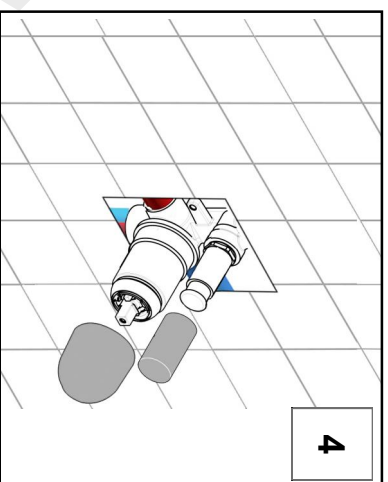
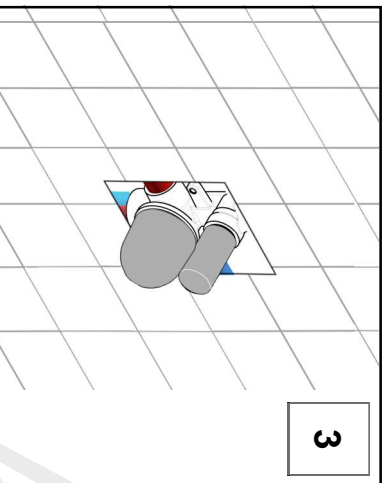
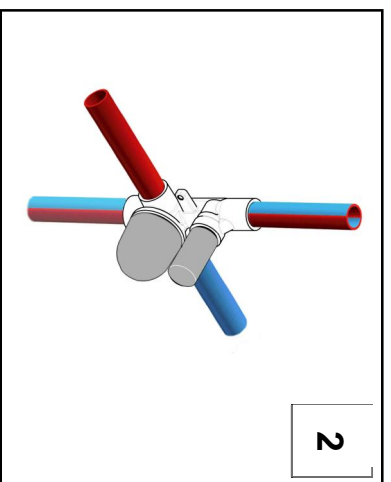
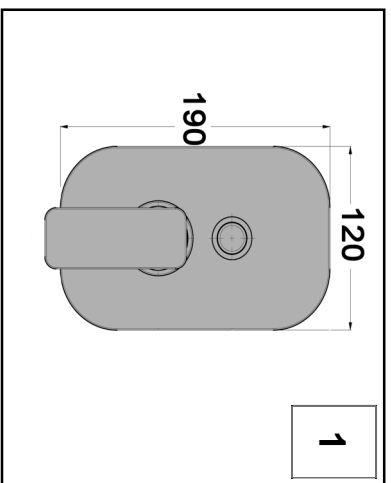

! First shut off your water heating system then, with you remains stop cock closed, open the Lowest hot and cold taps in the house and allow to run until the cold storage tank and pipes are empty (the hot water storage cylinder always remains full).
Where combination boilers are fitted it is only necessary to turn off the boiler and shut off the incoming mains. Fitting isolating valves to the inlet feeds is recommended for ease of maintenance.

“ Decide on a suitable position for the Mixer where all users can operate, determine the route for the incoming cold/hot supply pipe work and the outlet pipe work. Mark an opening sufficient to accommodate the Mixer body, whose dimension is to be smaller than concealing plate (1).
“ Install the Hot and Cold Supply (2). Use the upper outlet as second way out, connect the lower outlet to a spout/hand Shower.
“ Keep the Plastic Shroud (3) on the Built-in Mixer till the wall is not completed finished. When Tiles have set, remove the Shroud (4), insert the concealing plate (5) smooth side against the wall. Fit the Lever Assembly in place hand tighten it to secure the concealing plate.

MAINTENANCE

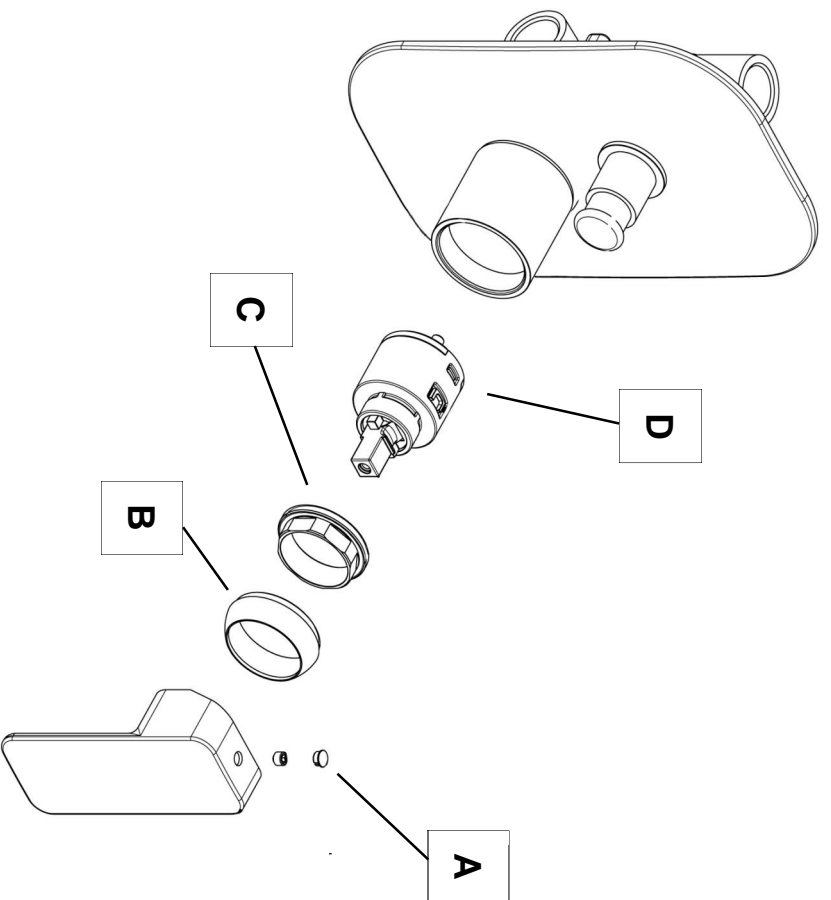

CLEANING THE CARTRIDGE
The concealed cartridge should give trouble free service, but in the event of any problems, servicing is straight forward.
First shut off the water supply to the tap. Pull out the cap (A) from the handle and with an allen key loosen the grub screw in handle, but do not remove it. Take off the handle, unscrew the cartridge cover (B) and carefully using a correct size spanner unscrew the retaining nut (C) and remove the cartridge (D). Wash the cartridge with clean running water and make sure that any trapped debris have been removed. Dry and lightly grease the seals (only use silicone grease) and replace the cartridge, retaining nut, cartridge cover followed by the handle.

CLEANING

The chrome plate we use on our taps is very durable, nevertheless care should be taken when cleaning them. They should be cleaned only with warm soapy water followed by rinsing with clean water and drying with a soft cloth. All finishes are vulnerable to acid attack and some strong substances such as household cleaners, disinfectants, denture cleaners, hair dyes, wine making and photographic chemicals can cause the surface to go black or peel.