

Armitage
Shanks

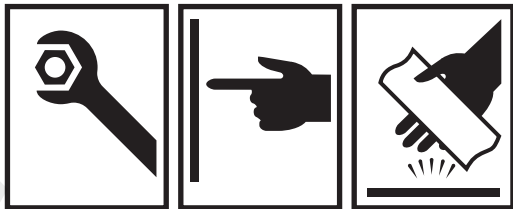

Markwik 21+ Sensor operated thermostatic mixers

INSTALLATION INSTRUCTIONS



A6684AA Markwik 21+ panel mounted mixer, sensor operated – timed flow (demountable) with removable spout & Armitage Bioguard outlet.

A6737AA Markwik 21+ panel mounted mixer, sensor operated – timed flow (demountable) with fixed spout & Armitage Bioguard outlet

Important:

- 1. Electrical connection:** these mains powered sensor operated products must be connected to a continuous permanent power supply.
- 2. Sensor protector:** this black-out lens cover should only be removed from the sensor after completing installation & at least 20 seconds after powering up.

See page 3 for more details.

IMPORTANT
BEFORE CONNECTION, FLUSH WATER THROUGH PIPEWORK TO REMOVE ALL DEBRIS ETC. WHICH COULD DAMAGE THE VALVE MECHANISM

INSTALLER: After installation please pass this instruction booklet to user

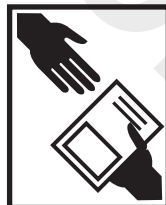

TABLE OF CONTENT

1	TABLE OF CONTENT	2
2	IMPORTANT PRE-INSTALLATION NOTES	3
	2.1 DESCRIPTION.....	4
3	PRODUCT BOX CONTENTS	5
	3.1 TIMED FLOW MIXER DIMENSIONS	6
4	WATER SUPPLY CONDITIONS	7
	4.0 WATER REGULATIONS.....	7
	4.1 INTRODUCTION.....	7
	4.2 SUPPLY PRESSURE REQUIREMENTS	7
	4.3 HEALTHCARE ESTABLISHMENTS.....	7
5	INSTALLATION: FIXATION	8
6	INSTALLATION: PLUMBING	8
	6.1 FLUSHING.....	11
7	INSTALLATION: ELECTRICAL	12
8	OPERATION & SENSOR ADJUSTMENT	15
9	COMMISSIONING AND AUDITS	16
	9.1 THE PURPOSE OF COMMISSIONING:	16
	9.2 COMMISSIONING PROCESS.....	16
	9.3 AUDIT CHECKS ON TMV'S	16
	9.4 AUDIT PROCEDURE	18
	9.5 IN-FIELD 'COLD WATER ISOLATION'(CWI) TEST.....	19
	9.6 SETTING TEMPERATURE FOR SENSOR OPERATED MIXERS.....	20
10	SERVICING - TVM3 SCHEME	20
	10.1 FREQUENCY OF REGULAR SERVICING	20
11	MAINTENANCE OF IN-LINE COMPONENTS	20
12	MAINTENANCE	21
	12.1 ADJUSTMENT OF THE MIX TEMPERATURE:.....	21
	12.2 REMOVAL AND INSPECTION OF CARTRIDGE	21
	12.3 IMPORTANT NOTES ON DEBRIS	22
	12.4 THERMOSTATIC CARTRIDGE AGEING	22
	12.5 ARMITAGE BIOGUARD OUTLET	22
	12.6 MAINTENANCE CLEANING.....	22
	12.7 HYGIENE FLUSH (AUTOMATIC).....	23
	12.8 SOLENOID VALVES	24
	12.9 SPOUT REMOVAL.....	25
	12.10 DEMOUNTING MIXER	26
	12.11 DISINFECTION SOLUTION	27
	12.12 STRAINERS.....	28
13	INTEGRAL ISOLATION VALVES	28
14	COMBINED CHECK VALVE REGULATORS	29
15	MARKWIK 21+ ACCESSORIES	30
16	SPARE PARTS - ELECTRICAL	31
17	SPARE PARTS	32
	SPARE PARTS LIST - MIXER	33
18	CLEANING CHROME SURFACES	34

2 IMPORTANT PRE-INSTALLATION NOTES



MAINS ELECTRICAL POWER SUPPLY

Mains powered Sensor Operated Products must be connected to a (fused / switched) **continuous permanent power supply**.

Connection to an **interrupted power supply** intended to stop electrical consumption in an unused facility, may adversely affect this sensor product and is therefore not recommended.

Each time the power supply is reinstated the product briefly enters reprogramming mode.

During reprogramming mode, any interaction (passive or active) with the product may alter the sensor settings in respect to range and / or run duration.

No significant savings will be achieved by connection to an interrupted supply. These products are intrinsically economical in terms of both water and electrical energy and will shut down in the event of a sensor being obstructed.

SENSOR PROTECTIVE COVER

This product is supplied with the sensor lens covered over with a black-out material.

DO NOT REMOVE this lens cover until the product installation has been completed & then wait for at least 20 seconds after powering-up.

The lens cover prevents the sensor from being unintentionally reprogrammed during the powering up sequence.

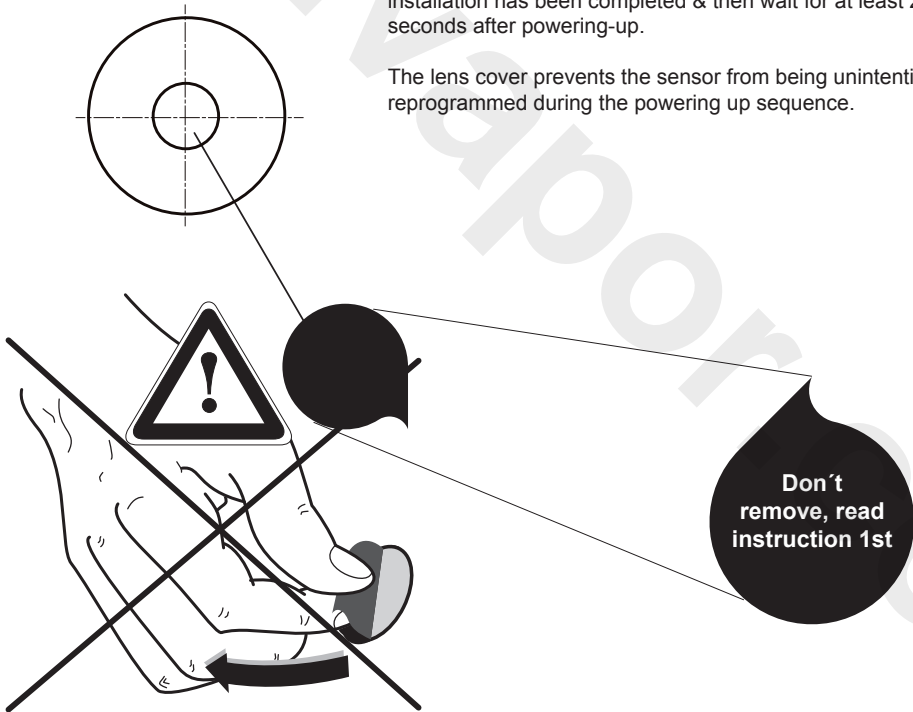

DURING SETTING UP PROCEDURE AVOID HIGH VISIBILITY CLOTHING

2.1 Description



Markwik 21+ panel mounted mixers (demountable) With fixed or removable spout & Armitage Bioguard outlet

A6684AA
A6737AA

Markwik 21+ mixer, sensor operated -removable spout – time flow

Markwik 21+ mixer, sensor operated - fixed spout – timed flow

This manual covers the Markwik 21+ range of time flow operated, panel mounted, thermostatically controlled mixers. These are designed to provide water at a preset temperature for hand washing. The time flow controls allow operation of the flow without the user having to touch the mixer.

These products are fitted with an Armitage Bioguard outlet which reduces the opportunity for bio film attachment and is lined with anti-microbial copper.

A hygiene flush (automatic) is an important optional feature of these products which can be enabled by the installer or maintenance staff using the optional remote programming unit. The hygiene flush is used to combat periods of low usage of the product. The program monitors and permits the fitting to be run automatically if it hasn't been used for a set time period. This feature ensures regular movement of water preventing stagnation, thus combating bio film growth and bacteria colonisation. See section 12.7 for more details.

Two timed flow models are covered one with removable spout and one with fixed spout. Flow starts when the user's hand enters the detection zone and shuts off after a pre-set time. The pre-set time can be adjusted. Traditionally the sensor is mounted to the right of the fitting, but it can be mounted to the left if necessary.

They are both intended to be installed on duct panel walls. The panel thickness should be in the range 13 - 27 mm. Two holes, of diameter 30mm nominal and one at 35mm nominal, will need to be cut in the panel at centres defined in Figures 1 & 2

The hot side of the mixer is insulated to ensure the body surface is maintained at a safe temperature when the fitting is in operation.

These mixing valves are supplied complete with integral isolating valves, strainers, check valves and flow regulators. They have a built-in thermal shock feature, using the special tool provided, the maximum blend stop to be overridden up to the full hot water supply temperature in the system.

These Markwik 21+ products permit quick & easy removal of the mixer. The spout can also be removed for cleaning, disinfection & maintenance purposes on mixer A6684AA



Abbreviations & terminology used

PSU: Power Supply Unit - mains version only.

PCB: Printed Circuit Board - inside the PSU.

RCD: Residual Current Device.

SELV: Safety Extra Low Voltage

3 PRODUCT BOX CONTENTS

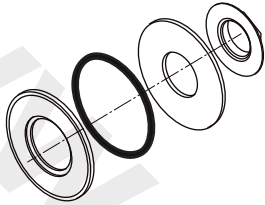

Fixing kit for mounting mixer. Includes 2 off each: back plates, o-rings, slip washers & back-nuts.

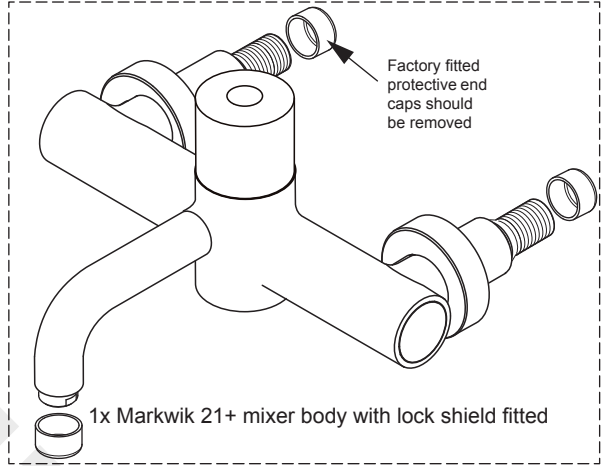

1x Markwik 21+ mixer body with lock shield fitted

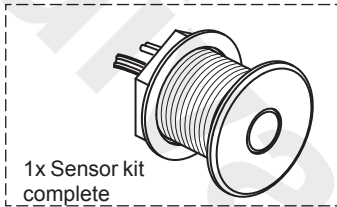

1x Sensor kit complete

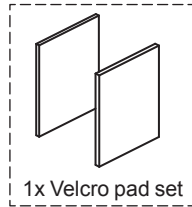

1x Velcro pad set

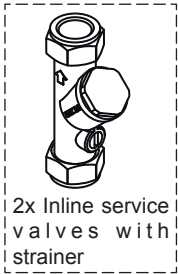

2x In-line service valves with strainer

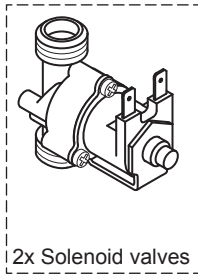

2x Solenoid valves

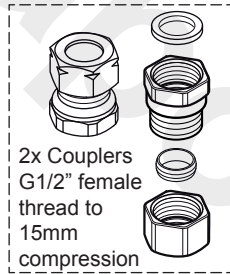

2x Couplers G1/2" female thread to 15mm compression

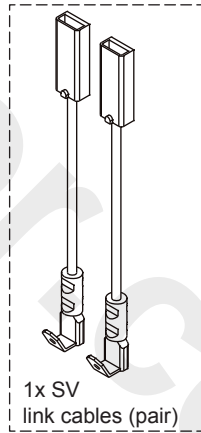

1x SV link cables (pair)

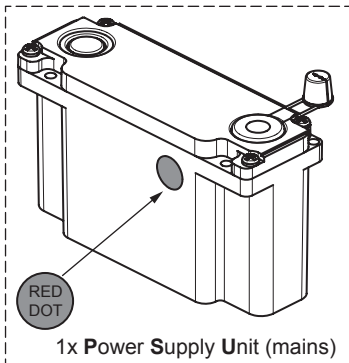

RED DOT

1x Power Supply Unit (mains)

3.1 Timed Flow Mixer Dimensions

In healthcare applications the height of the fixation holes above the "waste appliance" should be selected to create the recommended "activity space" as defined in HBN 00-10 Part C, typically 150mm – 200mm for a basin and 250mm – 300mm for a surgeon's scrub up trough

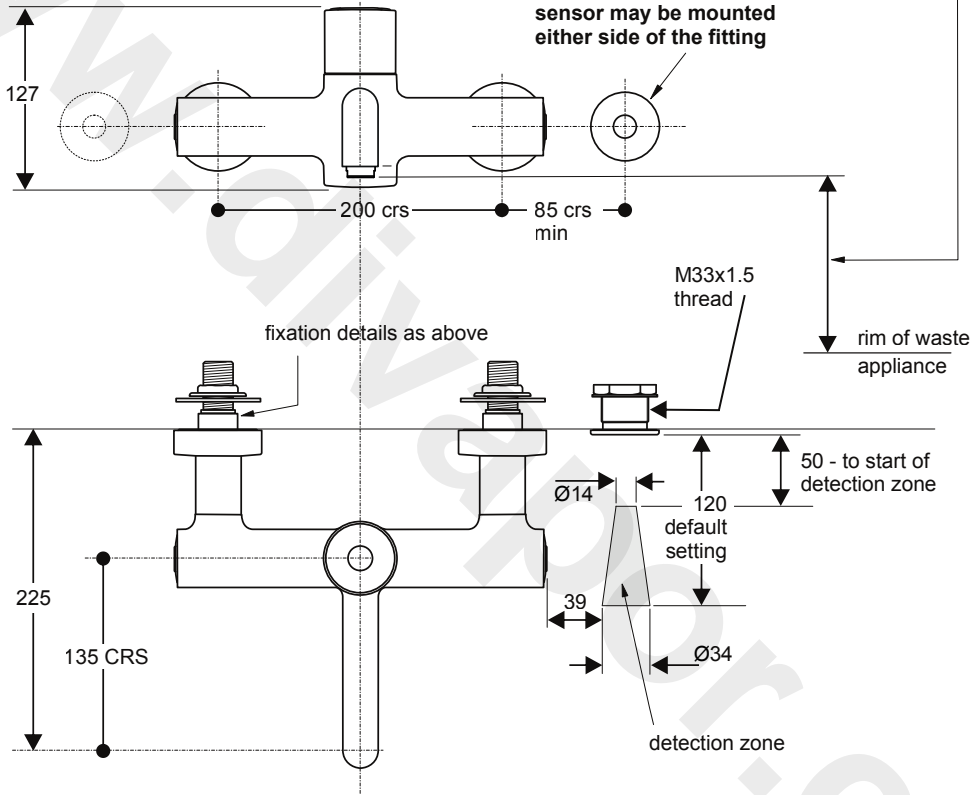

IMPORTANT: Prior to installing mixer, ensure that any existing thermostatic mixing valves (TMVs) that may be fitted are removed

4 WATER SUPPLY CONDITIONS

4.0 Water regulations

The fittings covered by this installation and maintenance instruction should be installed in accordance with the Water Regulations published in 1999*, therefore Armitage Shanks would strongly recommends that these fittings are installed by a professional installer.

*A guide to the Water Supply (Water Fittings) Regulations 1999 and the Water Byelaws 2000, Scotland is published by WRAS (Water Regulations Advisory Scheme)
Unit 13, Willow Road, Pen-y-Fan Industrial Estate, Crumlin, Gwent,
NP11 4EG. ISBN 0-9539708-0-9

4.1 Introduction

These timed flow thermostatically controlled mixers are manufactured to the highest standards and have approval to TMV3 which permits them to be installed in healthcare establishments such as hospitals, nursing homes and residential care homes. When installed in healthcare establishments the supply conditions detailed in Table 1 must be observed and the commissioning and servicing requirements detailed on section 9 & 10 must be followed.

For other installations this is not a requirement.

4.2 Supply Pressure Requirements

This mixer is designed to be installed on all types of plumbing systems.

Hot and cold water supply pressures should be reasonably balanced, however, the mixer will function within specification on unequal pressures up to 5 :1.

The mixer has integral isolating valves which permit servicing of the strainer, combined check valve regulator & thermostatic cartridge. They are also used for Cold water isolation testing.

The minimum pressure for the correct thermal operation is 0.6 bar.

4.3 Healthcare Establishments

In accordance with the NHS model engineering specifications DO8 this valve has approval for the following applications:-

High Pressure	HP-	-WE
Low Pressure	LP-	-WE

For this type of application the following supply conditions must apply:

Operating pressure range:	High Pressure	Low Pressure
Maximum static pressure	10 bar	10 bar
Flow pressure hot and cold	1 to 5.0 bar	0.6 to 1.0 bar
Hot supply temperature	55 to 65 °C	55 to 65 °C
Cold supply temperature	5 to 20 °C	5 to 20 °C

Note:

Fittings operating outside these conditions cannot be guaranteed by the scheme to operate as **TMV3**.

Table 1 Supply conditions for healthcare establishments

Effectively this means:

Differential between HOT and COLD inlet temperatures (Δt) must be 32°C min and 60°C max

Differential between HOT inlet temperature and MIXED temperature (Δt) must be 11°C absolute minimum but > 14°C preferred

See 9.3 Audit checks on TMV's.

5 INSTALLATION: FIXATION

These mixers are designed to be panel mounted on a duct wall of maximum panel thickness 27mm. For thicker panels the rear of the panel will require counter bores of 62mm or greater around the fixation holes.

Cut two holes of 30mm diameter, horizontally aligned to 200mm centres in the wall. (See figure 1 for height positioning of the fitting body over a "waste appliance")

The sensor will require a hole of 35mm positioned as indicated in either fig4.

Loosen the chrome shrouds and insert the fitting as shown above with the wall plates and seals to the front of the wall. Put on the slip washers and do up the backnuts to a torque of 25 Nm Screw the shrouds onto the wall plates

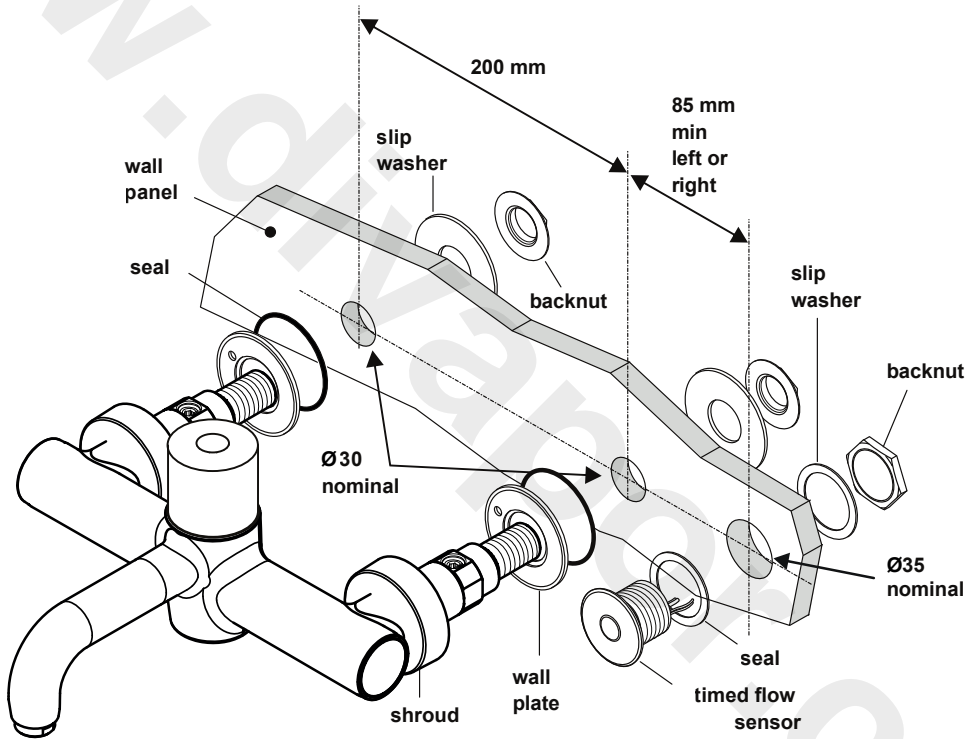

Figure 4 Timed Flow mixer installation - panel mounting

6 INSTALLATION: PLUMBING

Products covered in this manual are certified with the service valves provided.

Only if necessary (not recommended), use an equivalent service valve with integral strainer & isolating function.

NOTE FOR IRELAND: 15mm olives are supplied with this product. Use 1/2" olives if 1/2" supply pipes are fitted.

First refer to section 4. Supply conditions.
 A typical example of an installation of a proximity mixer is shown here as a guide. In this example, the water supply pipes are provided from above (this usually permits better drain down of pipes). Supplies can be from any direction.

This diagram shows the preferred method of assembling the plumbing components. Two of these assemblies are required per product. **OBSERVE ARROWS ON VALVE BODIES.**

IMPORTANT: Avoid using heat for soldering near the product inlets to prevent damage to internal components

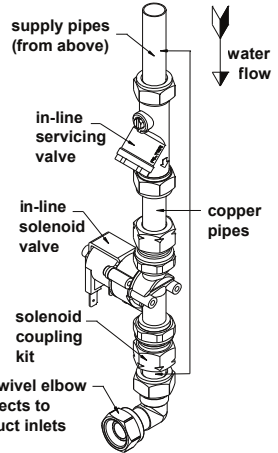

Fig 5 Overview of plumbing installation

Mount mixer to the panel and secure the backnuts.

Fit swivel elbows (15mm x G1/2, not supplied) to the inlet tails as shown and ensure the seals supplied with them are fitted between the inlet tails & the elbows. Make good the joints.

Prepare two short lengths of 15mm copper pipe (minimum of 45mm long) and assemble to the compression side of elbows. Make good the joints

IMPORTANT: When viewed from the REAR, the HOT supply should be connected to the RIGHT hand side.

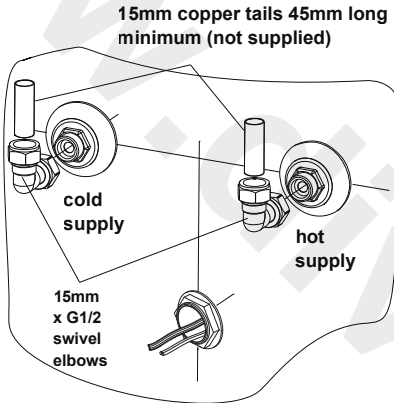

Fig 6 View from rear of proximity product showing it fixed to panel with backnuts, swivel elbows & copper tails

The coupling nuts (supplied) can now be screwed onto both sides of both in-line solenoid valves. Ensure the seals provided are fitted between the solenoids and the coupling nuts. Make good the joints, taking care not to use excessive force.

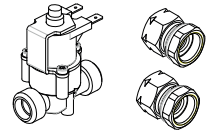
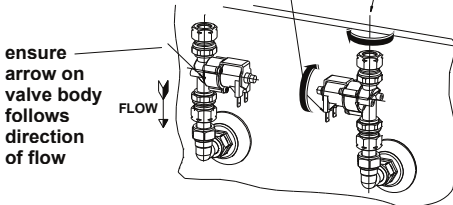

Fig 7 Solenoid valve & coupling nuts

solenoid coil is on a ratchet - permitting rotation of up to 90 deg in either direction about the horizontal axis shown

solenoid valves can also be rotated about the vertical axis into a position that permits easy access to connectors



The solenoid valve assemblies can now be loosely fitted onto the copper pipes.

IMPORTANT: Ensure directional arrow on valve body follows the direction of the water flow.

Position solenoid valves as required and then make good the joints

Fig 8 View from rear showing solenoid valves fitted onto copper pipes



DO NOT apply heat near this product. Heat generated by soldering could damage plastic parts and seals.

Check that all joints are securely tightened, test for leaks.

Installation: plumbing continued...

IMPORTANT: Ensure the arrows on the valves bodies match the direction of the water flow.

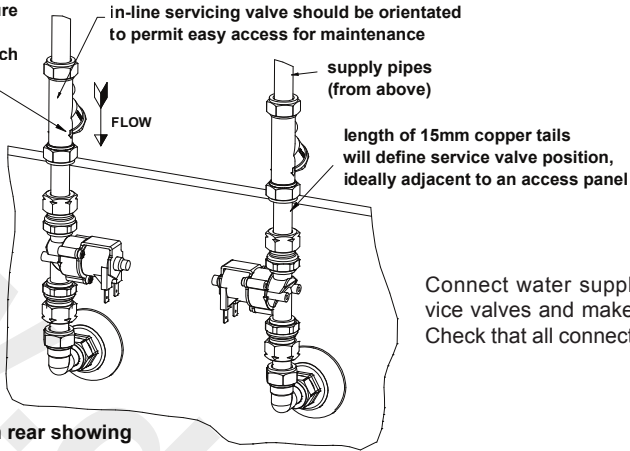

Fig 9 view from rear showing

Connect water supply pipes to the service valves and make good all the joints. Check that all connections are water tight.

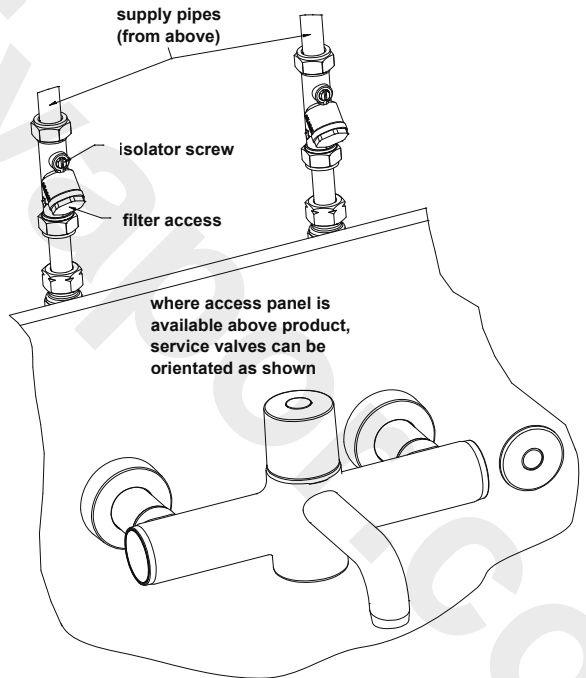
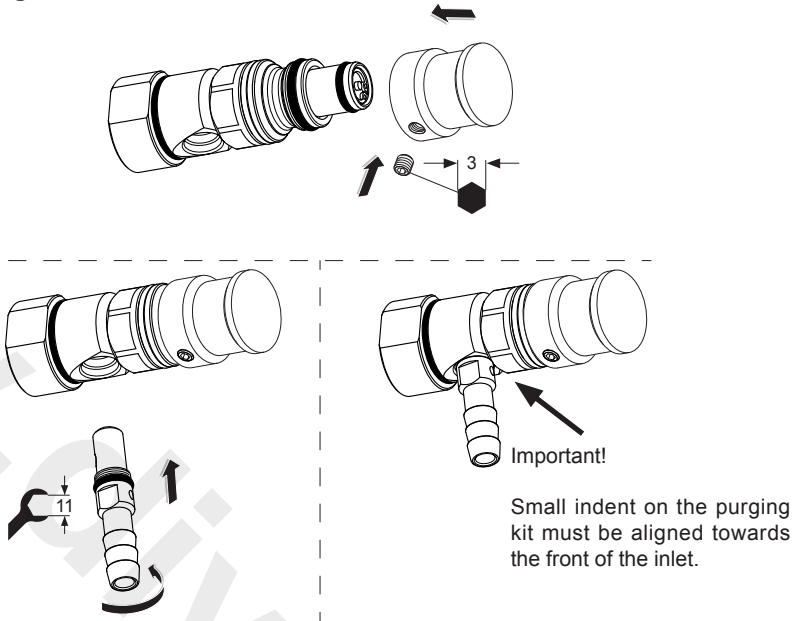

Fig 10 View from front showing service valves fitted to pipework

6.1 Flushing



IMPORTANT NOTE:

Before operating the product, it is strongly recommended to flush the pipe work to remove any residues or debris remaining after installation. A purge kit is available for this purpose. (See 15)

The purging kit also provides the facility to obtain water supply temperatures at the inlets

Safety Note: Care should be taken when carrying out the following procedure to avoid contact with hot water and hot surfaces. We recommend the use of protective hand wear.

The following procedure should be used to flush out the pipework:

1. Remove the strainer from the inlet with a 5mm hexagon key to gain access to the purging port. (See 12.12)
2. Screw the purging kit into the inlet port fully and then unscrew until the small indent on the purging kit towards the front of the inlet as shown.
3. Open the isolating valve and allow water to discharge into a vessel until the water flows clean. Suitable tubing can be push fitted onto the purging kits if required.
4. Repeat on the both sides of the mixer so that the hot and cold supplies are both flushed

Once the system has been flushed, remove the purging kits and refit the strainers using a 5mm Allen key.

Re-assemble the Chrome Inlet Sleeves and Panel Shrouds and secure the body back onto the inlets with a 3mm hexagon key..

7 INSTALLATION: ELECTRICAL

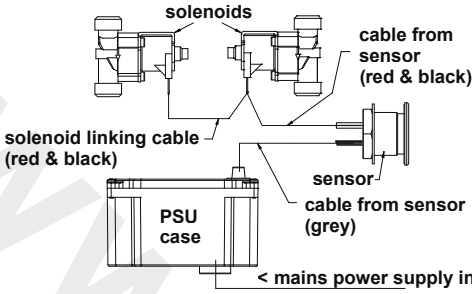

Fig11 Showing overview of electrical installation

With the product securely mounted to the panel & plumbed-in, electrical work can commence.

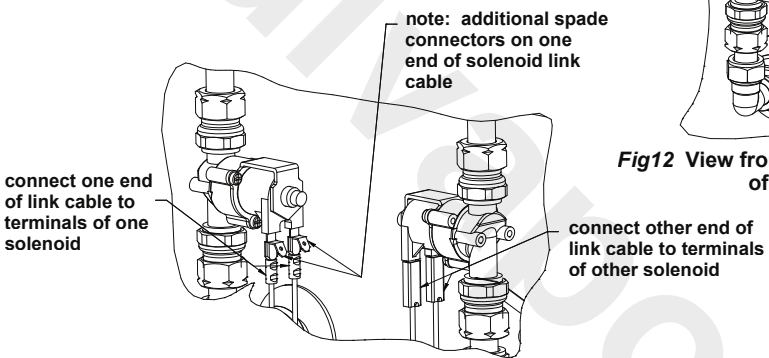

Fig13 View from rear showing solenoid valves link cable fitted

First connect the two solenoid valves together using the separate link cable provided. The link cable is black & red with connectors fitted at both ends. Cable length is 500mm.

Connect the cable to the solenoid valve terminals as shown. Observe the + and – symbols marked on the solenoid valves, connect the red cables to + & black to -.

Note: one end of this link cable is fitted with additional spade connectors as shown. These connectors are for attaching the red & black sensor cable.

Connection of this product to mains power supply should be undertaken by a competent person and should conform to IEE Wiring Regulations.

A typical example of an installation of a proximity mixer is shown here as a guide.

Orientation & position of solenoids, and PSU (Power Supply Unit) case can differ from installation to installation.

An overview of the electrical wiring is shown in Fig 11

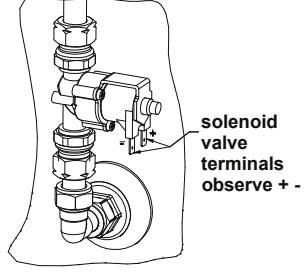
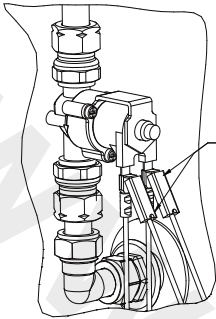

Fig12 View from rear showing one of the solenoid valves

Installation: electrical continued...



connect sensor cable onto additional spades

Locate the end of the red & black cable which is attached to the rear of the sensor. Cable length is 750mm.

Connect this cable to the spade connectors shown on the link cable. Observe + and – Ensure red is connected to red & black to black.

Fig14 View from rear showing sensor cable fitted to one solenoid valve

Next, open the PSU case by unscrewing 4x posi-drive screws; the lid & seal should separate from the PSU case. Slide out the PCB (Printed Circuit Board) from the case.

With the mains power switched off, prepare the mains power cable (not supplied). This should be flexible 3A rated 2 core cable. Carefully remove about 100mm of outer cable sheathing, strip the wire ends back by about 5mm.

Feed the cable through the grommet at the base of the case (cut small slot in grommet first).

Connect the appropriate mains wires to the L (Live) & N (Neutral) marked on the terminal block on the PCB.

Slide the PCB back into the case (note guide slots), allowing the mains wires to rest in-front of the transformer.

DO NOT leave wires on top of the transformer as this may prevent the lid from closing completely

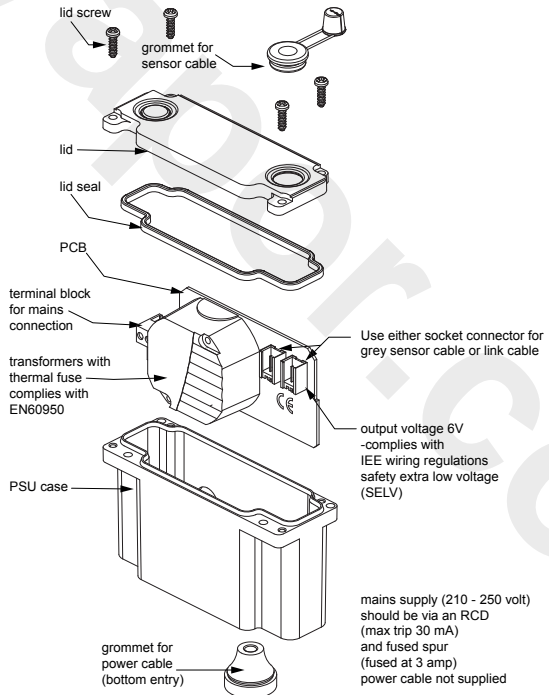

Fig15 Power Supply Unit (PSU)

Installation: electrical continued...

IMPORTANT: Ensure terminal block screws are firmly tightened & clamp the wires securely. Note earth connection is not required to PCB

Locate the end of the second cable (grey with black line) which is attached to the rear of the sensor (cable end has connector fitted, length is 750mm). The cable can be slid into the upper grommet (which is pre-slit) & fed through the lid.

Plug this cable into either one of the two connectors on the PCB. The lid can now be closed, ensure the grommet is pressed into the lid. Check that no cables are trapped under the lid, make sure the lid seal is in place, and then refit the 4 retaining screws.

A pair of self-adhesive Velcro-type pads are provided. Attach one to the side of the PSU case & the other to a suitable location on the rear of the mounting panel.

Note: ensure the selected location does not stretch/stress the cables. Consideration should also be given to keeping the PSU case within easy reach/access for maintenance staff. Fasten the PSU case to the mounting panel.

This completes the behind-panel installation work.

IMPORTANT: Leave the sensor protective sticker in place for at least 20 seconds after powering-on the product. See section 8 regarding sensor adjustment



Electrical information & approvals:



Power: **6W**

Input voltage:
100V - 240V~ 50 - 60Hz

Protection class: **II**

Approval EU:
EN 60950, EN 60335

Approval UL: **UL 1310**

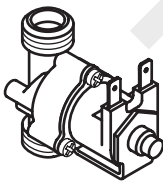

DIN EN 60730-1: Type 1



8 OPERATION & SENSOR ADJUSTMENT

Operation

Both mixers are operated when the user places a hand in the detection zone.

Flow will then continue for a preset time of 60 seconds and then stop automatically. The preset time can be adjusted by following the procedure outlined in the section on programming the sensor below.

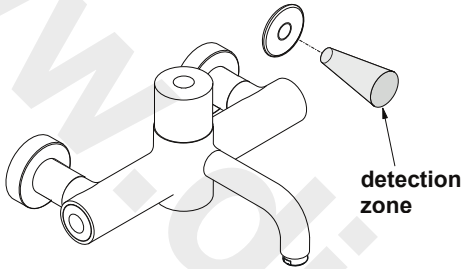

Figure 16

PROGRAMMING THE SENSOR

Follow this procedure to change the Detection Range and the Run Time

Step 1a Detection Range Adjustment

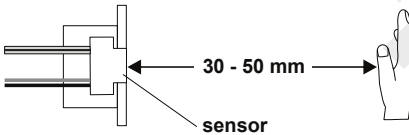

Figure 17

NOTE: Ensure there is no obstruction in the detection range during 'Power -Up' as this may cause the range to be changed.



Before programming remove sticky label over sensor face.

The sensor can only be programmed just after power-up.

Disconnect power supply from the mains, wait 30 seconds.

Reconnect sensor to power supply - note LED in sensor flashes slowly for about 5 seconds.

During this time, place hand 30 to 50 mm from sensor while LED flashes slowly.

Step 1b

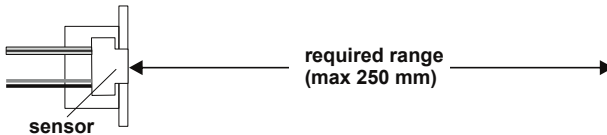

Figure 18

After the initial 5 secs, the LED will stop flashing and will stay fully on for about 5 more secs.

During this time, move hand to required range (up to a maximum of 250mm),

Leave hand at this position for 5 seconds, the LED will start to flash again.

If it is necessary to change the run time, go to Step 2 below, otherwise move hand away from detection range. The sensor now works normally and is no longer in programming mode.

If an error is made in programming the detection range, it is necessary to start again from Step 1a.

PROGRAMMING THE SENSOR CONTINUED

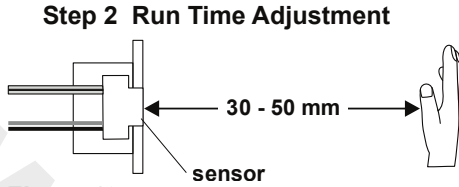

Figure 19

For other run times, see the table below. The sensor now works normally, and is no longer in programming mode. If an error has been made in programming the run time, it is necessary to start from Step 1.

While the sensor LED is flashing, hold hand near to sensor (30 - 50mm),

The sensor LED turns off and starts to flash very slowly (once every 2 seconds),

Each flash will give a different time period, after 7 flashes take the hand away from the detection range. The run time is now set for 60 seconds.

No of LED Flashes	1	2	3	4	5	6	7	8	9
Run Time (Seconds)	1	2	3.25	7.5	15	30	60	120	240

9 COMMISSIONING AND AUDITS

The following procedure should be conducted after installation to ensure the product is functioning correctly.

9.1 The Purpose of Commissioning:

- To confirm the correct designation of product versus application.
- To confirm the correct supply water conditions for the product / installation.
- To adjust the mixed temperature if necessary to suit the water supply conditions of the installation.
- To check the product is performing properly.
- To start an audit log and record appropriate data.

This product is factory set at $40 \pm 1^\circ\text{C}$ * with supplies of circa; 3 bar balanced pressure and temperatures of 15°C cold & 65°C hot (i.e. an inlet Δt of 50 & a hot / mix Δt of 24)

For supply requirements, see 4.0 Water supply conditions.

9.2 Commissioning Process (see decision tree FC1)

- Establish that the supply conditions are within the requirements of HTM 04 and the supply conditions outlined above. If not investigate.
- When conditions are acceptable record them, together with hot and cold temperatures. Establish Δt .

Check the outlet mix temperature is within $41^\circ\text{C} \pm 2^\circ\text{C}$ *, if not (probably due to $\Delta t > 5$ difference to factory setting) adjust appropriately. (See 12.1)

- If mixed water temperature is correct undertake an 'in field' cold water isolation (CWI) test (See 9.5).
Pass – restore supply and record mixed temperature,
Fail – See 9.5 in field 'Cold Water Isolation' test.

9.3 Audit Checks on TMV's

The purpose of a performance audit of a product is:

- To check the product continues to perform properly.
- To flag the need for the product to be adjusted due to supply condition changes or mechanism ageing.
- To ultimately identify the need for product maintenance.

Note - Additionally these audits facilitate regular verification of the supply conditions in accordance with HTM 04 requirements. (See decision tree FC3)

* See section 9.6: setting temperature

9.2 cont. Commissioning process (decision tree FC1)

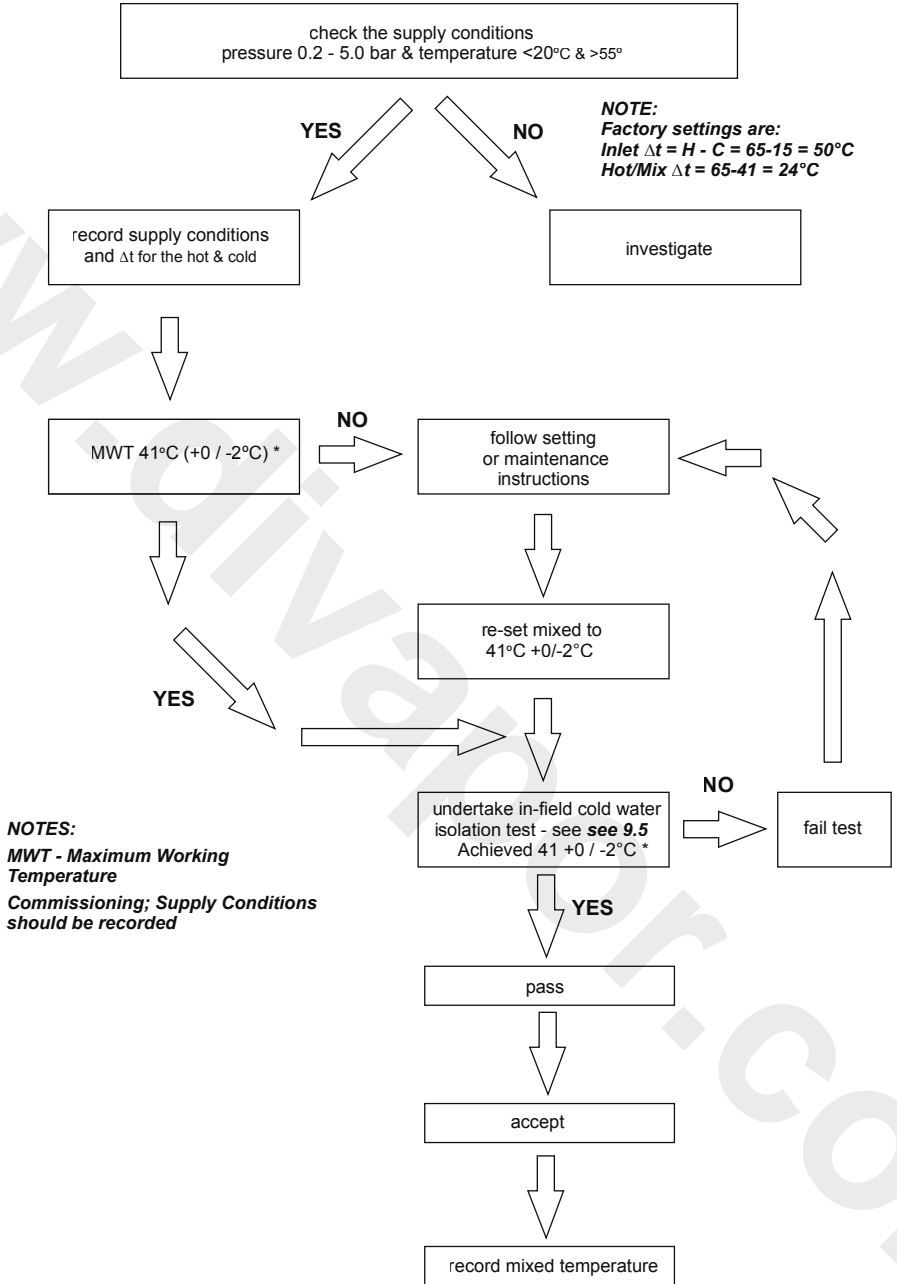

* See section 9.6: setting temperature

Audit of Supplies To Fittings (FC3)

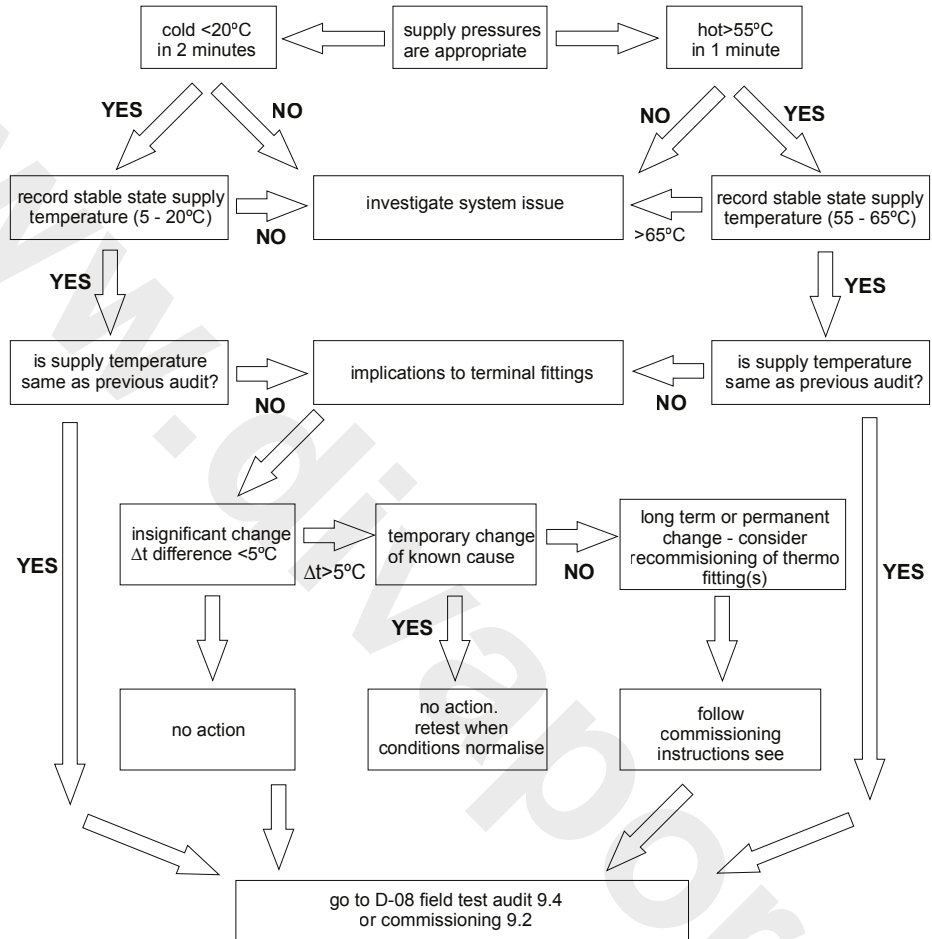

9.4 Audit procedure (see decision tree FC2)

- Verify the water supplies conditions are similar to when the product was commissioned i.e. inlet Δt as previous + / - 5°C
 Note: If inlet Δt change is $> 5^{\circ}\text{C}$ consider the cause of the change, If it is seen as a long term or permanent change, re-commission the product. If however, it is only a temporary change, retest when normal conditions resume.
- If inlet Δt differs from the commissioning Δt by $< 5^{\circ}\text{C}$ carry out field 'cold water isolation' (CWI) test as D-08: 2009. **See 9.5 in field Cold Water Isolation test failure.**
- Pass - restore the cold supply and move on to check the mix temperature.
 Note: If the product fails CWI test, refer to 9.5 and then re-commission the valve.
- Mixed Temperature is as commissioned $\pm 2^{\circ}\text{C}$, Accept and record the temperature.
 Note: If mixed Deviation $> \pm 2^{\circ}\text{C}$ (1st instance) reset mix as instructions and redo the test from start. **See 12.1 Adjustment of the mix temperature.**
- 2nd & subsequent instances follow maintenance instructions.

Fitting Field Test Audit (FC2)

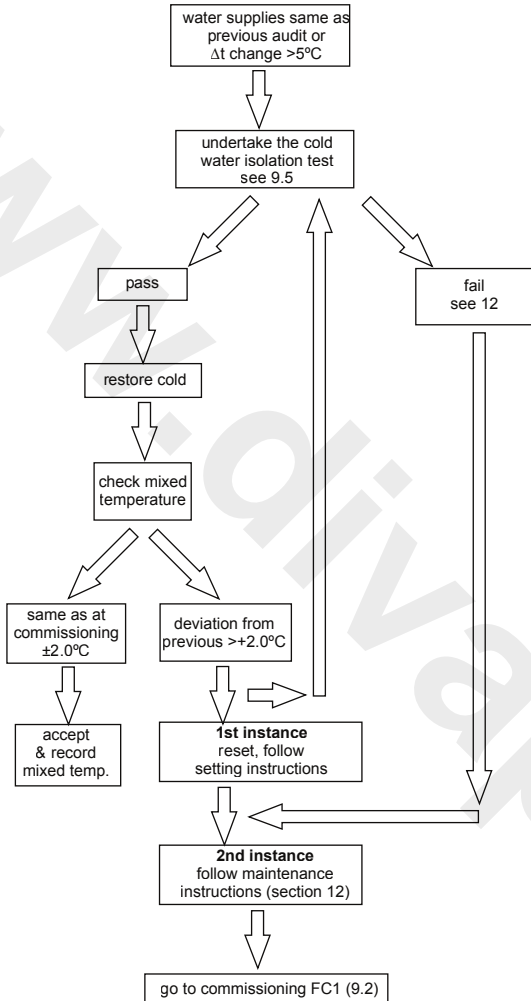

9.5 In-field 'Cold Water Isolation'(CWI) test.

Note: To gain access to the cold water isolating

valve, unscrew the right hand shroud & slide forward to expose the isolating screw on top of the cold inlet leg.

Using a 5mm Allen Key, The isolation plug can be screwed down fully to isolate the cold water supply

Prior to commencing the CWI test, ensure:

1. The water supply conditions are met either:
 - A. For commissioning a new product (see table 1, section 4).
 - B. Or the inlet Δt is within $\pm 5^{\circ}\text{C}$ to when the product was commissioned (see 9.4).

NOTE It is important that the hot temperature is greater than 55°C

2. Mixed water outlet temperature is correct (see table 2, section 10).

To perform a CWI test, operate the product using the sensor. Then conduct the following procedure:

1. Record the steady state temperature of both hot and cold water supplies. Note the Δt .
2. Record the temperature of the mixed water at the outlet.
3. Isolate the cold water supply & monitor the flow of water from the outlet.

If the flow ceases, CWI test passed:

1. Restore the cold water supply by rotating the isolator screw 90° clockwise.
2. Slide the shroud back & screw onto the wall plate.
3. Re-check the temperature of the stabilised mixed water at the outlet to ensure it is still correct.

Accept & record mixed temperature.

If there is an ongoing flow of water from the mixed water outlet, then 5 seconds after CWI collect the discharging water into a measuring vessel for 60 seconds. To pass the CWI test the volume of collected water should be less than 120ml.

If the product fails CWI test, see FC2 (section 9.4). Follow product maintenance (see section 12) and servicing (see section 10) instructions.

9.6 Setting temperature for sensor operated mixers

These products do not allow the user to select the desired blend temperature. We therefore recommend setting a blend temperature of 39 to 40°C rather than the normally applicable 41°C maximum associated with “user adjustable” products. This ensures comfort to more sensitive users.

10 SERVICING - TVM3 SCHEME

The need for servicing is normally identified as a result of the regular performance auditing.

Application	Maximum mixed water temperature during normal operation	Permitted maximum stabilised temperature recorded during site testing – excluding transient spikes
Washbasin	41°C *	43°C

Table 2 A guide to maximum temperature sets

* See section 9.6: setting temperature

10.1 Frequency of regular servicing

The purpose of servicing regularly is to monitor any changes in performance due to changes in either the system or the product. This may highlight the need to adjust either the supply system or the product. These products should be audited 6 to 8 weeks and again 12 to 15 weeks after commissioning. The results are to be compared against original commissioning settings.

If the product passes the audit test three consecutive times (demonstrating good stability of system & product) then a 12 monthly servicing cycle may be adopted.

Otherwise, servicing checks should be carried out more frequently (E.g. every 4 months).

Follow the recommended auditing and maintenance procedures detailed in sections 9 & 12. During servicing, note the following:

1. Repeat the procedure of recording and checking supply temperatures. (The same type of measuring equipment should be used)
2. If the temperature has changed significantly from the previously recorded values, the following should be checked:
 - a. All in-line or integral valve strainers are clear of obstruction.
 - b. All in-line or integral check valves are clean and working properly to prevent backflow.
 - c. Any isolating valves are fully open.
 - d. The thermostat is free of debris
3. When satisfied with the mixed outlet temperatures re-record the temperatures.

11 MAINTENANCE OF IN-LINE COMPONENTS

In this example, (see figure 25) the isolator screw slot is shown in the vertical position. This indicates the valve is open.

To close this valve, rotate the isolator screw by 90° into the horizontal position. By operating the product, this will drain down the water from the pipes below the service valve. Once the product has been isolated, this will permit maintenance staff to:

1. Check & clean the strainers by unscrewing the strainer cap.
2. Replace the in-line solenoid valves if necessary.
3. Completely remove the product from the panel if necessary.

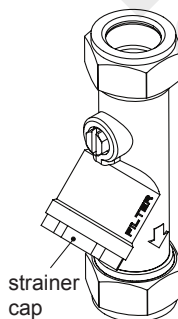

Figure 25 In-line isolating valve with strainer

12 MAINTENANCE

When installed as a TMV3 application it is a requirement that the commissioning and maintenance procedures, detailed under 9 & 10, be carried out.

12.1 Adjustment of the mix temperature:

- **Note: Cartridge is factory pre-set at $40 \pm 1^\circ\text{C}$ *.**
- Prise out the cover button, then use a 4mm Allen key to remove the screw.
- Lift off the lock shield.
- Remove both rotational stops from the spindle.
- Turn the spindle to achieve a $40 \pm 1^\circ\text{C}$ * mixed. (Clockwise to reduce and anti-clockwise to increase).
- Refit both stop rings against the anti-clockwise rotation stop face.

Note: 1. This is the normal maximum temperature range for the product and as such there is a wide zone of spindle movement that gives this mix temperature. For best performance you should refit the stop at the first point of anticlockwise rotation that achieves the desired setting.

2. If you are unable to achieve $40 \pm 1^\circ\text{C}$ * and you have the correct ?'s it may be due to fine debris. **See 12.2 Removal and inspection of cartridge.**

- Upon successful completion of the temperature adjustment, conduct the **Cold Water Isolation (CWI) test (See 9.5)** to ensure product is working properly.
- Refit the lock shield and record the mix temperature.

* See section 9.6: setting temperature

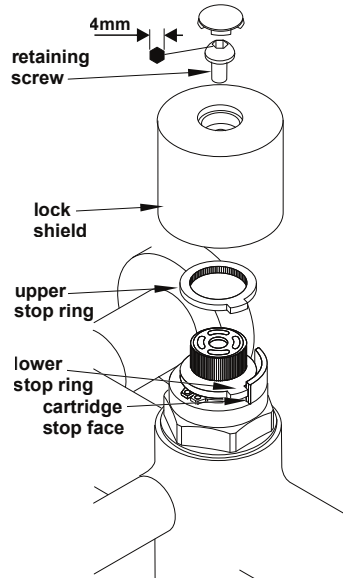

Figure 20 Adjusting the pre-set temperature

12.2 Removal and inspection of cartridge

After checking that supply conditions are within the specified parameters (see table 1), if the fitting malfunctions or should the test results fail to fall within the specified limits consider replacing the cartridge with a new one. **See 12.3 Important notes on debris.**

Isolate the fitting by rotating the integral isolating valves fully clockwise.

Remove the lock shield as described in 12.1. Unscrew the cartridge from the body with a 36mm a/f deep socket. Inspect cartridge for damage.

Replace cartridge if necessary and reassemble cartridge into body

The replacement cartridge should be tightened to a torque of 15Nm. (To re-secure the cartridge we recommend the use of Permabond A011 or equivalent applied to the thread of the cartridge)

Replace the lock shield and reinstate the supplies.

- **Redo the Cold Water Isolation (CWI) test (See 9.5).**
- Once satisfied with the CWI test, re-check and if necessary, adjust the maximum mix temperature, see (See 12.1).
- Record the mix temperature.

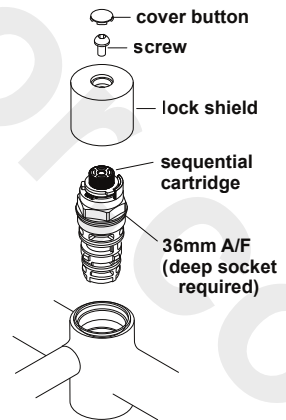

Figure 21 Exploded view showing sequential cartridge

Maintenance continued...

12.3 Important notes on debris

Although this product is protected by built-in strainers, debris can still find its way to the thermostat housing area. This can happen during servicing for example. Remove cartridge (see section 12.2) and carry out an inspection.

12.4 Thermostatic Cartridge Ageing

Following many years of normal service you may notice the following:

1. The need to carry out more frequent adjustment of mixed temperature.
2. The thermostatic element may not pass the CWI test.

These issues could be due to the ageing of the thermostat which loses some expansion capability over time.

These are the principle objectives of testing, as they serve to indicate to maintenance staff the declining performance capability of the thermostatic cartridge.

For this reason the audit testing flow chart highlights that 2nd Instance CWI test failure or 2nd instance mixed deviation even with stable 'as commissioned' supply conditions and correct inlet supply Δ 's, is potentially the first indication of the need to replace the cartridge.

12.5 Armitage Bioguard Outlet

Traditional "flow straightener" type outlets have recently been identified by extensive research as an area most likely to harbour bacteria. This product uses an Armitage Bioguard outlet which replaces this traditional flow straightener with a fully open copper-lined waterway. This greatly reduces the risk of bacteria build-up whilst the copper lining has natural anti-microbial properties.

Outlet is suitable for autoclaving.

In the interests of infection control and health hygiene, the Armitage Bioguard Outlet is a supplement to, not a substitute for, standard infection control practices. Continue to follow all current protocols, including those practices related to cleaning and disinfection of surfaces. Refer to HTM04-01 for more details.

Patent pending for Armitage Bioguard antibacterial outlet, application No: 10 2012 107 243.4

OUTLET FILTER: The Armitage Bioguard outlet can be removed (as described below) & replaced with a universal filter adaptor, see section 17. The adaptor will accept most filter types which are externally threaded M24x1

12.6 Maintenance cleaning

On a regular basis the outlet should be inspected and cleaned.

To unscrew and remove the outlet, use an adjustable spanner on the flats (20mm). To refit, hand tighten and then use the spanner until the outlet has bottomed in the bore. Take care not to over tighten.

In areas where lime scale build-up is prevalent this should be avoided by regular cleaning. If it should build up, it will have to be removed. An inhibited proprietary scale solvent can be used such a kettle descaling solvent but it is important to follow the manufacturer's guidelines. After descaling it is important to rinse the parts thoroughly in clean water. Clean carefully and do not use abrasive materials or scrapers

Note: Lime scale deposits should be removed prior to using any disinfection treatments.

Maintenance continued...

12.7 Hygiene flush (Automatic)

This hygiene flush is an important optional function of these products which can be enabled by the installer or maintenance staff using the optional remote programming unit (for part number see sect.18).

The hygiene flush is used to combat periods of stagnation due to low usage of the product. The function activates the spout automatically if it hasn't been used for a set time period. This function ensures regular movement of water combating bio film growth and bacteria colonisation.

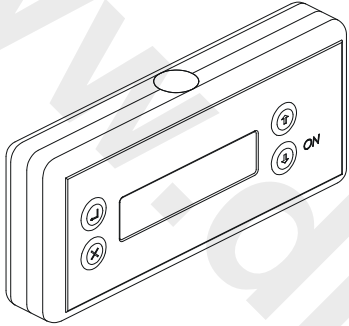

The programming unit should be held pointing towards the sensor at distance of approx. 100mm.

Once enabled, this function will automatically turn the water on for a duration of 1 to 240 seconds if the product has not been used for a period of 6, 12, 24, 48, or 72 hours.

For full details on how to enable this function, refer to the programming instructions supplied with programming unit.

Keep hand unit away from the water flow, avoid getting it wet.

A brief summary of how to navigate the programming unit is as follows:

- a) Handunit ON
- b) Navigate to Menu **4 PARAMETER**
- c) **SENSOR 2013** (Enter)
- d) **MENU 4.1 HAND-WASH** (Enter)
- e) **AUTO-RINSE FREQUENCY: OFF**
ARROW UP (To required Delay time) (Enter). Recommended: 6 or 12 hours.
- f) **AUTO-RINSE DURATION:** (15 sec default)
ARROW UP or DOWN (To required Run Time). Recommended: 60sec (max).
- g) Point towards Sensor (approximate distance 100mm)
- h) Press ENTER
- i) **TRANSMISSION OK** - if successfully programmed;
ERROR COMMUNICATION 2- if programming failed
- j) Press ESCAPE (X) to get **BACKUP FUNCTION**
- k) With BACKUP FUNCTION, previous settings are 'Remembered'
- just point at next Tap / Sensor and press ENTER to repeat.
- l) Handunit turns itself off after 2 minutes of non-use.

! Note: Older handset units will display (c) **SENSOR 2008** (or 2003) by default.

! Failed program output message will be (i) **ERROR.COMMUNICATION3**.

! Latest handset can program all previous sensor versions 2013, 2008 & 2003.

Maintenance continued...

12.8 Solenoid valves

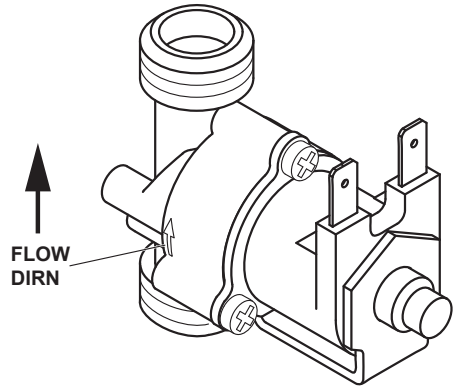

If water continues to flow when the tap should be off, and if the sensor is correctly ranged, then the solenoid valve may have debris lodged in the diaphragm pilot hole or on the valve seat:

- Locate the solenoid valve.
- Isolate the water supplies.
- Disconnect the solenoid valve cables.
- Remove the 3 screws holding the coil.
- Lift off the coil assembly.
- Locate the diaphragm (inside the valve body).
- Clean out the pilot hole(s) – use a thin gauge fuse wire (or similar).

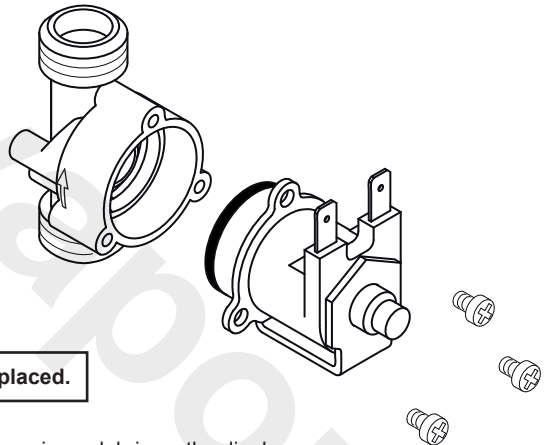

If diaphragm is damaged it should be replaced.

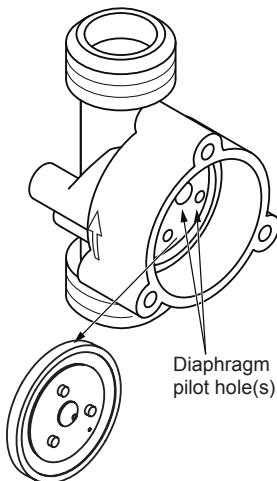

- Ensure there is no debris on the diaphragm or the valve seat (under diaphragm).
- Re-assemble solenoid valve.
- Reconnect water supply, check there are no leaks.
- Reconnect the solenoid valve cables.
- Test the solenoid valve & ensure it is working correctly.

If the solenoid plunger becomes dislodged from its bore, **ensure it is refitted correctly. The end with the small black insert should face towards the diaphragm.**

Incorrect assembly will cause continual running.



Maintenance continued...

12.9 Spout removal

This mixer is fitted with a quick easily removable spout to assist with cleaning, disinfection by immersion or sterilisation by autoclaving.

Procedure assumes availability of a replacement spout. For both practical functional reasons along with environmental contamination reasons, the mixer should not be left without a spout in place.

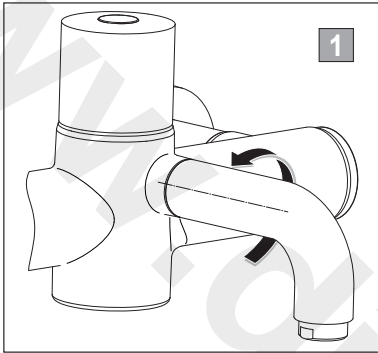

2. The spout should now be in the horizontal position as shown.

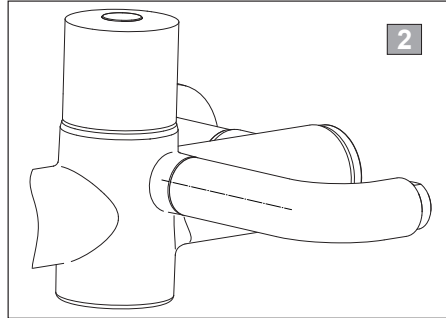

1. Ensure the handle is in the off position.
To remove the spout: gently rotate the end of the spout anticlockwise by 90°.

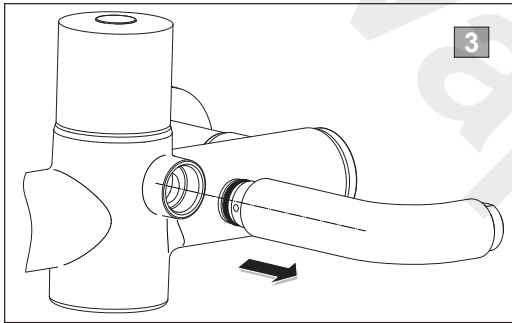

3. Gently pull the spout away from the body as shown.

Quarantine this spout for cleaning protocols.

Ensure replacement spout complies with cleaning protocols.

To refit a spout, reverse this procedure.

Cleaning / disinfecting / sterilising the removed spout.

Physical **cleaning** is only necessary if evidence of solid deposits e.g. calcium or similar can be seen around the outlet.

Disinfection can be achieved by immersing in an appropriate bactericidal solution, using this method we would strongly recommend removal of the Armitage Bioguard outlet from the spout prior to immersion. For disinfection solution **see section 12.11.**

Sterilisation can be achieved by autoclaving for the desired period. Complete spout can be autoclaved (NB; the seals can withstand this process).

Additional spouts are available so during cleaning protocols an alternative spout can be fitted while the original is removed. This insures continuity of use of the mixer.

For additional spout part numbers, **see section 17.**



IMPORTANT:
Do not leave the mixer outlet open without a spout fitted.

Maintenance continued...

12.10 Demounting mixer

In response to the new requirements of HTM 04-01 Addendum, the designs of these mixers have been enhanced to permit easy demounting of the mixer from the inlets.

This updated design permits quick & easy removal of the mixer for cleaning, disinfection (as **section 12.9** notes) & maintenance purposes.

Prior to commencing this procedure, you should have available either a replacement mixer (without inlets) or a pair of protective cover caps. **See section 17.**

IMPORTANT: For sensor operated products, DO NOT isolate mains power supply.

Method for demounting mixers:

1. Isolate the hot and cold water supplies using the integral isolation valves.
See section 13.
2. Undo the 2 grub screws securing the mixer using a 3mm hexagon key. (Take care not to lose the screws).
3. Remove the mixer from the inlets, by gently pulling away as shown. Expect some trapped water to escape.
4. During cleaning protocols:
Fit a replacement mixer (without inlets) to ensure continuity of use. Alternatively fit cover caps to protect & seal the inlets.
5. To refit the mixer; reverse this procedure. Tighten screws securely
6. Follow the commissioning procedure to ensure the product is functioning correctly. See section 9.

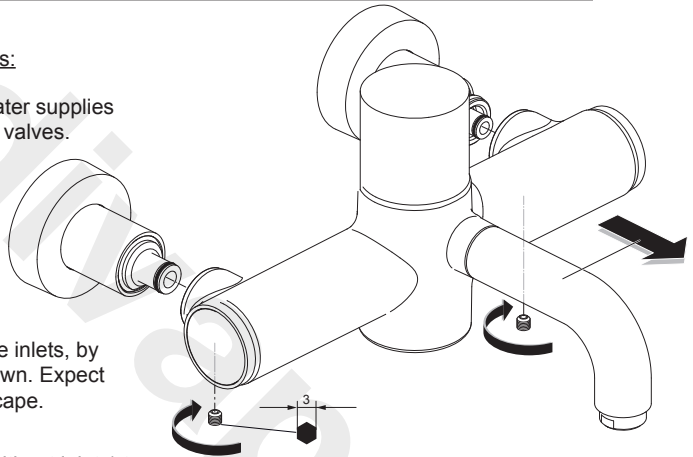

Disinfection by full immersion in an appropriate bactericidal solution is recommended for this assembly. Prior to immersion, the fitting should be clean and dismantled to a level that prevents air locking. In some cases it may be considered appropriate to dismantle the fitting prior to demounting.

The level of dismantling should be established as a result of practice and will be largely dependant upon the water quality and service life. As a minimum we recommend removal of the handle, thermostatic cartridge & the maintenance carriers in each side of the body. Cleaning the strainer screens on the latter is of great importance, see section 14. All components can be immersed together unassembled.

Disinfected mixers should be promptly replaced or stored using an appropriate method until required. For disinfection solution **see section 12.11**



Take care to avoid damaging the inlet seals. Damage to these seals would compromise the insulate feature & affect the mixer's thermostatic performance. See section 15 for spare "demountable seal kit".

Maintenance continued...

Protective cover caps

If a replacement mixer is not available, a pair of protective cover caps should be fitted to the inlets. For product code see section 18.

For both practical and functional reasons along with environmental contamination reasons, the inlets should not be left open.

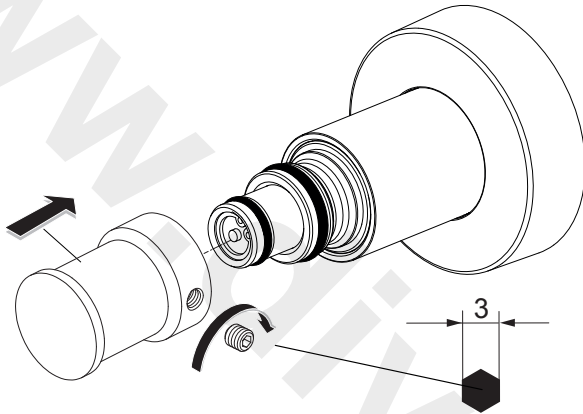

Push the caps onto the inlets until they stop against the shoulder. Take care not to damage the o-ring seals. Secure the caps with grub screws as shown using a 3mm hexagonal key. Leave the hot & cold supplies isolated. Cover caps should be disinfected / sterilised when necessary.



IMPORTANT:
Do not leave the mixer inlets open without a body or cover caps fitted.

12.11 Disinfection solution

As discussed in sections 12.9 & 12.10, for disinfection, we recommend parts be immersed in an appropriate bactericidal solution.

The frequency of such disinfection actions will be derived from regular sampling carried out under the regime of the Responsible Person (Water). We would not expect to need greater than 6 monthly frequencies, hopefully considerably less.

The need for excessive use of this procedure would be indicative of the need for some root cause analysis as there could be some system or behavioural problems that need addressing.

IMPORTANT ADMINISTRATION NOTE:

Where an audit log document (report or electronic record) is being kept for a mixer, consideration should be given to the mixer's traceability during the demounting & disinfecting process.

12.12 Strainers

To ensure trouble free operation of the mixer, the integral inlet strainer elements should be checked and cleaned at a frequency in accordance with the commissioning and servicing guide.

1. Unscrew and remove the Chrome Panel Shrouds and pull the Chrome Sleeves forward off the inlet seals.
2. Isolate both inlets by screwing the isolation valves down fully using a 5mm hexagon key in the clockwise direction. (Operate lever to confirm water supplies are closed off).
3. Undo the 2 grub screws securing the mixer using a 3mm hexagon key. (Take care not to lose the screws).
4. Remove the mixer from the inlets, by gently pulling forwards. Expect some trapped water to escape.
5. Unscrew and remove the strainers from the underside of the Inlets using a 5mm hexagon key
6. The strainers should be inspected and washed with clean water and can be Autoclaved or replaced as necessary
7. Before re-assembling the strainers we recommend flushing the inlets with our purging and water sampling kit - A6899NU (not included)

Removal and flushing procedure **SEE 6.1**

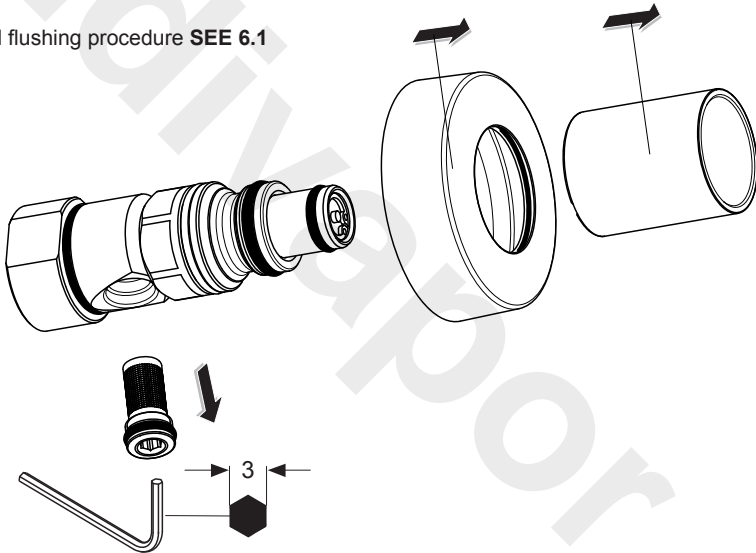

13 INTEGRAL ISOLATION VALVES

The integral isolation valves facilitate a number of activities:

- Servicing the thermostatic cartridge
- Audit Cold Water Isolation (CWI) test
- Demounting the mixer from its inlets

To isolate the mixers, proceed as follows:

1. Unscrew the wall shrouds and slide forward
2. Isolate both inlets by screwing isolation valves down fully using a 5mm Allen key in the clockwise direction
3. Reverse procedure to restore the water supplies and refit the shrouds

INTEGRAL ISOLATION VALVES continued...

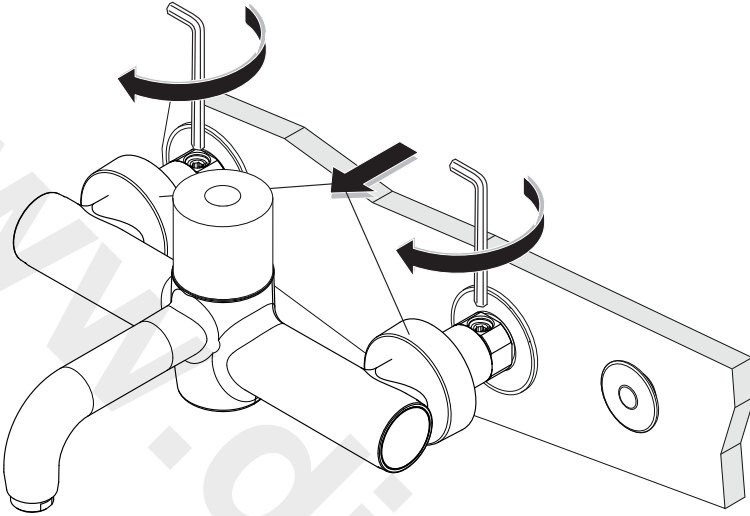

14 COMBINED CHECK VALVE REGULATORS

To prevent back siphonage of water to the supply pipes, check valve regulators (CV/FR's) are fitted inside the inlet tails at the front of the panel.

The CV/FR's can be replaced, but **MUST NOT BE REMOVED**.

Replacement Instructions

First remove the Ø12mm circlip using suitable internal circlip pliers.

The CV/FR can now be removed using long nose pliers; however there is a high probability of damage during removal.

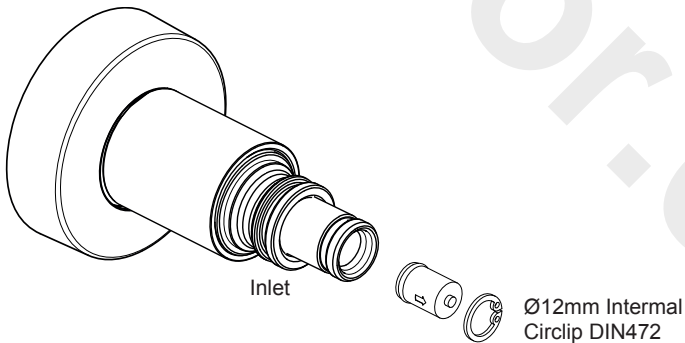

IMPORTANT:

The CV/FR's can be replaced but must not be removed

The pink CV/FR must be fitted to the cold water inlet (Right side of the mixer when viewed from the front)

The yellow CV/FR must be fitted to the hot water inlet (Left side of the mixer when viewed from the front)

15 MARKWIK 21+ ACCESSORIES

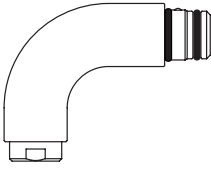

A6252AA

Panel mount spout complete.
Short version with 100mm reach.
Fitted with Armitage Bioguard outlet
& o-rings at the mixer coupling end.
See section 9.7

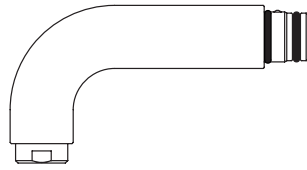

A6250AA

Panel mount spout complete.
With normal 135mm reach.
Fitted with Armitage Bioguard outlet
& o-rings at the mixer coupling end.
See section 9.7

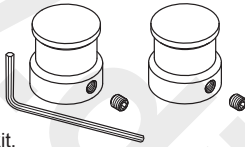

A6255AA

Cover caps kit.
To protect & seal the inlet legs when
a mixer has been demounted & removed.
See section 12.10



A6256AA

Universal filter adaptor.
Replaces the Armitage Bioguard outlet
to permit attachment of an outlet filter.
Threaded M24x1 (internal).

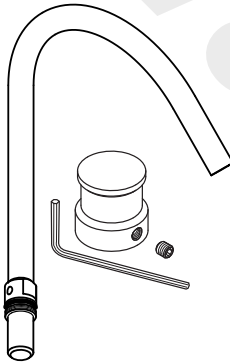

A6899NU

Panel Flushing set
See section 6.1

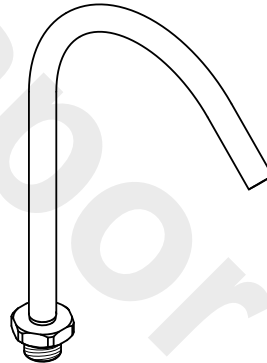

A6898NU

Deck Flushing set

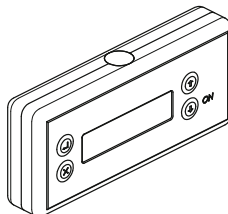

F960970NU

Remote programming
unit. See section

For more information on accessories contact our customer care.

16 SPARE PARTS - ELECTRICAL

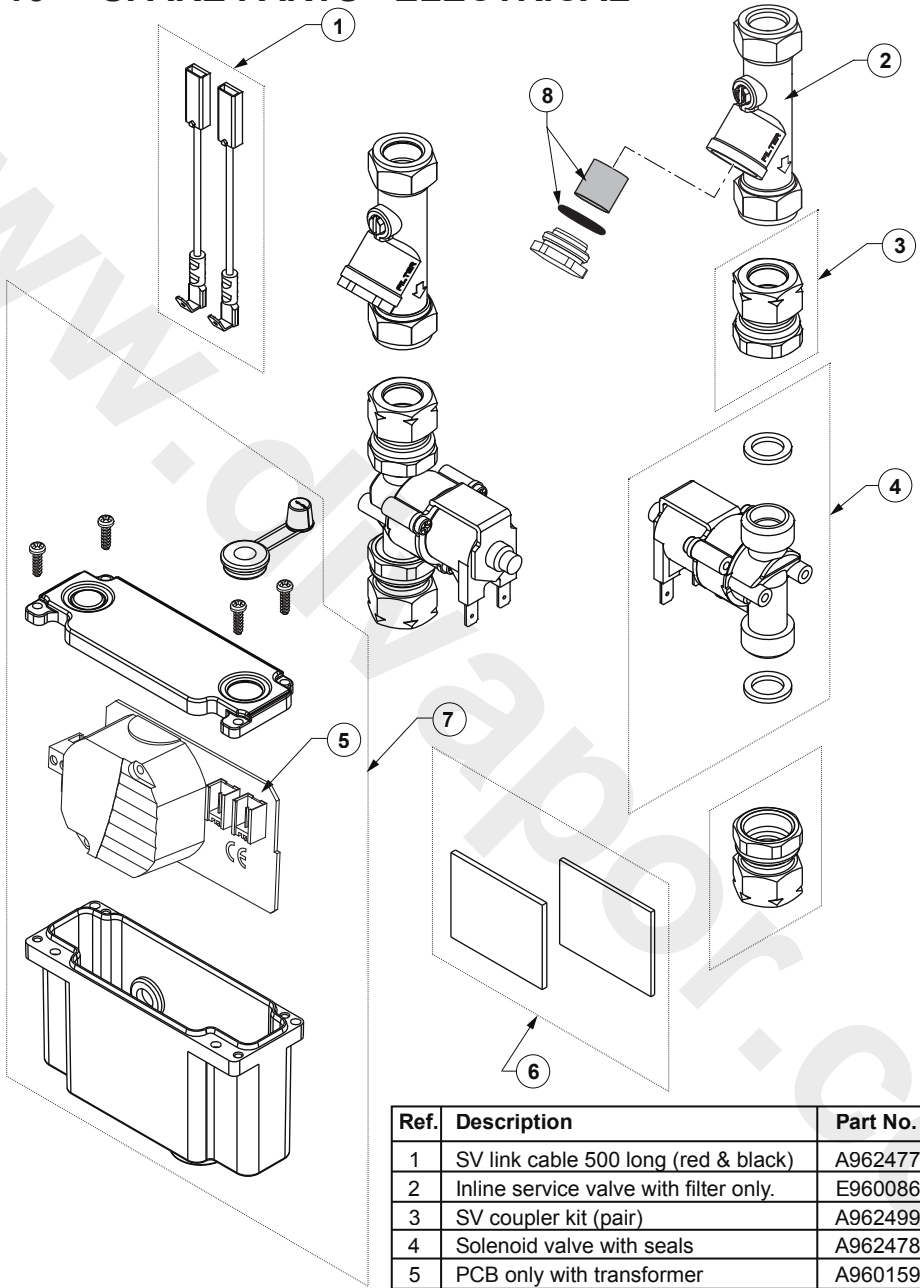
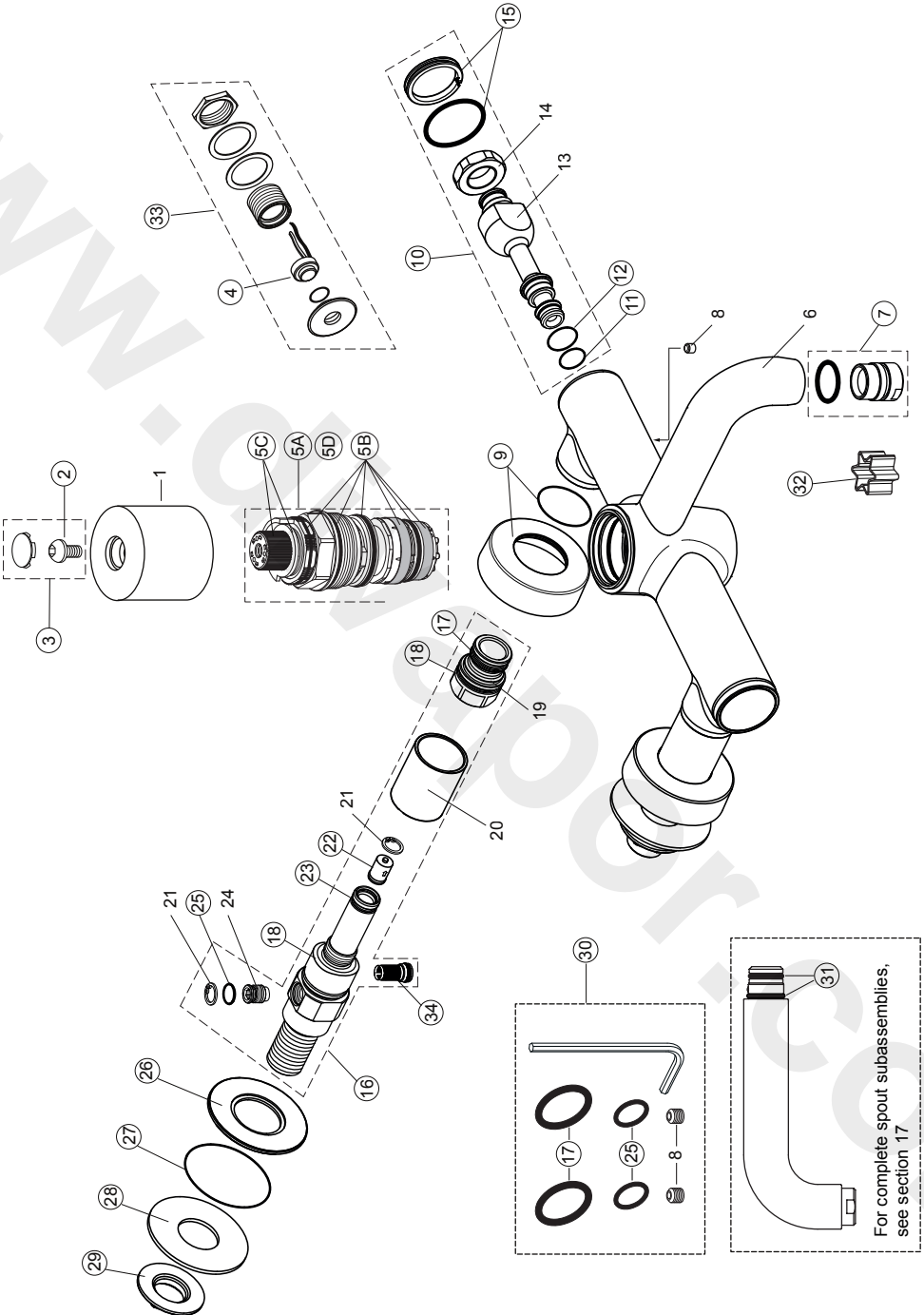

Figure 28 Behind Panel Spares

Ref.	Description	Part No.
1	SV link cable 500 long (red & black)	A962477NU
2	Inline service valve with filter only.	E960086NU
3	SV coupler kit (pair)	A962499NU
4	Solenoid valve with seals	A962478NU
5	PCB only with transformer	A960159NU
6	Velcro pad kit	A860704NU
7	PSU Complete	A962881NU
8	Strainer & O-ring kit (pair)	A861284NU

17 SPARE PARTS



For complete spout subassemblies, see section 17

Spare parts List - mixer

Ref.	Description	Part No.
1	Cap	--
2	Handle screw	A961950NU
3	Handle SET	E960615AA
4	Sensor IR complete with wire	A960219NU
5A	Sequential, thermostatic cartridge	A861165NU
5B	O - ring + stainer set thermostatic cartridge	A861166NU
5C	Splined cap & splined locking ring -cartridge	A861310NU
5D	Thermostatic cartridge –one stop ring - box of 10 pieces	A861290NU
6	Body	--
7	Outlet	F960847AA
8	Screw (available in 30 set)	--
9	Escutcheon + O-ring	A962346AA
10	Side sleeve cpl.	A861160NU
11	O - ring Ø 11 x 2	A960942NU
12	O - ring Ø 13 x 2	A861101NU
13	Sleeve	--
14	Threaded nut M18x1,5	--
15	Cap w. o - ring Ø 30 x 2	A861124NU
16	Inlet Set	A861161NU
17	O-ring 17 x 2.5	A963143NU
18	O - ring Ø 24 x 2,5	A961809NU
19	Inlet insulator	--
20	Inlet Sleeve	--
21	Circlip	A963143NU
22a	Combined CV&FR Ø10mm, cold water (pink) right side	A861215NU
22b	Combined CV&FR Ø10mm, hot water (yellow) left side	A861216NU
23	O - ring Ø 12,42 x 1,78	A961332NU
24	Isolations plug	--
25	O-ring dia 8.1 x 1.6 (single) - (available within item 16)	A962345NU
26	Wall plate	E960633NU
27	O-ring Ø51 x 2.4	E960632NU
28	SLIP WASHER Ø60 X Ø25 X 2	E960631NU
29	Backnut	E960112NU
30	Demountable seal kit with grub screws, o-rings & hex hey	A861162NU
31	O-ring Ø15 x 2.5	F961003NU
32	Brass flow straightener (star shape insert - optional)	S961044NU
33	Timed flow proximity sensor & housing	E960620AA
34	Strainer	A861172NU



For more information on spare parts why not visit our spare website:
www.fastpart-spares.co.uk
 or contact customer care

18 CLEANING CHROME SURFACES

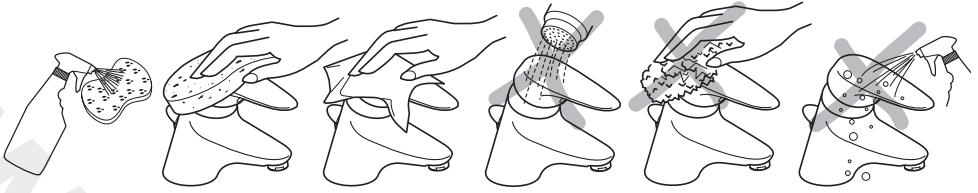

When cleaning chromed products use only a mild detergent, rinse & wipe dry with a soft cloth. Ideally clean after each use to maintain appearance.

Never use abrasive, scouring powders or scrapers. Never use cleaning agents containing alcohol, ammonia, hydrochloric acid, sulphuric acid, nitric acid, phosphoric acid or organic solvents. Use of incorrect cleaning products / methods may result in chrome damage which is not covered by the manufacturer's guarantee.

OTHER PRODUCTS WITHIN THE MARKWIK 21+ RANGE



A6682AA
Panel mount thermostatic mixer,
(Demountable) with removable
spout & Armitage Bioguard outlet

A6735AA
Panel mount thermostatic mixer,
(Demountable) with fixed spout
& Armitage Bioguard outlet

A6734AA
Deck mount thermostatic mixer,
(Demountable) with fixed spout
& Armitage Bioguard outlet



A6696AA
Markwik 21+ thermostatic basin mixer with
copper inlet pipes. Includes demountable
body, removable spout & Bioguard outlet

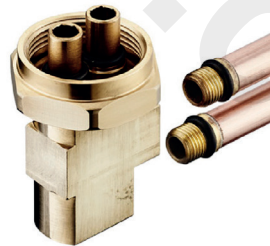

A6791NU
Markwik 21+ Back to
wall connecting kit for
closed wash basins

For more information about our products visit our websites:

www.armitage-shanks.co.uk

www.idealspec.co.uk

www.fastpart-spares.co.uk



AFTER SALES NON RESIDENTIAL HELPLINE

0870 122 8822

AFTER SALES NON RESIDENTIAL FAX

0870 122 8282

E-MAIL

aftersalesnonresidential@idealstandard.com

Armitage Shanks pursues a policy of continuing improvement in design and performance of its products.

This right is therefore reserved to vary specifications without notice.

Armitage Shanks is a division of Ideal Standard (UK) Ltd

Ideal Standard International NV
Corporate Village - Gent Building
Da Vincilaan 2
1935 Zaventem
Belgium

www.idealstandardinternational.com

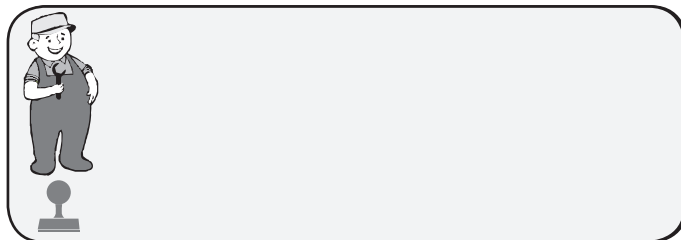

*Armitage
Shanks*

118 / A 868 249
Made in Germany