

Installation Instructions Thermostatic Built-In Shower Valves

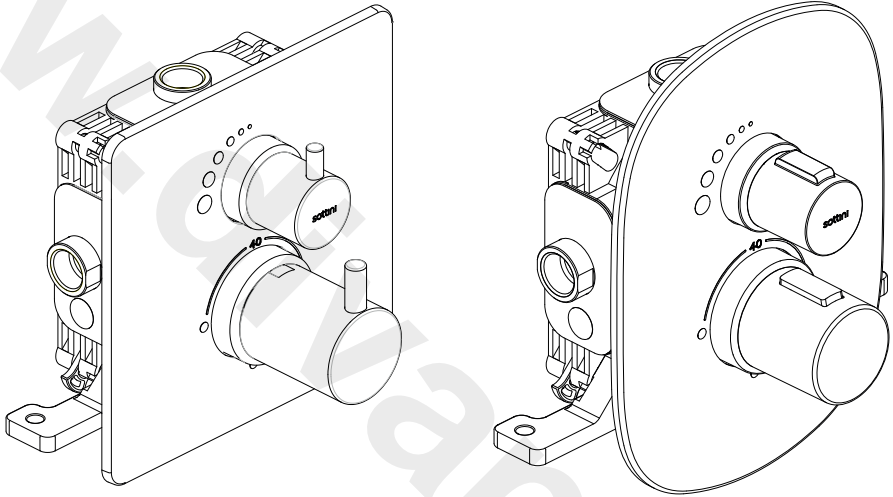

Low profile valves suitable for slim duct systems

Built-in dual-control thermostatic shower valves in this product range are:

A6453AA Oval escutcheon with on/off flow control

A6456AA Square escutcheon with on/off flow control

A6454AA Oval escutcheon with 3 function diverter (to bath, off, or shower)

A6457AA Square escutcheon with 3 function diverter (to bath, off, or shower)

A6455AA Oval escutcheon, with 3 function diverter (to shower, off, or shower head)

A6458AA Square escutcheon, with 3 function diverter (to shower, off, or shower head)

IMPORTANT

BEFORE CONNECTION, FLUSH WATER THROUGH PIPEWORK TO REMOVE ALL DEBRIS ETC. WHICH COULD DAMAGE THE VALVE MECHANISM

INSTALLER

After installation please pass this instruction sheet to user

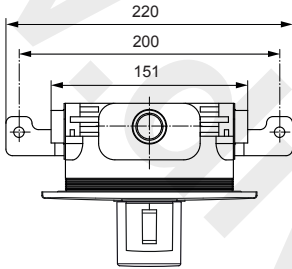
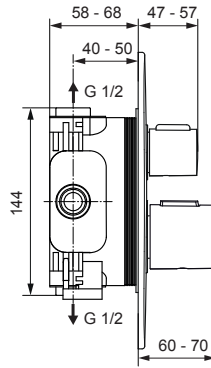
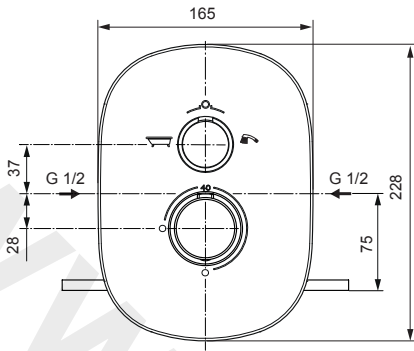

Inlets & Outlets are threaded G1/2".
The escutcheon plate can float 10mm
between min & max markers thus per-
mitting mounting depth to vary.

A6453AA oval escutcheon shower valve
shown with valve-box, trim & mounting bracket.

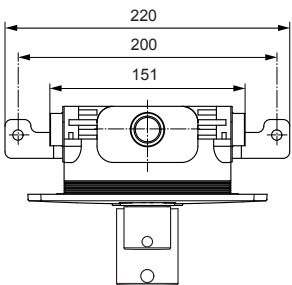
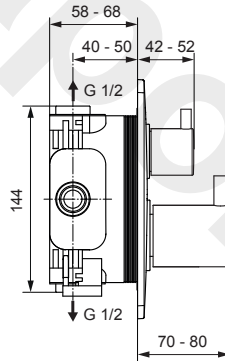
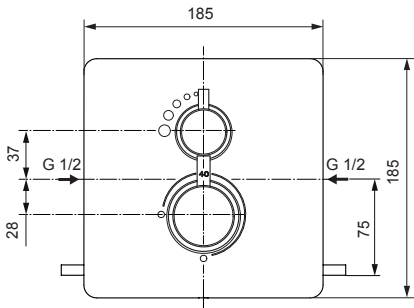

Inlets & Outlets are threaded G1/2".
The escutcheon plate can float 10mm
between min & max markers thus per-
mitting mounting depth to vary.

A6456AA square escutcheon shower valve.
shown with valve-box, trim & mounting bracket

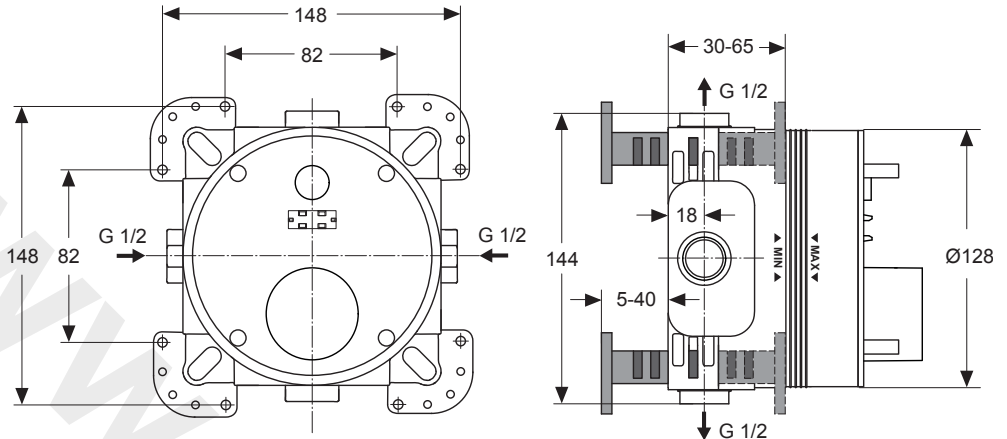

Valve-box dimensions with OPTIONAL legs fitted

Suitable outlet devices

For information about our other products visit our website (See back page for details). Or contact our customer care.

Sottini products include a wide selection of:

- Over head shower outlets
- Tub filling devices & outlet spouts
- Shower kits with sliding rails

TABLE OF CONTENT

1 INTRODUCTION	5
2 SUPPLY CONDITIONS	6
3 WATER REGULATIONS	7
4.0 PRE-INSTALLATION NOTES:	8
4.1 OVERVIEW OF KITS 1 & 2.....	8
4.2 KIT-1 MOUNTING DEPTH CONTROL.....	8
4.3 MOUNTING OPTIONS, QUICK OVERVIEW	10
4.4 WALL TYPES, QUICK OVERVIEW.....	11
4.5 VALVE-BOX ORIENTATION.....	11
4.6 KIT-1 DESCRIPTION	12
4.7 VALVE-BOX SEALING SYSTEM	13
5.0 INSTALLATION GUIDE – KIT.1	14
5.1 CONNECTING PIPE-WORK - PRELIMINARY	14
5.2 MOUNTING METHODS.....	15
5.3 USING OPTIONAL ADJUSTABLE FIXING LEGS (METHOD C)	16
5.4 MOUNTING VALVE-BOX INTO A SOLID WALL	17
5.5 MOUNTING VALVE-BOX INTO A PRE-FABRICATED POD WALL	19
5.6 MOUNTING VALVE-BOX INTO A PANEL	20
5.7 MOUNTING VALVE-BOX INTO A TIMBER STUD WALL.....	21
5.8 COMPLETING PIPE-WORK	23
5.9 EXAMPLES OF INSTALLATIONS.....	23
6.0 PREPARATION FOR CHROME TRIM (KIT-2).....	29
6.1 DESCRIPTION OF CHROME TRIM (KIT-2).....	30
6.2 INSTALLATION OF CHROME TRIM (KIT-2).....	30
6.3 PRODUCTS WITH INTEGRAL DIVERTER	33
7 OPERATION	33
8 MAXIMUM TEMPERATURE STOP	35
9 CALIBRATION OF THERMOSTAT	35
10.0 ISOLATING VALVES & MAINTENANCE	35
10.1 COMMISSIONING & PERIODIC CHECKS.....	36
10.2 FREQUENCY OF REGULAR SERVICING.....	36
11 THERMOSTATIC CARTRIDGE REPLACEMENT.....	37
12 FLOW CARTRIDGE REPLACEMENT	38
13 DIVERTER CARTRIDGE REPLACEMENT	38
14 CHECK-VALVE CARTRIDGE REPLACEMENT	40
15 CLEANING CHROME TRIM	40
16 SPARE PARTS.....	41

1 INTRODUCTION

The fittings covered by these instructions should be installed in accordance with the Water Regulations published in 1999*.

Ideal Standard strongly recommends that these fittings are installed by a professional fitter.

*A guide to the Water Supply (Water Fittings) Regulations 1999 and the Water Byelaws 2000, Scotland is published by WRAS (Water Regulations Advisory Scheme) Unit 13, Willow Road, Pen y Fan Industrial Estate, Crumlin, Gwent, NP11 4EG.

These thermostatic shower mixers are designed to be installed on normal UK low pressure storage tank fed systems, unvented high pressure systems, modulating instantaneous water heaters or modulating combination (combi) boilers. They are suitable for all pumped applications.

WATER REGULATIONS

Hot and cold water supply pressures must be reasonably balanced and from a common source - both from storage or both from a supply pipe. (IRN 101). The mixers will function within specification on unequal pressures up to a ratio of 5 : 1, but it is not recommended that the cold supply be connected to the rising main and hot to the tank fed supply as the pressure differential is likely to exceed the 5:1 ratio. (See table 1) The minimum pressure for correct operation is 0.1 bar (1m head). Pressure head is measured as the vertical distance between the bottom of the cold water storage tank which feeds the hot water system and the highest point on the shower spray plate. When installing with a shower pump the use of a secondary tapping from the cylinder is highly recommended.

The picture below shows the various methods of connecting the hot water pipe to the cylinder - the most preferred on the left and the least preferred on the right.

The fitting should be so installed as to be readily accessible for examination, repair, replacement or operation. (IRN 111).

The temperature of the hot water must not exceed 85°C but the installer's attention is drawn to code of practice BS 6700 which recommends that stored hot water should normally never exceed 65°C. For correct operation of the valve, a minimum of 55°C is required.

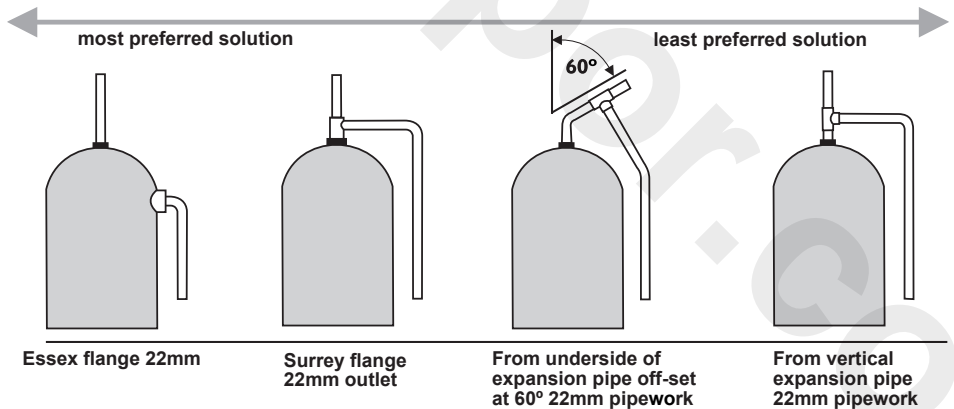

Figure 1
Preferred arrangements for cylinder tapping

In accordance to BSEN1111 & BSEN1287 the valve has approval for the following applications:
High and Low Pressure HP-S and LP-SE: A6453AA, A6456AA, A6455AA & A6458AA (shower valves)
High Pressure HP-S: A6454AA & A6457AA (shower mixers)

Note: If water supply is fed by gravity then supply pressures should be verified to ensure the conditions of use are appropriate for the valve.

2 SUPPLY CONDITIONS

Table 1 Conditions of use for Type 2 valves

Operating pressure range:	High Pressure	Low Pressure
Maximum static pressure	10 bar	10 bar
Flow pressure hot and cold	0.5 to 5.0 bar	0.1 to 1.0 bar
Hot supply temperature	55 to 65 °C	55 to 65 °C
Cold supply temperature	5 to 20 °C	5 to 20 °C
Temperature differential characteristic (TDC)	10 °C	10 °C

Valves operating outside of these conditions cannot guaranteed to perform correctly.

MODULATING COMBI BOILER

This thermostatic shower valve is designed for use with modulating combination boilers.

When installing on a modulating combination boiler it is sometimes possible for the interaction of a thermostatic valve with the combi to cause the boiler to cut out and cut in again, with the result that the water will become alternatively cold and hot. To overcome this, a 4 L/min flow regulator should be fitted upstream of the thermostatic valve. It should be fitted in any 15mm compression fitting in the dedicated cold supply pipe.

It is important to choose a compression fitting located in a position which is accessible after installation and it must be fitted the correct way round for the direction of flow. The regulator can be fitted in either the inlet or outlet side of the compression fitting. If fitting in an outlet side, ensure the o-ring is seated fully in the visible rebate around the edge of the regulator. Use the tip of a small screwdriver or similar to achieve this. Ensure the tail of the pipe is not fouling the regulator (shorten if required) and do up the compression fitting as normal. In a minority of cases, where the boiler is of a type which stores a small quantity of very hot water, it may also be necessary to fit a 4 l/min flow regulator in the hot supply.



↑
flow direction
through
flow regulator



These regulators (code A962570NU) can be obtained by contacting fastpart:

For more information on spare parts why not visit our spare website
www.fastpart-spares.co.uk

Isolation valves **MUST** be fitted to permit future maintenance of these products. Strainers are included with this product inside the check valve housing, see 5.8.

Isolation valves should be fitted as close as is practicable to the water supply inlets of the thermostatic shower valve, in an easily accessible location. See 10 for more details.

3 WATER REGULATIONS

CATEGORIES OF RISK

The water regulations published in 1999* take a new approach to backflow in that they look at different categories of risk. The installer must assess the risk from the various categories of fluid in adjacent appliances before determining the level of backflow protection required for a particular installation. Figures 3 & 4 describe the protection required in various installations.

CATEGORY 3 RISK

Water in a shower tray, basin or bathtub is considered to be a fluid category 3 risk which is a fluid which represents a slight health hazard if it were to find it's way back into the supply pipe. For this reason it must not be possible for any flexible shower head to be able to enter any adjacent washbasin, bath or shower tray unless appropriate protection is employed. (See Figure 3). If it is desired to allow the hand spray to be used inside say a bathtub or a basin it is essential that double check valves be fitted to the inlet on both hot and cold supplies to the thermostatic valve. Alternatively single check valves can be fitted at the inlets and an additional check valve should be fitted in the valve outlet. No check valves need be fitted if the hand spray is prevented from reaching closer than 25mm of the spill over level of any such fixture.

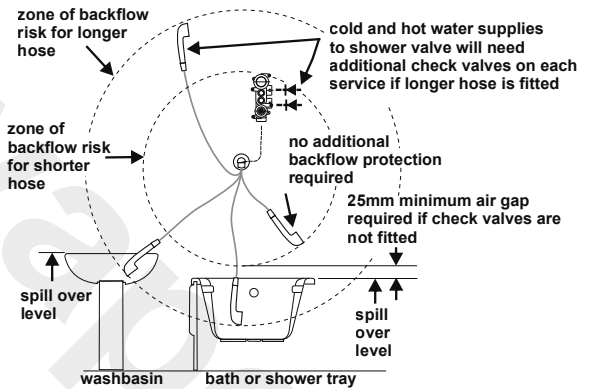

Fig. 3 Backflow risk from a fluid category 3

CATEGORY 5 RISK

Water in a Sink, WC or Bidet is considered to be a fluid category 5 risk which is a fluid which represents a serious health hazard if it were to find it's way back into the supply pipe. For this reason it must not be possible for any flexible shower head to be able to enter any adjacent Sink, WC or Bidet. If the flexible hose to be fitted could reach into any such vessel, the requirements to the system design are so onerous it is better not to fit a flexible. Rather, a fixed overhead showerhead should be considered. (See Figure 4). It will also be seen that this risk could change should the hose be taken out of the restraining device or should a longer replacement hose be fitted at a later date. Installers and householders are advised to take account of these factors when fitting replacement hoses. For pumped applications the pipe supplying the pump must not in addition supply an ascending spray bidet.

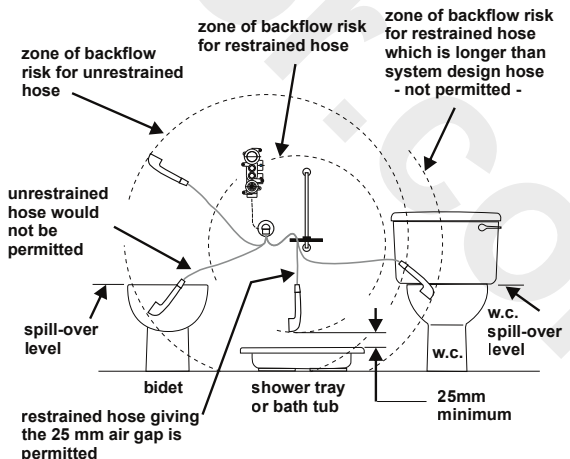

Fig. 4 Backflow risk from a fluid category 5

4.0 Pre-installation notes:

This installation instruction covers two main products types (both dual control):

- Products with integral on/off flow control: A6453AA & A6456AA.
The temperature and the flow rate of the water can be adjusted using the two control handles on the valve. The outlet device is normally a shower.
- Products with integral 3 function diverter: A6454AA A6455AA, A6457 & A6458AA.
The temperature of the water can be adjusted with the lower control handle on the valve. The upper handle is used to diverter the mixed water to either a shower device, a bath fill device or to switch off the water flow.

4.1 Overview of kits 1 & 2

For built-in products the installation is normally carried out in two stages:

During first-fix (kit-1) the valve-box is installed into the wall or panel.

During second-fix (kit-2) the chromed trim is fitted, usually after finishing (tiling) the wall.

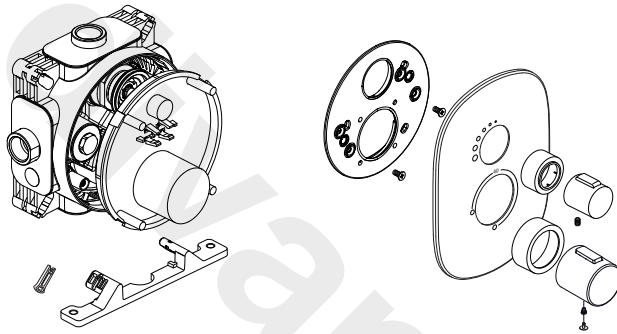

4.2 Kit-1 mounting depth control



IMPORTANT: For trouble-free installation of these built-in products the depth controls shown must be observed. Using a spirit level ensure valve-box is level in all 3 directions.

The valve-box is marked with MIN & MAX depth settings, the finished wall (after tiling) should lie between these markers as shown

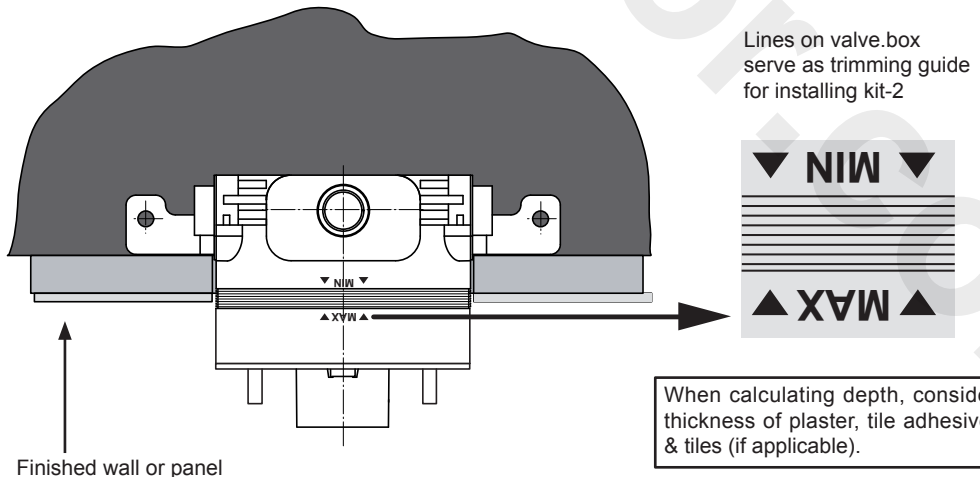

4.2 Kit-1 mounting depth control cont'

Effectively, the escutcheon plate can float 10mm, between the MIN & MAX (markers on the valve-box) thus permitting the mounting depth to vary by 10mm.

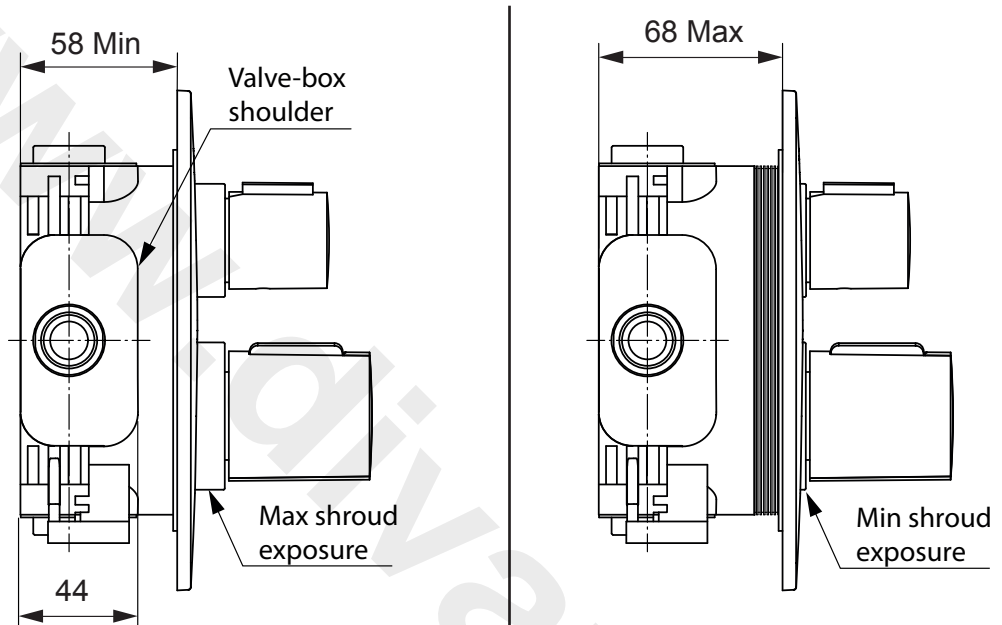

Cosmetically, when the escutcheon plate is furthest back (valve-box trimmed at MIN), this exposes more of the shroud diameters under the handle.

Conversely, when the escutcheon plate is furthest forward (valve-box trimmed at MAX), the shroud diameters under the handle are hardly noticeable.

Valve-box shoulder

The valve-box shoulders are created by the bosses surrounding the ports of the valve.

For example, if the valve-box is being panel mounted, the large diameter of the valve-box will pass through a hole in the panel & eventually stop against these shoulders.

See 5.7 for an example of how these shoulders can be used as a stop face.

4.3 Mounting options, quick overview

These products can be mounted using one (or a combination) of these 3 methods:

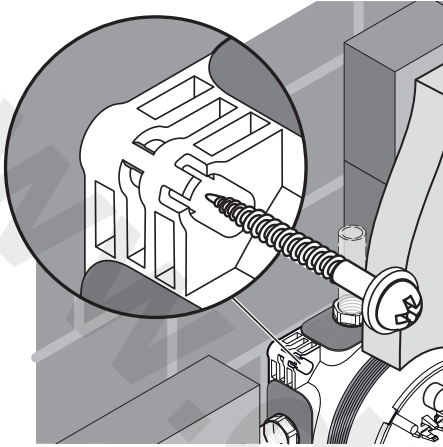

A. Directly through the valve-box using the 4 corner slots onto a solid surface. This method does not allow for any depth adjustment.

NOTE:
All fixing methods utilise the 4 slots positioned in the corners of the valve-box.

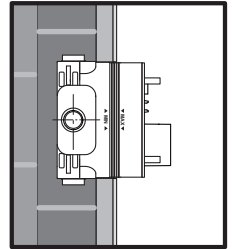

B. Using the mounting bracket supplied & attach to any one of 4 sides

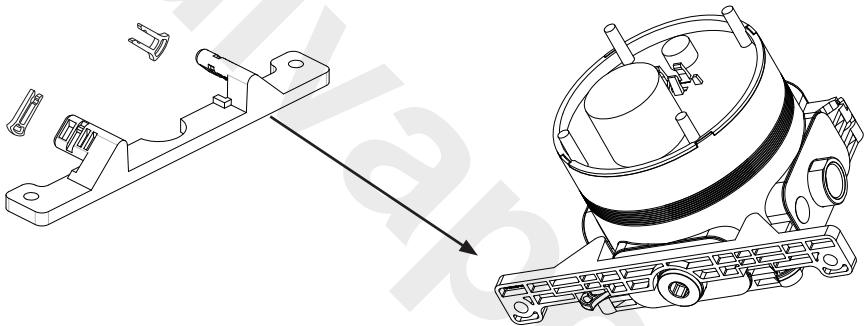

C. Using adjustable fixing legs (OPTIONAL) in either direction (x4 positions)

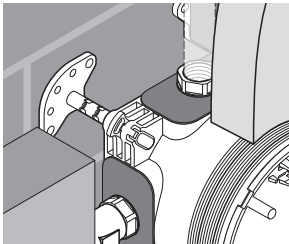

Legs with feet to rear:
Towards a brick wall.

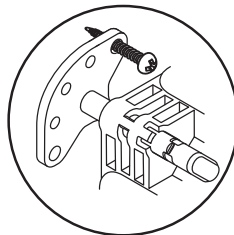

Legs with feet forward:
Towards a panel.

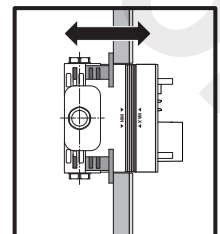
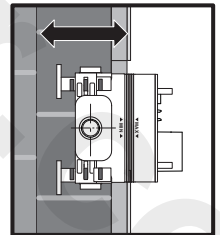

For adjustable leg details, see 5.3

4.4 Wall types, quick overview

These built-in products are designed for easy installation into most common wall types.

These low profile valves are especially suitable for slim duct systems where the minimum wall cavity depth can be as little as 44mm.

- Solid brick walls: See 5.4
Installer can chase-out brick work to create a cavity and then choose a mounting option. Alternatively, the installer may surface mount the valve onto a wall & then build a framework for a false partition or panelling system to conceal the valve-box & pipes.
- Pre-fabricated “pod” style bathrooms: See 5.5
The valve-box can easily be mounted from the rear of the pod wall during pod construction. This simplifies plumbing. The chromed trim can then be fitted from the front (from inside the pod) after tiling.
- Panel mounting: See 5.6
Valve-box can be panel mounted providing access is available from rear for fixing the valve-box to the panel & for attaching pipe-work.
- Partition walls: See 5.7
The valve-box can easily be mounted into a timber stud or metal frame construction wall. A versatile mounting bracket is supplied with this product which permits the valve-box to be anchored to a timber noggin or stud using any one of the four valve-box sides.

4.5 Valve-box orientation

It is **important** to maintain the valve-box orientation correct through out the installation. Otherwise the handle positions & escutcheon marking will be incorrect.

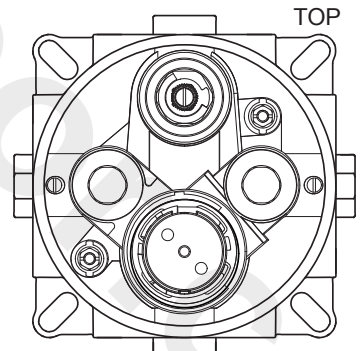
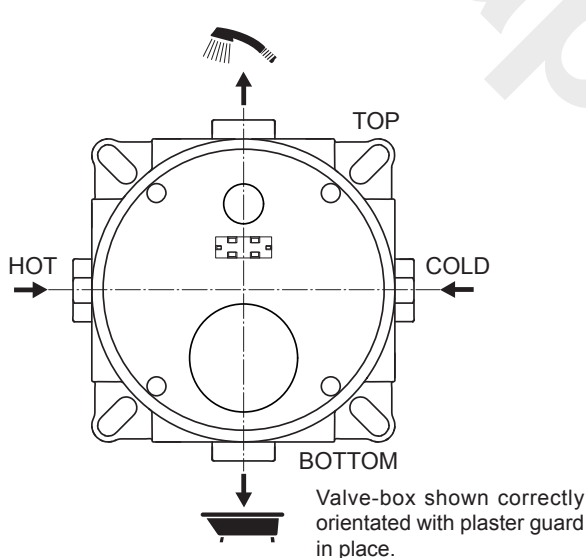

Ensure valve-box is level in all directions.

VALVE-BOX SHOULD NOT BE MOUNTED ONTO A HORIZONTAL SURFACE.

4.6 Kit-1 description

The built-in valve-box is supplied with a plaster guard (protective cover) fitted as shown. The plaster guard prevents debris entering into the valve-box during installation. Additionally, the plaster guard also serves as an aid to levelling the valve-box whilst mounting onto a wall or panel.



OBSERVE ORIENTATION OF VALVE-BOX, SEE 4.5.

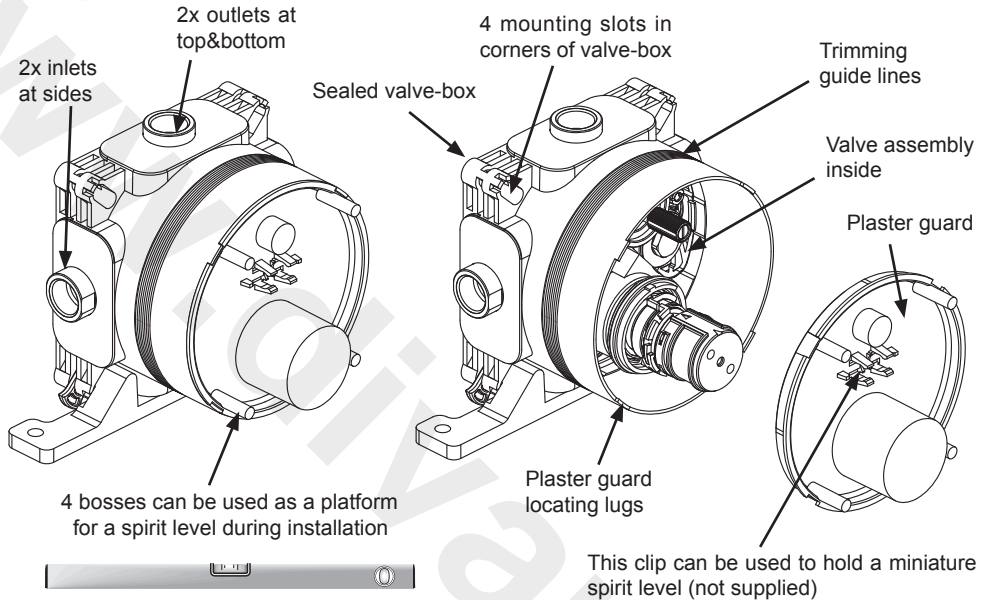

IMPORTANT: The valve-box is fitted with seals to prevent any water from leaking into the wall cavity. Therefore the inside of the valve-box should not be drilled otherwise water tightness will be lost. See 4.7.

ALWAYS UTILISE THE 4 SLOTS PROVIDED IN THE CORNERS OF THE VALVE-BOX FOR MOUNTING THESE PRODUCTS.

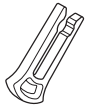

Latching clips: (pair supplied) are used to attach and secure the mounting bracket (& adjustable legs) to the valve-box by using a pair of corner slots. A mounting bracket is also supplied, see 4.3B.



Blanking plug: (threaded G1/2") to permit one mixed water outlet (either top or bottom) to be blanked-off (if it is not required). Use a 10mm Allen Key to drive plug. Plug is not supplied with diverter version of products

As mentioned in 5.1, use PTFE tape or similar to seal this plug into the body.

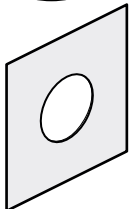

Fleece mat: (tiling aid) is supplied to help protect the wall cavity from water splashes which might penetrate from any gaps in the tiles around the valve-box. The mat should be placed over the valve-box and bonded to the wall using tile adhesive immediately prior to tiling (see 4.7).

The fleece mat is soft & flexible (water resistant) & will stretch around the valve-box diameter. For panel installations, the mat can be discarded & a suitable sealant should be used around the panel hole.

4.7 Valve-box sealing system

The built-in valve-box is designed with an extensive sealing system to prevent water penetration in two ways: Firstly, any trickles of water resulting from a minor leak inside the valve-box are prevented from entering into the wall cavity. Secondly, any water spray from the shower area is prevented from entering the valve-box.

Fleece mat: is bonded between the wall & the tiles. Mat prevents spay water from the shower entering into the wall cavity. See positioning illustration below:

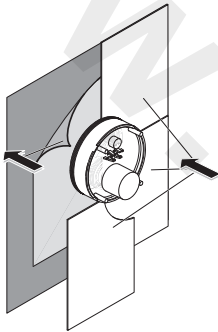

Lateral seals: All 4 pipe connection ports are reliably sealed all round. These seals prevent water trickles from minor leaks from the valve-box entering into the wall cavity.

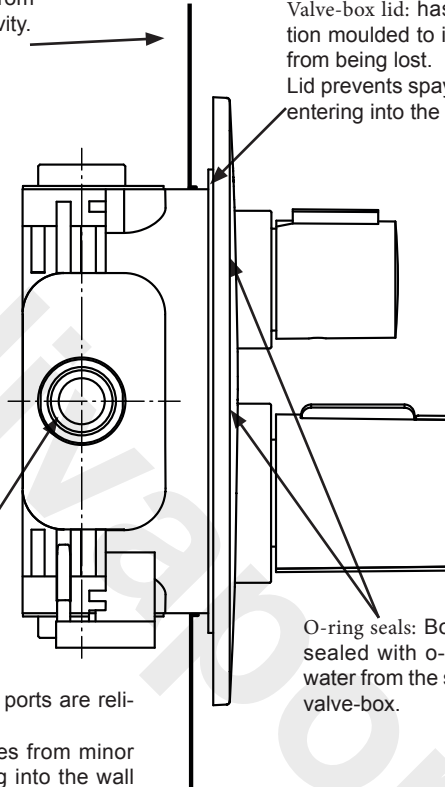

Valve-box lid: has precision seals injection moulded to it, thus preventing seals from being lost.

Lid prevents spay water from the shower entering into the valve-box.

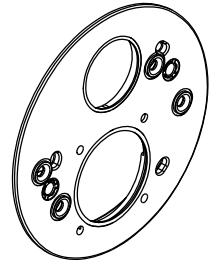

O-ring seals: Both handle shrouds are sealed with o-rings, preventing spay water from the shower entering into the valve-box.

Leak warning system: In the event of a leak occurring inside the valve-box, the accumulated water will begin to drip from the gap between the temperature handle & the shroud. If a drip occurs, this indicates there is a problem & the chrome trim kit should be removed & the leak fixed. This leak path is designed to freely permit drainage of water from inside the valve-box into the wet area of the bathroom (but prevent water from escaping into the wall cavity).

IMPORTANT: inside of valve-box should not be drilled otherwise water tightness will be lost.

5.0 Installation guide – kit.1

The thermostatic mixing valve must be installed in such a position that maintenance of the TMV and its valves and the commissioning and testing of the TMV can be undertaken.



IMPORTANT
BEFORE CONNECTION, FLUSH WATER THROUGH PIPEWORK TO REMOVE ALL DEBRIS ETC. WHICH COULD DAMAGE THE VALVE MECHANISM

NOTES:
These products are intended for installation into vertical walls. Installing into a horizontal surface is not recommended.
Isolating valves should be installed into the supply pipe-work to permit future servicing & maintenance.

5.1 Connecting pipe-work - preliminary

Some pipe-work can be connected to the valve-box prior to mounting into the wall.

- Apply PTFE tape or similar to inlet elbow threads.

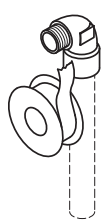

- Hold connector in valve-box stationary, using 25mm open ended spanner. Tighten elbow into connector

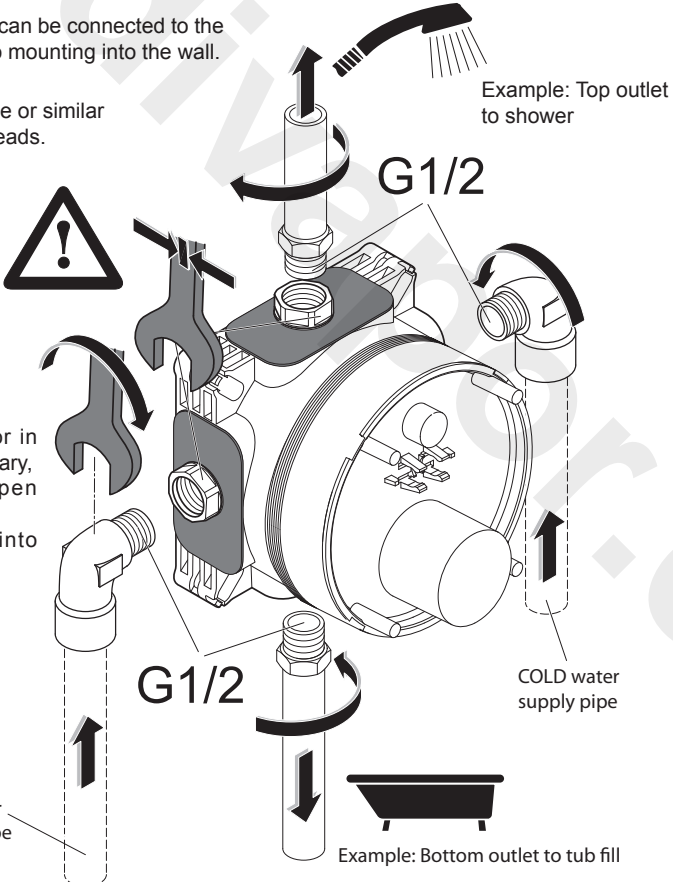

Alternatively, instead of PTFE tape, use a WRAS approved thread sealant; e.g.: Loctite 577 or Permabond A1044. DO NOT SOLDER NEAR VALVE-BOX.

Water supply pipes

Water supply pipes can be from any direction. Where supplies are provided from above, this normally permits better drain down of pipe-work. Pipe-work should be secured to the wall or panel using suitable fixing clips.



DO NOT apply heat near this product. Heat generated by soldering could damage plastic parts and seals

Suitable pipe connectors

All 4 connections to this product are threaded G1/2" female. Suitable pipe connectors can be obtained from all good plumbers merchants (not supplied).

Examples of a straight coupler and an elbow: 15mm compression to G1/2" male are shown here:

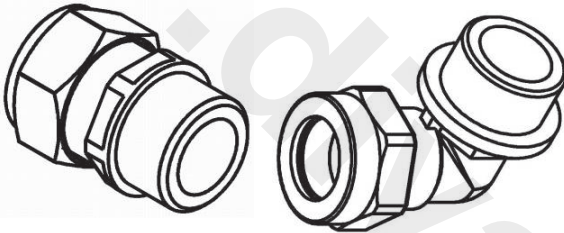

Remember: a blanking plug is supplied (see 4.6) & can be used on one outlet.
Use: elbows on the inlets & straight couplers on the outlets.

5.2 Mounting methods

With ref to 4.3, decide on the most appropriate mounting method for the wall type.
If using options B or C, attach the mounting bracket (or fixing legs) to the valve-box.

Using mounting bracket (method B).

To attach the mounting bracket to the valve-box:

First decide on which one of the four sides of the valve-box will be used for mounting.
Insert the two lobes of the bracket into an appropriate pair of slots in the valve-box.
If necessary, the bracket can be inserted into the valve-box from the rear.

Once the bracket is fully inserted into the valve-box, push the two latching clips home into their slots until they click in place.

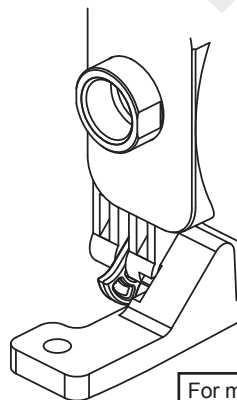
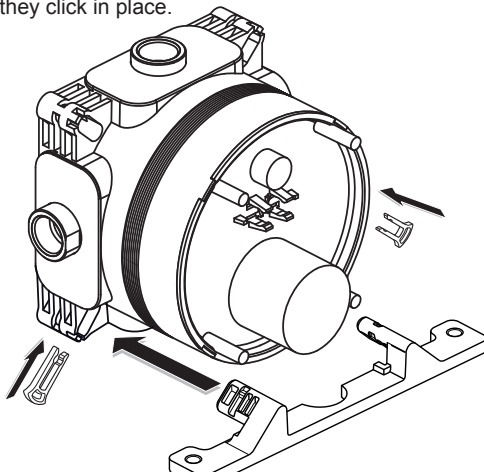

Valve-box with mounting bracket & latching clip fitted.

For mounting bracket dimensional information see page 2

Method B: cont.

Attaching the mounting bracket to either top or bottom of the valve-box permits the product to be secured to a timber noggin (horizontal) in a partition wall. Alternatively, attach the bracket to either side of the valve-box to utilise a nearby timber stud (vertical) for fixing.

5.3 Using OPTIONAL adjustable fixing legs (method C)

To attach the fixing legs to the valve-box:

For a solid wall insert each leg into a slot from the rear. Select a suitable depth by aligning a groove on the leg to the clip-slot then push the latching clip home until it clicks.

Similarly for panel mounting insert each leg into a slot from the front. Select suitable depth & secure all 4 legs with latching clips.

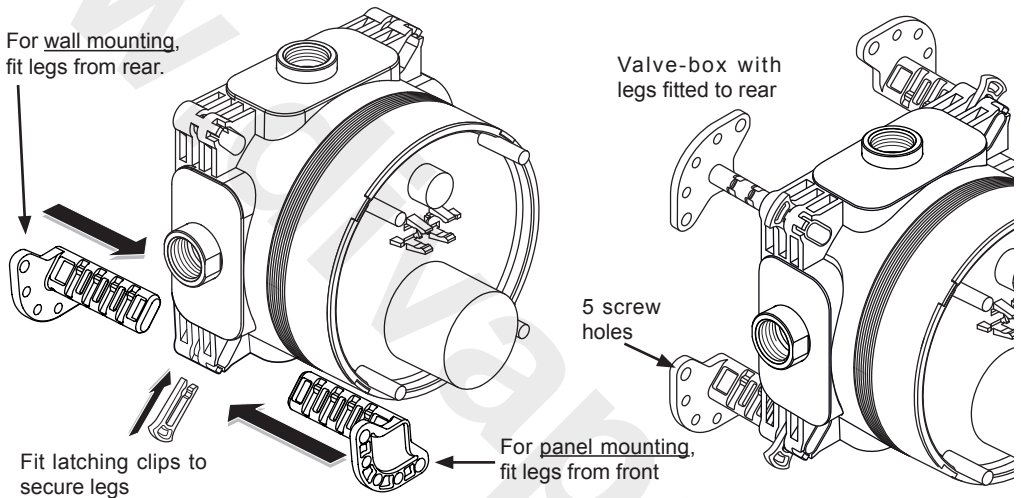

Note; If further depth adjustment is required, the latching clips can be easily be removed by pulling on the projecting lobe of the clip. Slide the leg along the slot until a more suitable leg-groove is visible, and then refit the latching clips to secure.

ADJUSTMENT NOTE: The fixing legs have 4 grooves permitting 4 depth settings. Ensure all 4 legs are secured at the same depth.

The legs should be orientated as shown in the previous illustration, with the 5 fixing holes outwards to permit screws to be easily fitted.

For leg dimensional information & orientation, see page 3.

NOTE: Adjustable legs are not supplied with these products. Contact fast-part to purchase a leg kit by quoting spares code: A963131NU. Each kit contains 4 adjustable legs and 4 latching clips.



For more information on spare parts why not visit our spares website
www.fastpart-spares.co.uk

5.4 Mounting valve-box into a solid wall

Before commencing, decide on which installation method to adopt from the two detailed below. Mark the wall at the desired location for the valve-box. Decide on preferred mounting option (see 4.3). Note: before mounting, it may be easier to fit pipe connectors to the valve-box (see 5.1).

CAVITY METHOD requires the installer to chase-out the brick-work to the required depth. Then mount the valve-box & pipe-work into this cavity. The cavity can then be closed-off for example with plaster board. Cut large hole in the covering plaster board to suit the valve-box diameter (see below).

FALSE-PARTITION METHOD requires the installer to mount the valve-box directly onto the wall, then build a false partition or use a panelling system in front of the wall to conceal the valve-box & pipe-work. The false wall can be just local to the valve area.

Cut large hole in the covering panel to suit the valve-box diameter (see below).

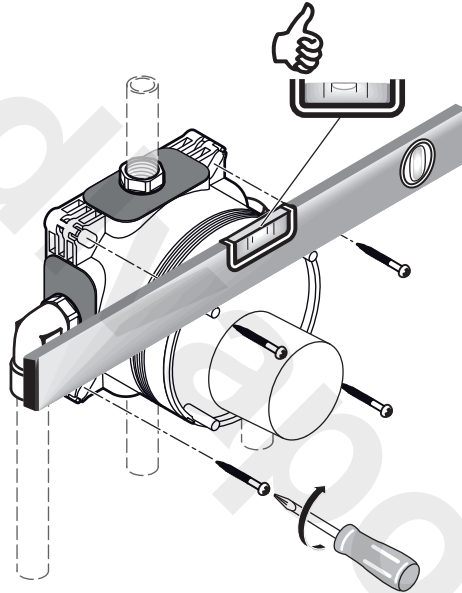

Use suitable supporting washers under the screw heads

Check level & valve-box orientation (see 4.5). Confirm valve-box is projecting correctly from the wall; such that the finished wall will fall between the depth markers (see 4.2).

For both methods, drill at least 4 fixing holes in the wall & fit suitable wall plugs for screw type being used. Ensure valve-box is securely attached to the wall.

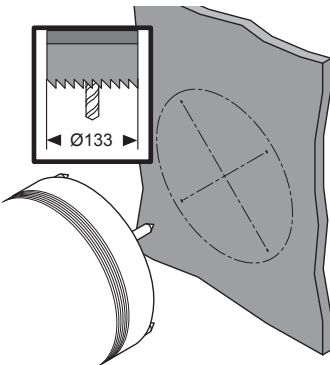

The large hole to be cut in the panel or plaster board should be $\text{Ø}133\text{mm}$ (5.1/4"), which permits some clearance around the valve-box diameter ($\text{Ø}129\text{mm}$)

ENSURE THIS HOLE IS ADEQUATELY SEALED. USE THE FLEECE MAT SUPPLIED WHEN TILING OR USE A SUITABLE SEALANT FOR PANEL INSTALLATIONS.



WARNING: Cavity should only be closed off when all pipe-work has been checked for leaks. Remember isolating valves must be installed in an easily accessible location

5.4 Mounting valve-box onto a solid wall, cont'

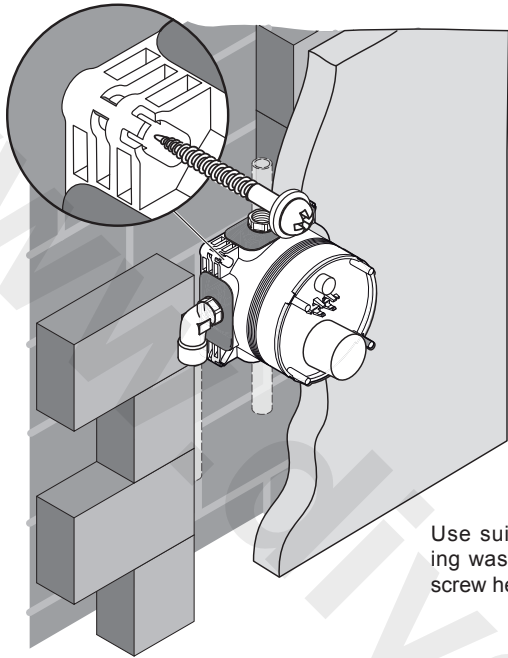

Mounting option A (direct) through the valve-box using the 4 corner slots

Note: using mounting option A, (direct) provides the shallowest cavity depth, but does not permit any depth adjustment.

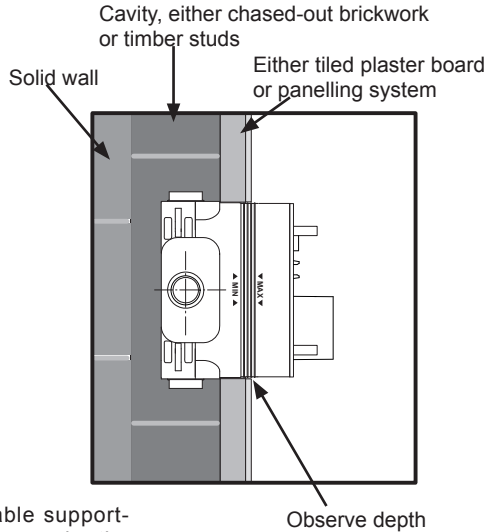

Use suitable supporting washers under the screw heads

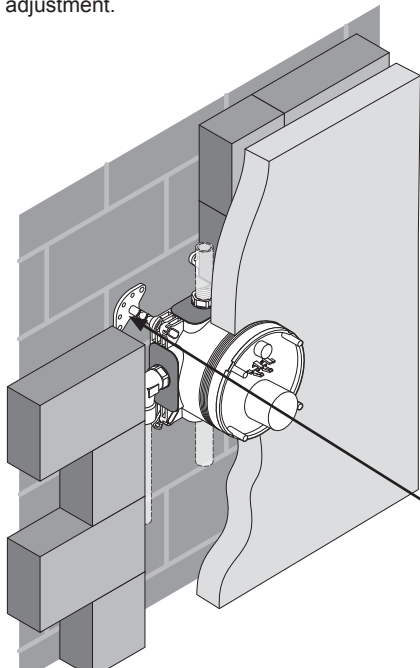

Mounting option C illustrated here using OPTIONAL adjustable fixing legs.

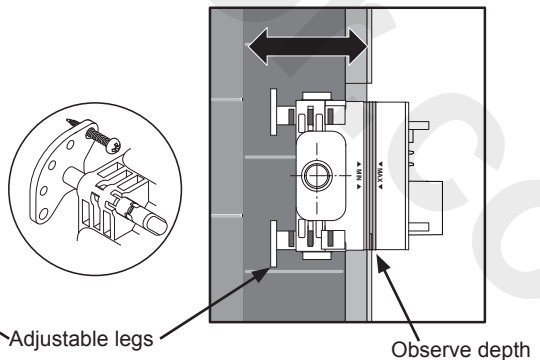

For adjustable leg details, see 5.3

5.5 Mounting valve-box into a pre-fabricated pod wall

These products can be installed into a modern pre-fabricated pod style bathroom.

The valve-box can be mounted into the pod wall from the rear during the pod construction. Note: before mounting, it may be easier to fit pipe connectors to the valve-box (see 5.1).

Typically, a pod wall is constructed with vertical steel members (40mm "U" section) set at 300mm centres. Framework is then lined internally with 15mm fire resistant plaster board. Decide on preferred mounting option (see 4.3).

BRACING BRACKET METHOD where the installer can design & fabricate a metal bracket to brace over two vertical members of the pod wall. The bracing bracket is normally bolted to the vertical members. The valve-box can then be bolted onto this bracket either directly using the 4 corner slots (M8 bolts max) or by using the **OPTIONAL** legs (M5 bolts max).

A large hole should be cut in the plasterboard (see 5.4) to permit diameter of valve-box to pass through. Check level & valve-box orientation (see 4.5). Confirm valve-box is projecting correctly inside pod; such that the finished wall will fall between the depth markers (see 4.2).

Mounting option A (direct) can be used to fix the valve box to the bracket using suitable fixing bolts (M8 max). Bolts can be fitted from the front or from the rear to secure the valve-box to the bracing bracket.

Use suitable supporting washers under the bolt heads if necessary. To ensure valve box is securely fastened to bracket, use at least 4 bolts.

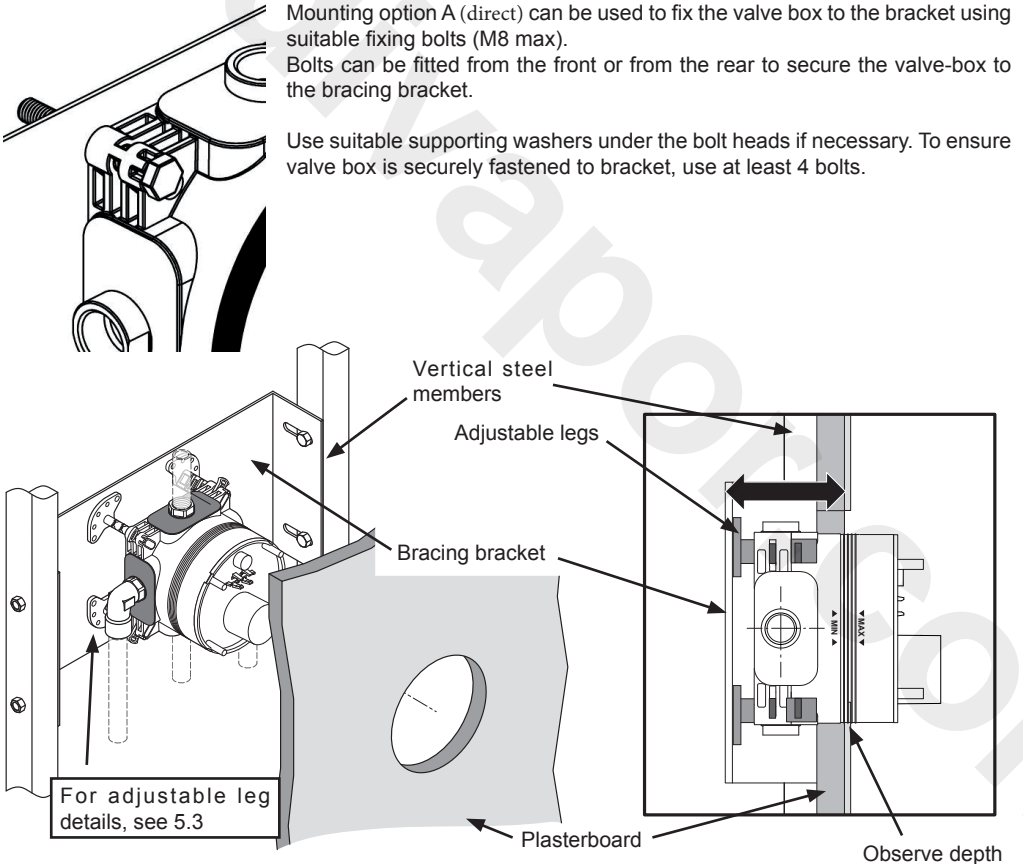

Mounting option C illustrated above using **OPTIONAL** adjustable fixing legs

5.6 Mounting valve-box into a panel

Recommended panel thickness should be in the range 14.5 to 26mm. Cut large hole in the panel (see 5.4) at the desired location for the valve-box. Decide on preferred mounting option (see 4.3). Two mounting methods are discussed below.

Note: before mounting, it may be easier to fit pipe connectors to valve-box (see 5.1).

DIRECT MOUNTING OPTION (A) can be used with long wood screws and suitable washers. Guide the valve-box into the large hole, until it stops against the rear of the panel. Check level & valve-box orientation (see 4.5). Confirm valve-box is projecting from the front of the panel between the min & max depth markers (see 4.2). Pack-out if necessary.

Fit a screw into each corner slot of the valve-box from the rear to secure to panel. Care should be taken to prevent screws drifting towards the large hole.

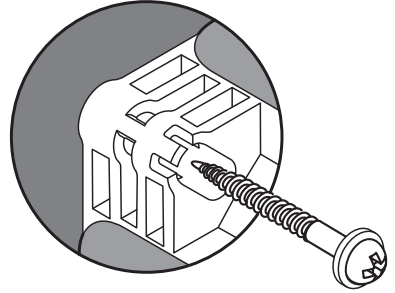

ADJUSTABLE LEGS OPTION (C) fit the OPTIONAL legs to the valve-box, from the front; to the desired depth (see 4.3C & 5.3). Guide the valve-box into the large hole, until the legs stop against the rear of the panel. Check level & valve-box orientation (see 4.5). Confirm valve-box is projecting from the front of the panel between the min & max depth markers (see 4.2). Adjust leg positions if necessary. Mount the valve-box to the panel using wood screws through the leg fixing holes

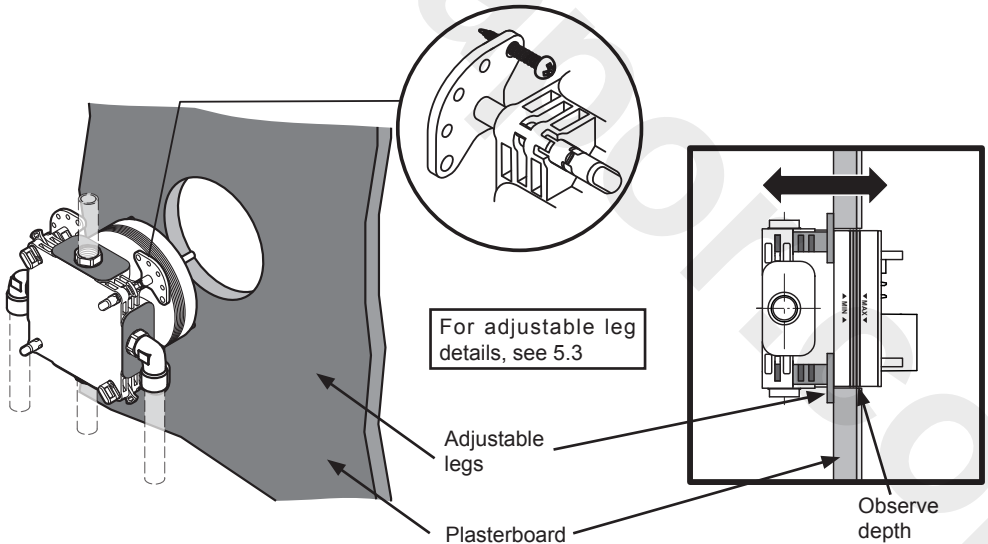

Mounting option C illustrated above using OPTIONAL adjustable fixing legs.

IMPORTANT: Ensure the panel is capable of supporting the valve-box securely with the screws being used. Check that the screw length will not penetrate through the front of the panel & spoil the visible surface.

5.7 Mounting valve-box into a timber stud wall

These products can be installed into a modern timber stud construction partition wall.

The mounting bracket supplied (option B) can be attached to any side of the valve-box (see 4.3 & 5.2). This enables the valve-box to be secured to either a timber stud (vertical on either side) or to a timber noggin (horizontal, below or above the valve-box).

Mounting bracket can be secured from in-front of the wall or from behind.

Alternatively, the valve-box can also be mounted directly using the corner slots.

For retrofit fit applications, an area of plaster board approximately 400x400 should be cut away and then replaced after installation. This is necessary to facilitate pipe connections. The framework may need to be adjusted to provide a means of fastening and supporting the product.

TIMBER STUD WALL framework is normally constructed using 75x50 (3"x2") rough sawn timbers, for larger walls 100x50 (4"x2") can be used. Stud centres spacing of 400 is used here in discussion. Note that 450 and 600 centres are also commonly used - this usually depends on the plaster board size being used. Plaster board thickness of 12.5 (1/2") is generally recommended.

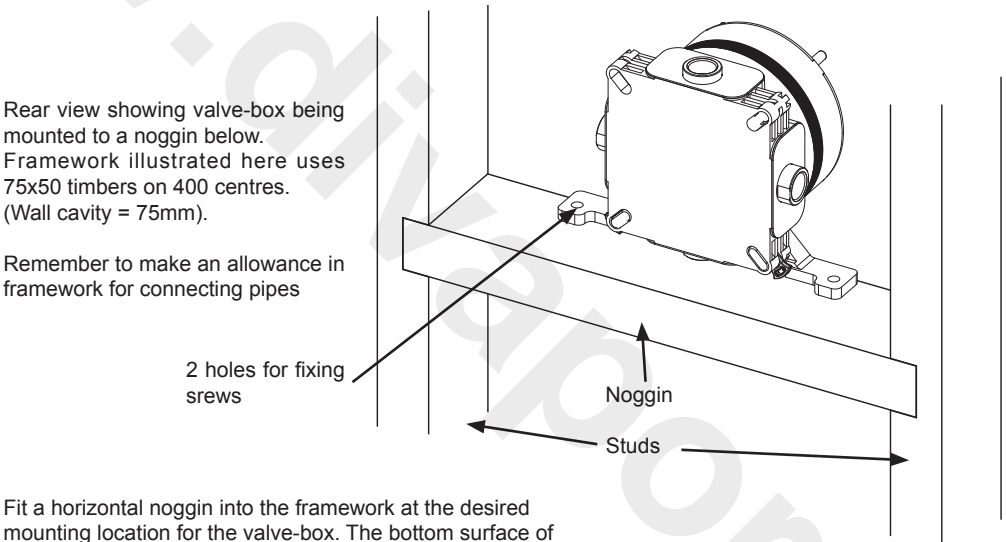

Fit a horizontal noggin into the framework at the desired mounting location for the valve-box. The bottom surface of the bracket is 75mm from the centre of the valve-box. Therefore, the top edge of the noggin should be positioned 75mm below the desired valve-box centre. Ensure noggin is level & secured.

Installation of valve-box will be easier if the front plaster board is fastened to the timber framework, but don't fasten the rear plasterboard until the installation is completed. Cut a large hole in the front plasterboard (see 5.4) at the desired location for the valve-box. Note: Before mounting, it may be easier to fit pipe connectors to the valve-box (see 5.1).

Guide the valve-box into the large hole until it stops against the back of the plasterboard. The mounting bracket should be sitting on the noggin. Check level & valve-box orientation (see 4.5). Confirm valve-box is projecting from the front of the plasterboard correctly; such that the finished wall will fall between the depth markers (see 4.2). The valve-box can be slid along the noggin until this depth is achieved. Fit two suitable wood screws through the bracket into the noggin to secure.

Using this method the min' wall cavity depth can be as little as 44mm.

5.7 Mounting valve-box into a timber stud wall, cont

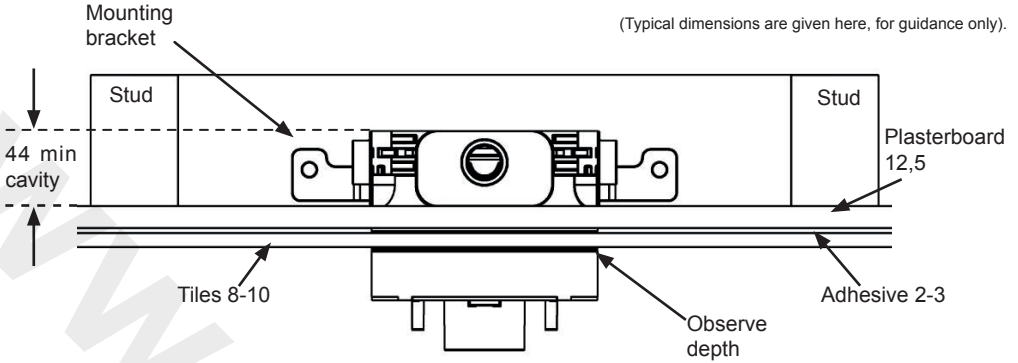

Plan view showing valve-box installed into partition wall, using mounting bracket.

Direct mounting

Alternatively, the valve-box can be mounted directly using the corner slots.

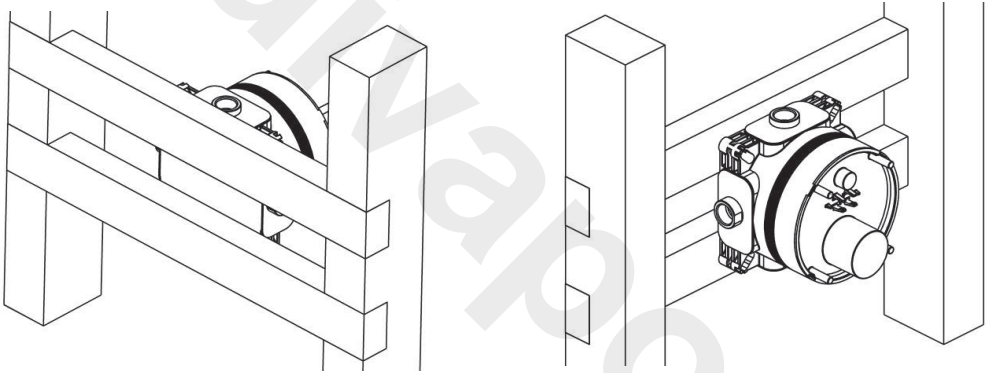

Illustrated above, valve-box being mounted onto a pair of slim noggins (30mm*) attached to the back of a pair of studs. Framework shown here uses 75x50 timbers on 400 centres. (Wall cavity = 75mm).

DIRECT MOUNTING OPTION (A) can be used with long wood screws and suitable washers. Position the valve-box onto the noggins. Check level & valve-box orientation (see 4.5). Confirm valve-box will project from the front plaster board between the min & max depth markers (see 4.2). Pack-out if necessary. Fit a screw into each corner slot of the valve-box from the front to secure to the framework.

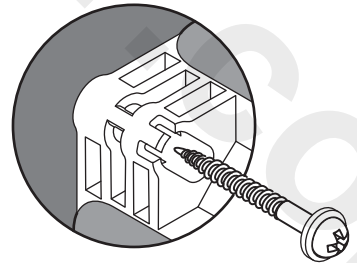

DEEP CAVITY WALLS

In some cases the partition wall may use timbers which are 100x50 or greater.

*Noggin thickness should be adjusted accordingly.

Greater wall cavity will also permit mounting by using adjustable legs kit. In principle, the method is same as shown in 5.5 (for solid wall). In this case the legs could be secured to a pair of noggins as shown above.

5.8 Completing pipe-work

The valve-box should now be securely mounted in the wall or panel at the desired location. If not already done so, fit connectors to the valve-box, see 5.1.

Remember one outlet can be closed off using the blanking plug (see 4.6).

Some preliminary pipe-work may already be attached to the valve-box.

Complete all plumbing to valve-box & to outlet device(s). Observe appropriate connections points, see 4.5.

For examples of pipe-work solutions see 5.9.

Remember to fit isolating valves in the supply pipes at an easily accessible location.

Before closing wall cavity, switch on the water supplies & check all pipe-work & connections for leaks.

Where appropriate, the wall can be finished with tiles.

Integral check valves

These products are fitted with integral check valves on both inlets to comply with water regulations. The check valve housings include strainers (filters). From time to time it may become necessary to clean debris from the check-valves & strainers.

These mechanisms should be cleaned carefully.

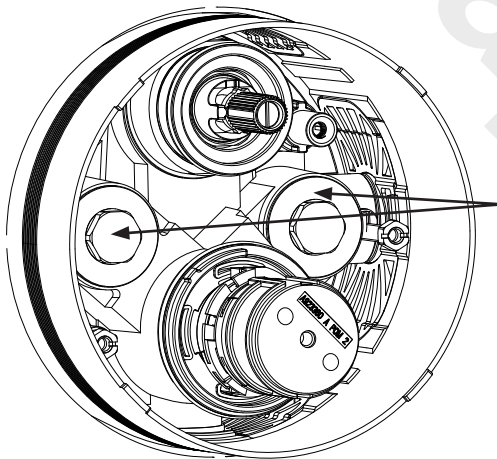
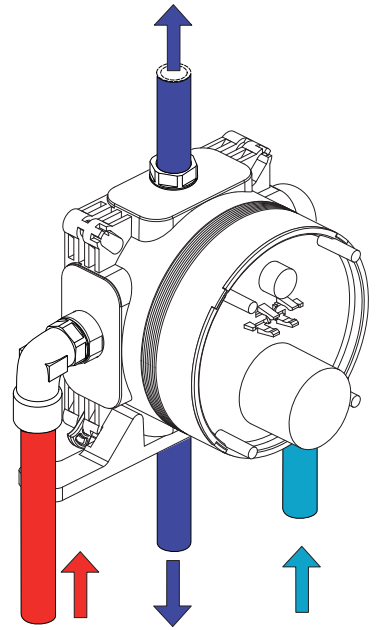

NOTE: The check valve housings also permit the supplying pipes to be flushed through the valve-box:

- Isolate the water supplies.
- Pull off plaster guard from the valve-box (if fitted).
- Remove the two check-valve housings (Use 15mm A/F socket).
- Place a vessel under the valve-box.
- Gently open the isolating valves allowing water to be discharged from the open areas.



Avoid dripping water onto panels, plaster board & floor. Upon completion of flushing, reverse the above procedure.

5.9 Examples of installations

This section illustrates just a few examples of how to run pipe-work to other bathroom accessories. Easybox Slim products can be used with many different combinations of shower kits & tub filling products. Contact our representatives or customer care for more details.

The illustrations shown should only be used as guidelines for possible solutions for a bathroom layout. Consult a professional plumber for advice on how to customise the best solution for your bathroom.

Basic installation example showing thermostatic shower valve with integrated "flow control" connected to a single outlet slide bar shower kit.

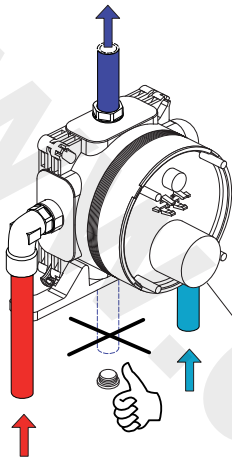

As illustrated, top outlet used & bottom outlet blanked off.

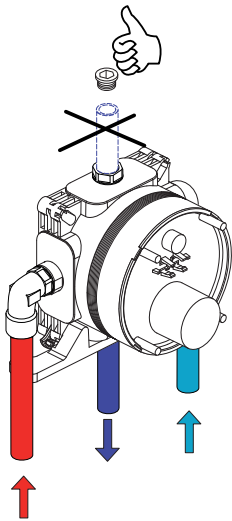

Alternative, bottom outlet used & top outlet blanked off.

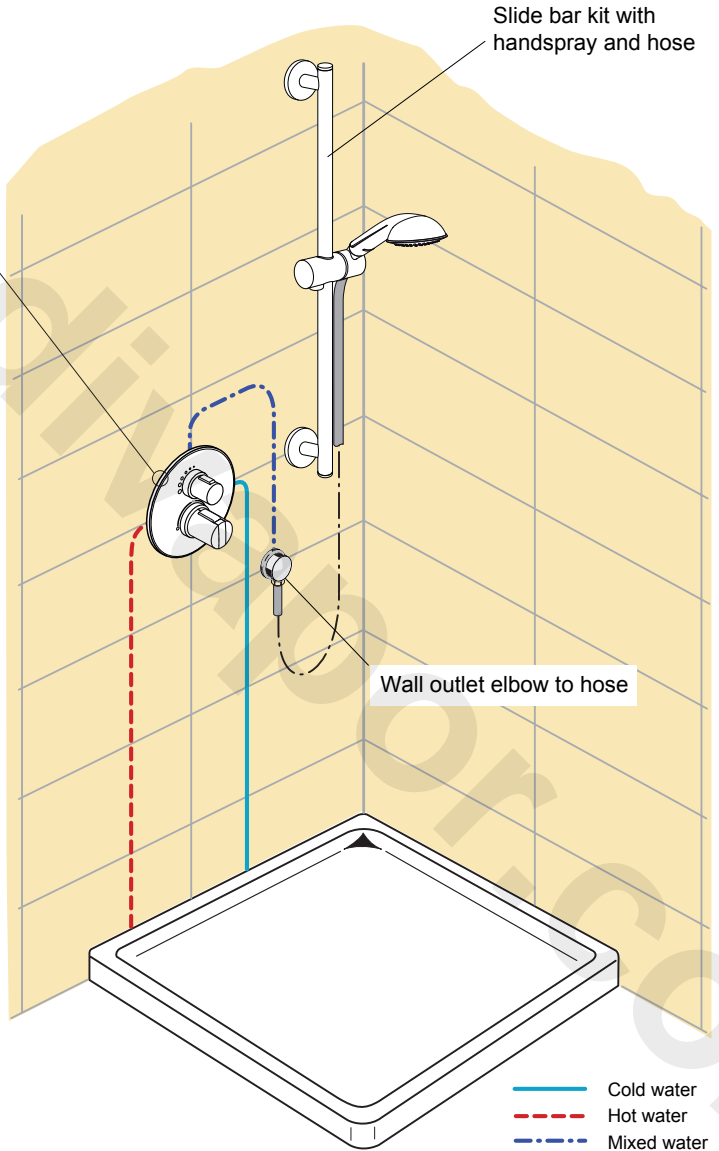

Two outlet example showing thermostatic shower valve with integrated “diverter” connected to slide bar shower kit & overhead shower.

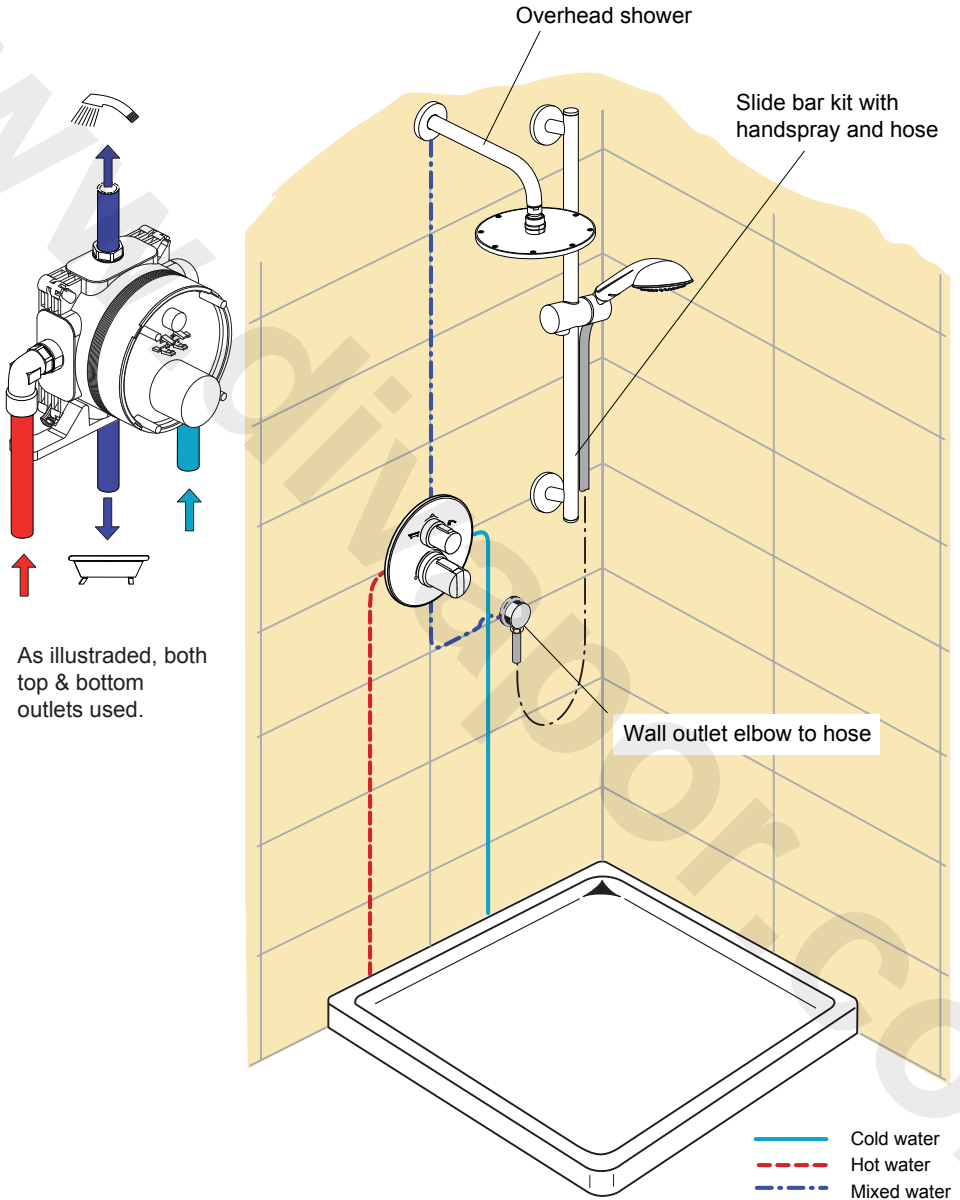

Two outlet example showing thermostatic shower valve with integrated "flow control" connected to a slide bar shower kit & overhead shower via external diverter. Diverter has one inlet & two outlets.

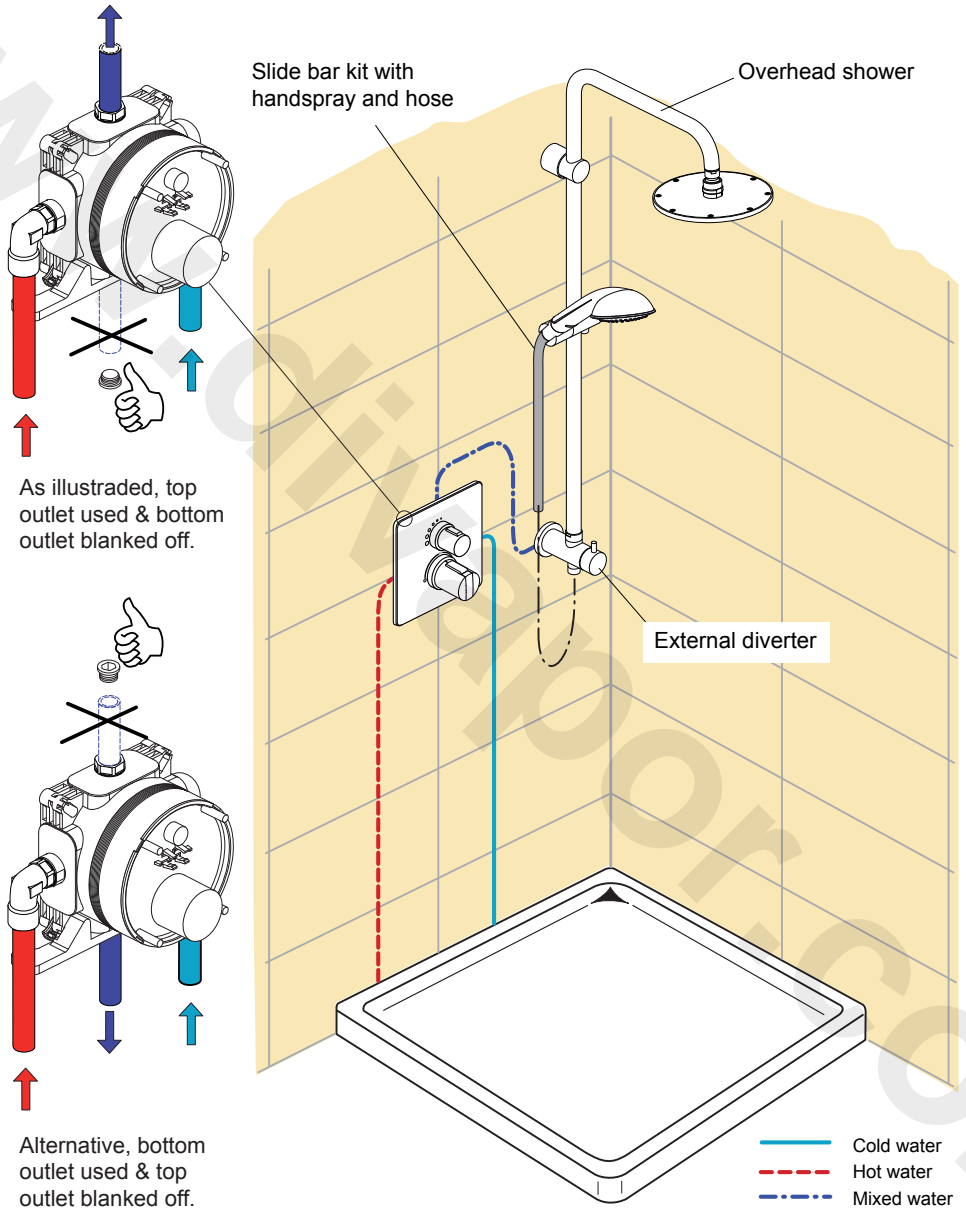

Three outlet example showing thermostatic shower valve with integrated “diverter” connected to a slide bar shower kit, overhead shower & body jets via an external diverter. Diverter has one inlet & two outlets.

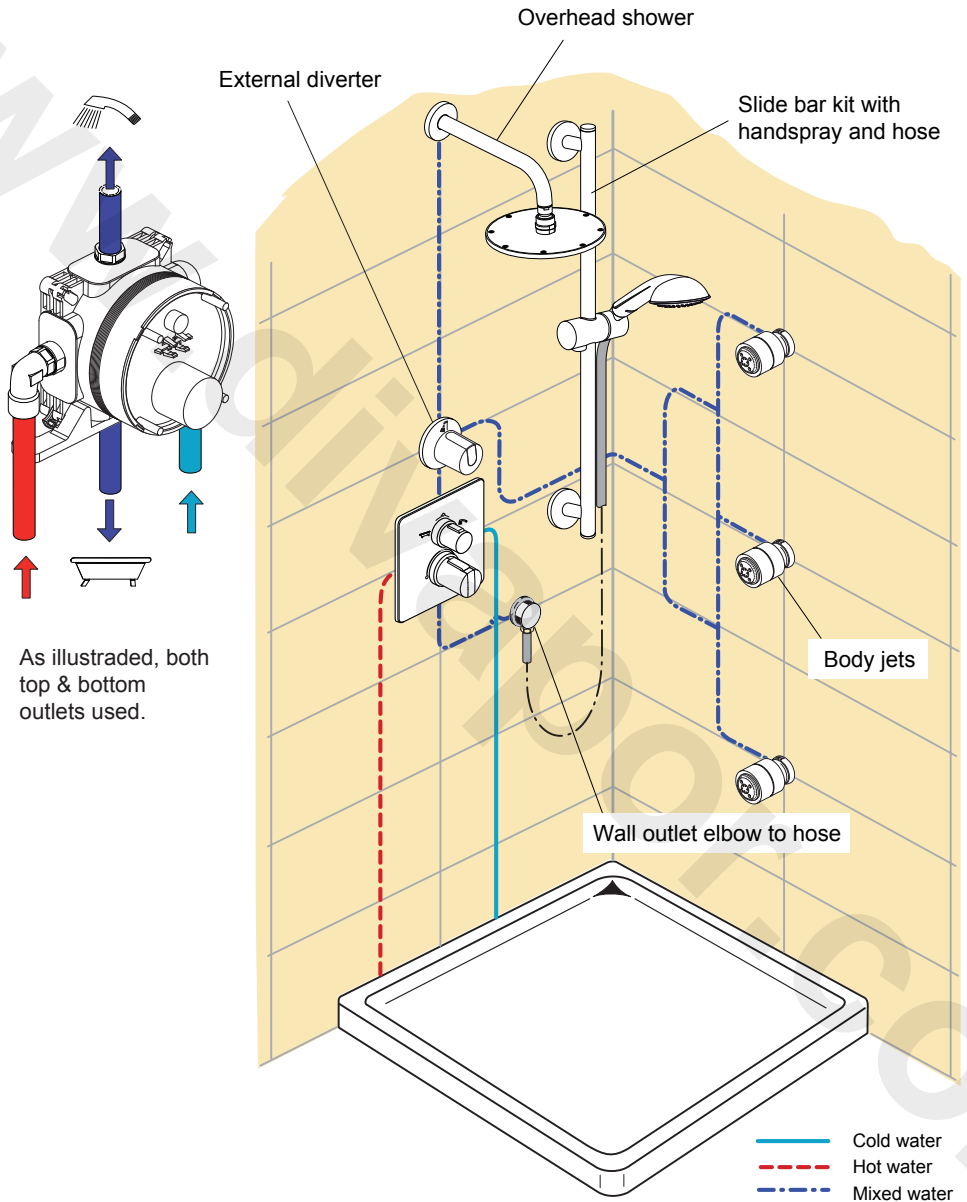

Three outlet example showing thermostatic shower valve with integrated “diverter” connected to a slide bar shower kit, overhead shower & tub fill. External diverter has one inlet & two outlets.

RECOMMENDATION:
Valve should be mounted at least 300mm above the bath rim.

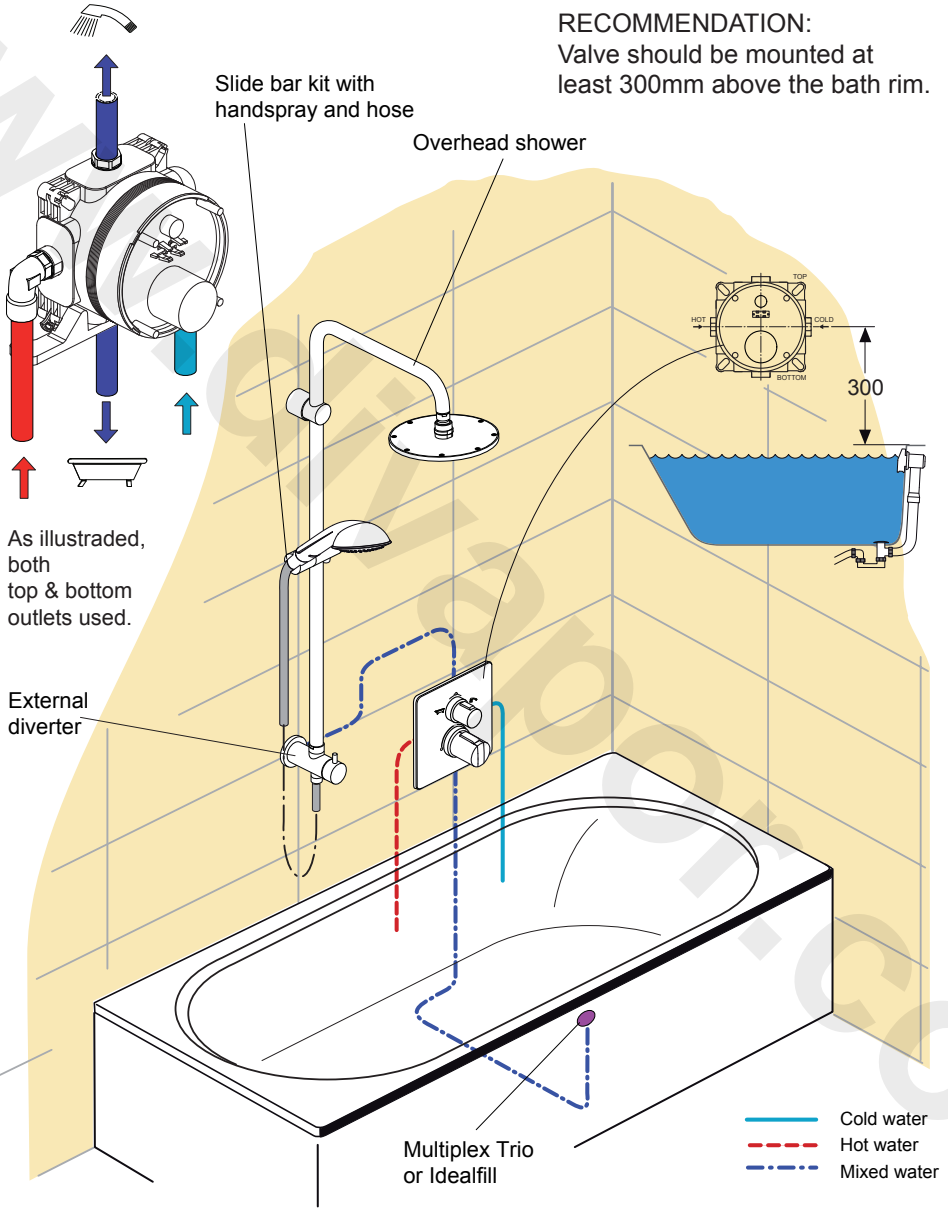

6.0 Preparation for chrome trim (kit-2)

Once the valve-box installation has been completed, & the wall is in a finished state (either tiled or panel finish) the plaster guard can be removed & valve-box must be trimmed as detailed below.

NOTES:

- It is important to use the fleece mat supplied to seal the wall around the valve-box if wall is being tiling (see 4.6 & 4.7).
- Wall tiles should be carefully trimmed to match the projecting valve-box diameter.
- Removal of trim kit will permit access to the valve cartridges for future maintenance. To do this, just reverse the following installation sequence.

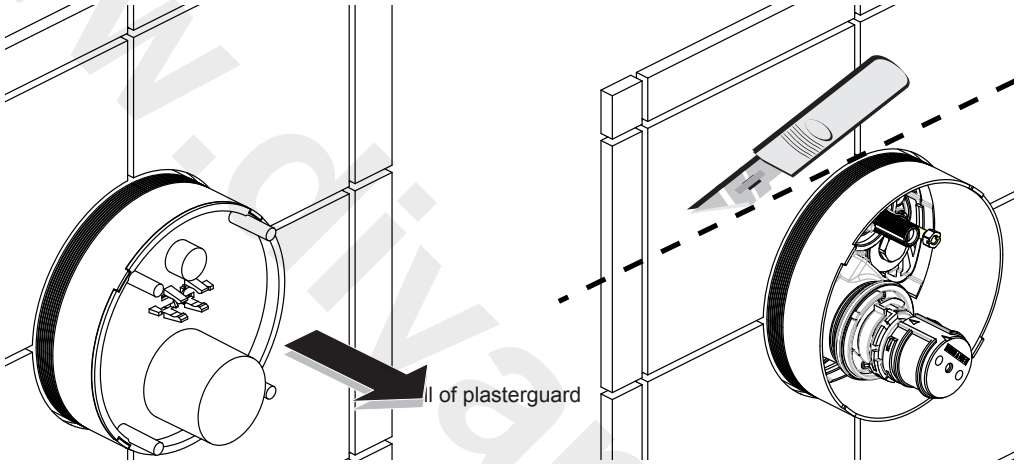

Illustrated above, valve-box projecting from the finished wall at the correct depth.

The plaster guard can now be removed to expose the valve assembly inside.

Use a sharp craft knife to carefully trim the valve-box diameter. Select a suitable line marked on the diameter as a trimming guide. The diameter should be trimmed level with the finished wall. Take care not to damage components inside the valve-box

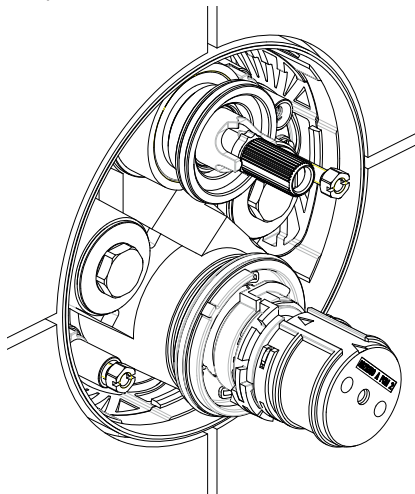

Illustrated on the left, the valve-box has been correctly trimmed. In this example, the product is the version with the integral "flow control".

The trim kit can now be fitted.

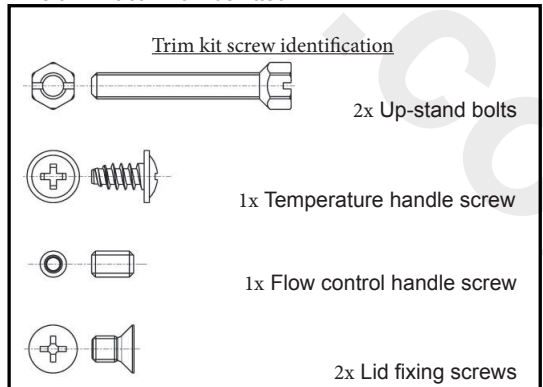

6.1 Description of chrome trim (kit-2)

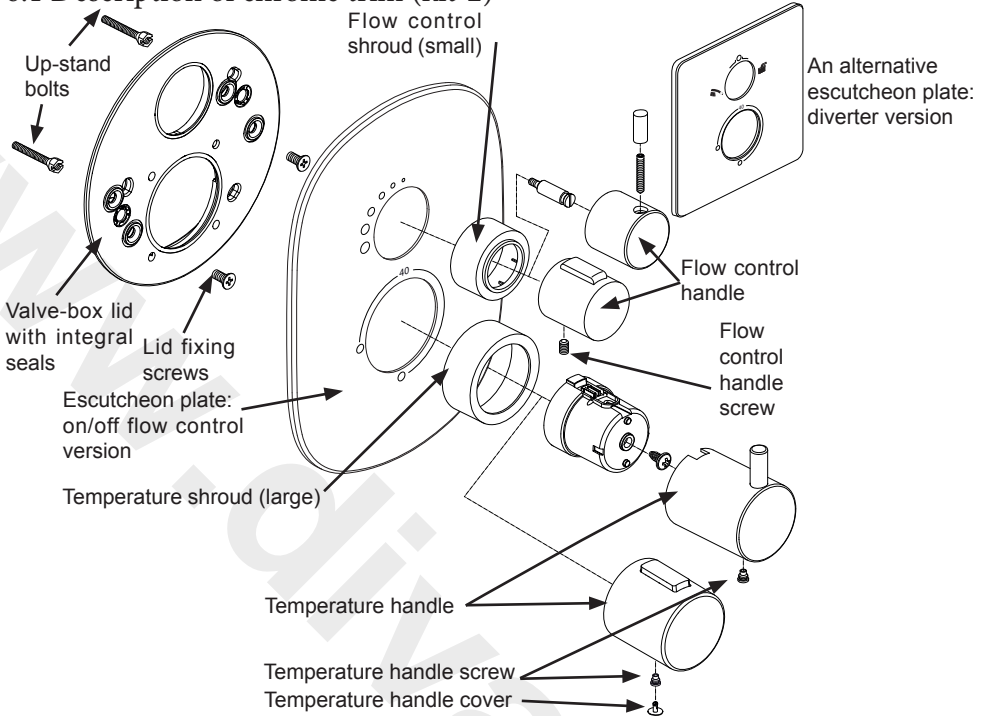

6.2 Installation of chrome trim (kit-2)

Ensure preparation work has been completed (see 6.0). The two up-stand bolts can be screwed into the valve body using a slotted screw driver at the positions shown. Do not screw these bolts right down, as they may require adjustment to accept the screws in the next step (for fixing the lid).

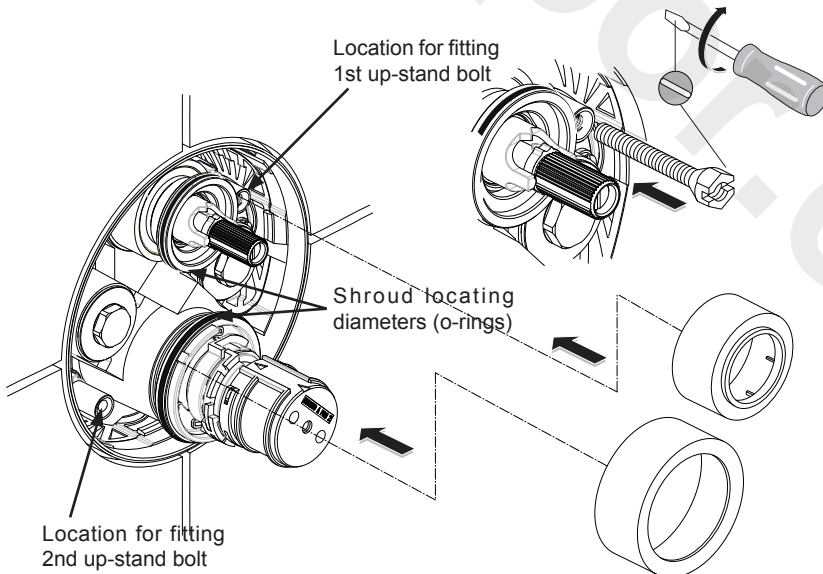

6.2 Installation of chrome trim (kit-2) cont'

As a guide, the top of the bolt can be kept level with the wall.
Note these special up-stand bolts are threaded internally & externally.

Fit both shrouds onto the appropriate housings. Apply a little soapy water to the o-rings that house the shrouds & then slide over. Note the shrouds will need to be adjusted at the end of the installation to close the gaps under the handles (by sliding along axis).

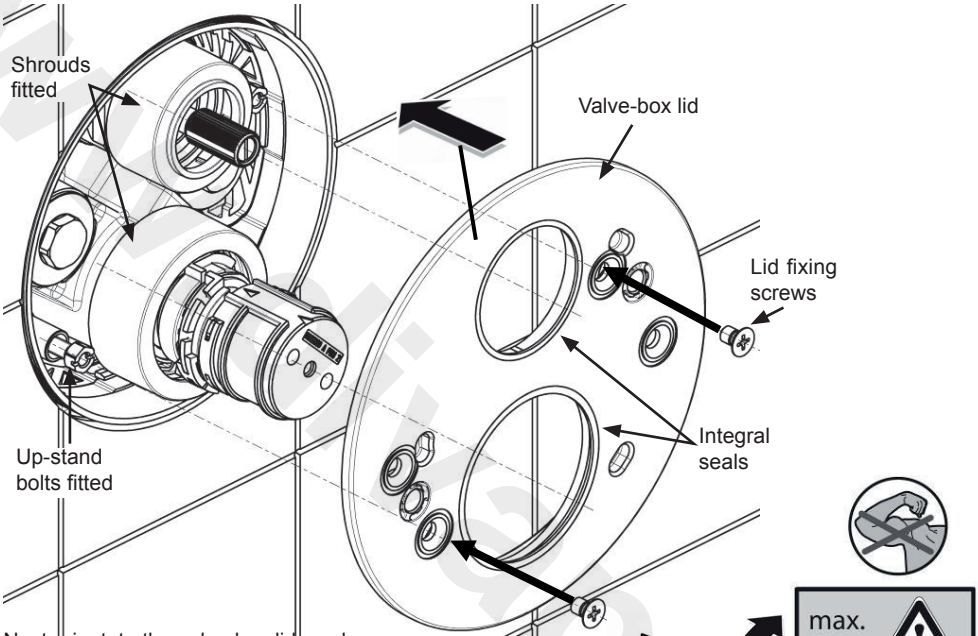

Next orientate the valve-box lid as shown. Align the lid bores to the shrouds & slide over. Gently push the lid onto the shrouds & the integral seals should make contact. Continue pushing the lid & the large corrugated lid seal should now engage into the valve-box bore. Push the lid further until the rear lid seal is firmly against the wall. Press the lid all around the edge to ensure that it is level with the wall.

Insert the lid fixing screws into the countersunk holes in the lid as shown. Fix the screws using a posi screw driver. **DO NOT OVER TIGHTEN.** The fixing screws should engage into the up-stand bolts, if not, remove the lid & adjust the height of the up-stand bolts.

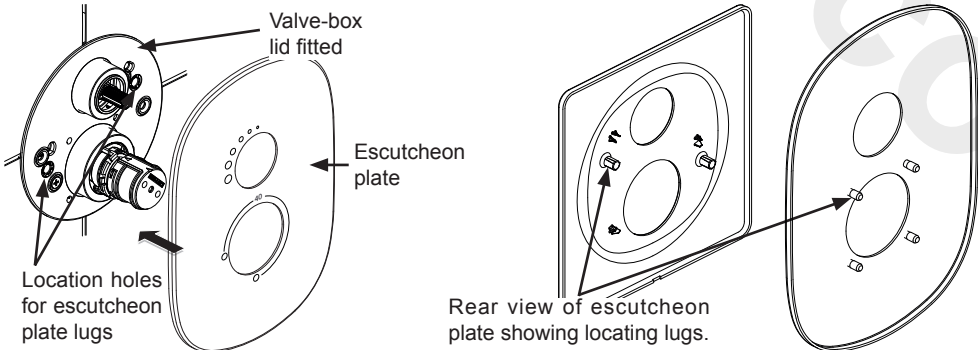
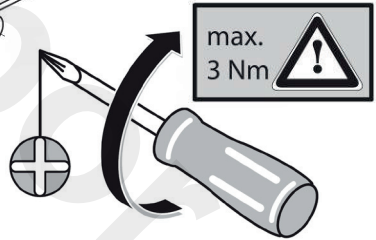

6.2 Installation of chrome trim (kit-2) cont'

With the valve-box lid secured, the escutcheon plate can be fitted. Orientate the escutcheon as shown. Guide the escutcheon over the two shrouds. The two locating lugs on the rear of the escutcheon should enter the holes in the valve-box lid. Push the escutcheon firmly until it makes contact with the wall. Press the escutcheon all around the edge to ensure that it is level with the wall. In the next step the handles can be fitted.

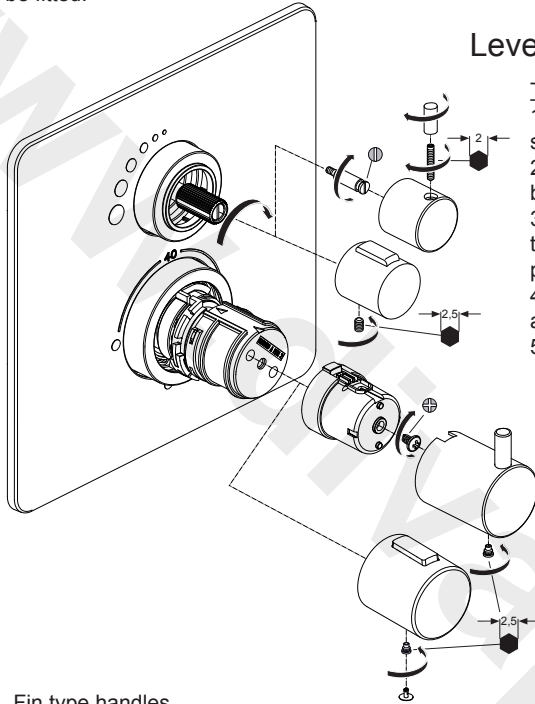

Lever peg type handles

To fit lever peg type flow control handle:

1. Remove the screw securing the black drive spline.
2. Fit the extended screw supplied to re-secure the black drive spline.
3. With the spline drive rotated fully clockwise, slide the handle onto spline drive (with peg hole to top position).
4. Fit the grub screw into the handle using 2mm hexagonal key.
5. Screw the peg onto the projecting grub screw.

To fit lever peg type temperature control handle:

1. Align the inner sleeve of the handle as shown & mentioned below. Secure with screw provided.
2. Slide outer handle onto the inner sleeve. Press firmly home.
3. Fit screw from underside of handle using 2.5mm hexagonal key.

Fin type handles

With the escutcheon in place, the flow control handle can be fitted. **IMPORTANT:** First rotate the black drive spline fully clockwise until it stops. Align the flow control handle to the 12'o-clock position (fin at top) & slide the handle onto the spindle & push firmly until it stops. The grub screw can be fitted from the underside of the handle using a 2.5mm hex key.

The temperature handle can now be fitted.

IMPORTANT: Check that the markers (pointers) on the handle carrier are in line as shown.

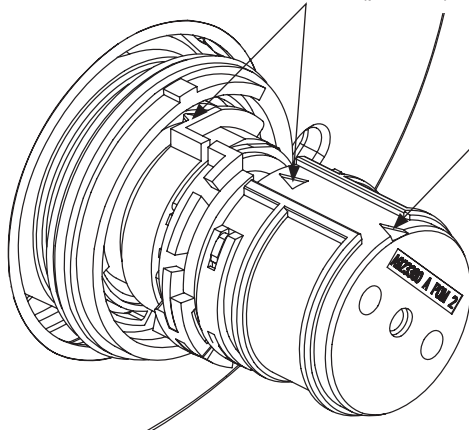

Orientate the temperature handle so that the button is at the top (as shown above). The location lug inside the handle should slide along the groove in the handle carrier. Push the handle along until it stops on the front face of the carrier.

Fit the handle screw using a posi screw driver.

To fit the handle cover, align cover to handle groove, slide along handle axis & snap into place.

Finally, the two shrouds can be pulled back closer towards the handles, to reduce any gap that might exist. Avoid shrouds contacting the handles otherwise they may generate a scraping noise in operation. Remember a small gap is required for the leak warning system, see 4.7.

6.2 Installation of chrome trim (kit-2) cont'

The completed installation is illustrated on the right.

6.3 Products with integral diverter

Products with an integral diverter should be installed in a similar way to the previously described method for the on/off flow control version. The only subtle difference is: before fixing the handle to the diverter spindle, ensure the spindle is positioned correctly. (Note the handle can be used to rotate the spindle if necessary).

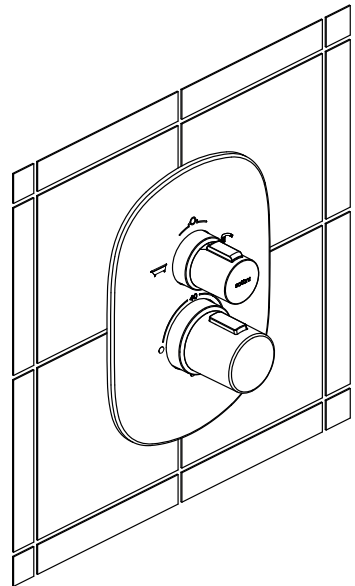

Diverter product has moulding on diverter spindle

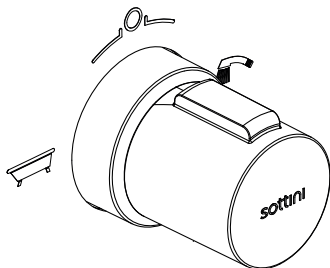
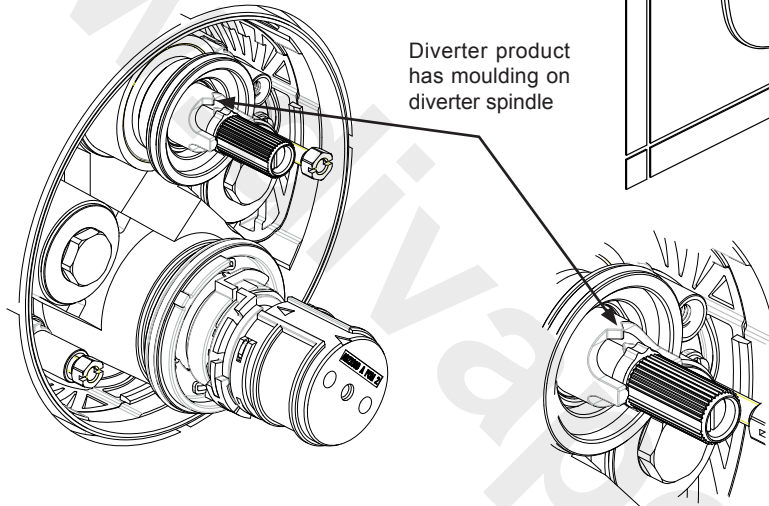

The diverter spindle rotates 180°, for example: clockwise from tub-fill to off (90°) & then to the shower position (90°). At each position the user can feel a soft click to indicate position. Rotate the diverter spindle such that the middle click is at the 12'o-clock position.

Orientate the diverter handle to the 12'o-clock position (fin at top) & slide the handle onto the spindle & push firmly until it stops. The grub screw can be fitted from the underside of the handle using a 2.5mm hex key.

7 Operation

A brief product description is given in 4.0. The operation of each handle is discussed in more detail here. Each handle has positional indicator (or a fin) which establishes the current setting of each control.

IMPORTANT NOTE: do not force handles beyond the ranges specified, otherwise this may result in damage to both valves & handles.

7.0 Operation cont'

Temperature control handle: Is either fin type or lever peg type. This handle is the lower control (large diameter) surrounded by red & blue circular segments marked on the escutcheon plate.

This handle controls the temperature of the water flowing from the built-in valve. The positional marker (or fin) is shown below parked at the 40° symbol. At this temperature “stop” position, mixed water will be delivered up-to about 40°C

Rotating the handle clockwise from this 40 (°C) symbol will reduce the temperature of the water. The handle movement will stop near the coldest “blue dot” marker (about 180° rotation).

To obtain higher water temperature, (from this 40 symbol position) press the button on the handle & then rotate the handle anti-clockwise. This effectively overrides the temperature stop. The handle movement will stop near the hottest “red dot” marker (about 90° rotation).

For further details on temperature adjustment see 8. (Note: total handle rotation is about 270°)

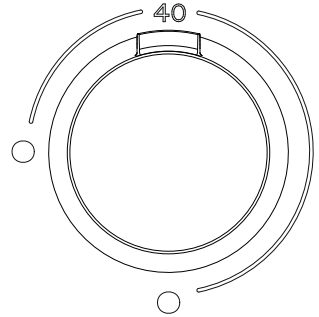

NOTE: Bathing & showering in temperatures exceeding 40°C can be harmful to your health

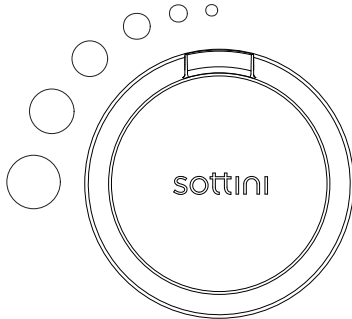

On/off flow control handle: is specific to certain product codes & is the upper control. This handle controls the volume of water flowing from the built-in valve. The escutcheon plate is marked with six symbolic circles which increase in size (anti-clockwise).

When the positional marker (or fin) on the handle is vertical (parked position, shown on left) the flow is switched off, indicated by the smallest circle symbol.

Rotating the handle 90° anti-clockwise, will give maximum flow as indicated by the largest circle symbol.

This handle will only rotate a quarter of a turn.

3 function diverter control handle: is specific to certain product codes & is the upper control. The escutcheon plate is marked around the handle area with symbols.

When the positional marker (or fin) on the handle is vertical at “O” (parked position, shown on right) the flow is switched off.

The other two symbols represent the outlet devices to which the water flowing from the built-in valve can be directed. The positional indicator (or fin) shows which outlet device is currently selected.

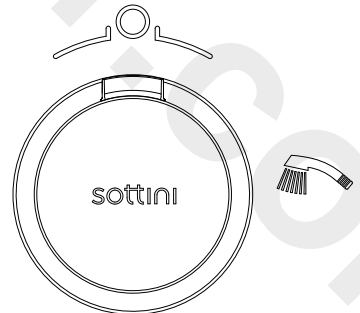

The left symbol represents tub-fill & will direct water to the bottom outlet, see 4.5.

Similarly, the right symbol represents shower & will direct water to the top outlet.

The symbols are spaced at 90° intervals. At each position the user can feel a soft click to indicate position. Total handle rotation is about 180°. The diverter permits one outlet to be opened at any one time, the second outlet will be closed.

8 Maximum temperature stop

The water temperature up to the stop button on the handle is set at 40°C.

The maximum mixed water temperature (achieved by overriding the stop button on the handle) is factory set at 43°C.

To change this temperature, remove the temperature control handle, see 6.2.

Remove the temperature limit stop (black H-shaped plastic part) and reinsert it in the appropriate recess on the handle carrier. Four different settings are possible: 40°C, 43°C, 45°C & 50°C

At last refit the temperature handle again.

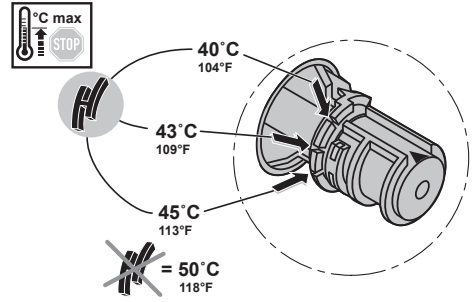

IMPORTANT NOTE. Settings of 45°C & 50°C are not recommended for showering. See section 10.1 for safe & comfortable bathing temperatures

9 Calibration of thermostat

In the event of the thermostatic cartridge requiring re-calibration the following procedure should undertaken:

1. Remove temperature control handle, see 6.2.
2. Slide out the red "U" piece (b) exposing temperature control mechanism (d).
3. Turn on the shower, position a thermometer in the running water and when the temperature settles, rotate the temperature control mechanism until 40°C is achieved.
4. Reconnect the handle carrier (e) ensuring the arrow guide (c) is at 12 o'clock and refit the red "U" piece (b).
5. Reconnect the handle to the carrier.

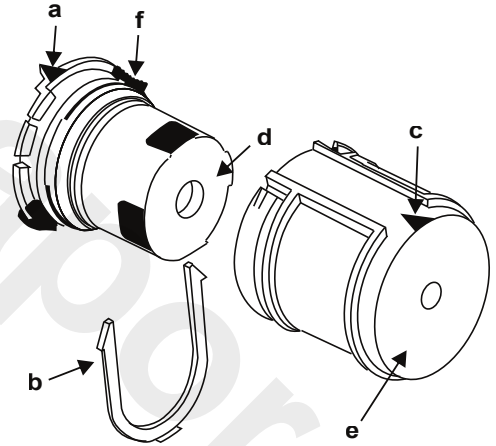

10.0 Isolating valves & Maintenance

In-line isolation valves **MUST** be fitted to permit future maintenance of these products. Strainers are included with this product inside the check valve housing, see 5.8.

Isolation valve should be fitted as close as is practicable to the water supply inlets of the thermostatic shower valve, in an easily accessible location.

Both water supplies must be isolated before commencing any servicing work on these products. Key working parts within the valve are in the form of replaceable cartridges. To access these remove the trim kit, see 6.2. Handle chrome parts carefully to prevent damage.

10.1 Commissioning & periodic checks.

The following procedures should be carried out after installation and every 12 months after to ensure that the valve is functioning correctly.

Check that:

1. The application of the thermostatic valve matches the approved designation.
2. The supply pressures are within the recommended range for the application.
3. The supply temperatures are within the permitted range for the application and comply with the guidance for prevention of Legionella.
4. The mixed temperature is as required for the application.

Record:

5. Each hot and cold supply. (Make a note of the measuring device used).
6. The mixed water temperature at the outlet device.

Isolate:

7. The cold supply to the mixing valve and record the mixed water temperature after about 5 seconds.

The temperature should not exceed the value given in the table (2) below.

Table.2. A guide to maximum temperature sets.

Application	Mixed water temperature	Permitted maximum temperature rise during site testing
Shower	41°C	43°C
Bath (tub fill)	43°C	45°C

Note: 46°C is the maximum mixed water temperature from a bath tap. The maximum temperature takes account of the allowable temperature tolerances inherent thermostatic mixing valves and temperature loss in metal baths. It is not a safe bathing temperature for adults and children.

The British Burns Association recommends 37°C-37.5°C as a comfortable bathing temperature for Children. In premises covered by the Care Standards Act 2000, the maximum mixed water temperature is 43°C

10.2 Frequency of regular servicing

The purpose of servicing regularly is to monitor the performance of changes in system and valve set up. This may require the need to adjust either the supply system or the valve. The product should be checked and tested 12 months after commissioning.

Firstly measure the water temperature at the shower outlet.

Carry out the cold water supply isolation test by isolating the cold water supply to the TMV, wait for 5 seconds if water is still flowing check that the temperature is below 45°C. If there is no significant change to the set outlet temperature (+/-2°C or less change from the original settings) and the fail-safe shut off is functioning, then the valve is working correctly and no further service work is required.

Notes:

A residual flow is permitted during the commissioning or the annual verification (cold water supply isolation test), then this is acceptable providing the water temperature is no more than 2°C above the designated outlet temperature.

Temperature readings should be taken at the normal flow rate after allowing for the system to stabilize.

The sensing part of the thermometer probe must be fully submerged in the water that is to be tested.

Any TMV that has been adjusted or serviced must be re-commissioned and retested in accordance with the instructions detailed above.

11 Thermostatic cartridge replacement

The thermostatic cartridge seldom fails and the possibility of blocked filters should be investigated before contemplating replacing it. Small particles of water borne debris may still find their way past the strainers and onto the filter screens on the thermostatic cartridge. These should be cleaned and re-fitted, see below.

To replace the thermostatic cartridge:

ISOLATE WATER SUPPLIES FIRST, drain down the pipe work as much as possible.

1. Prise out the handle cover (L-shaped) see 6.2.
2. Remove handle screw.
3. Pull off the temperature control handle.
4. To remove the temperature handle carrier (grey plastic moulding), slide the black serrated lever clockwise and pull off. This will expose some of the thermostatic cartridge.
5. Gently pull off the chromed shroud. The plastic moulding that supports the shroud may slide off with the shroud, if not, pull this moulding off too. This will expose the remainder of the thermostatic cartridge. The moulding should have two o-rings fitted.

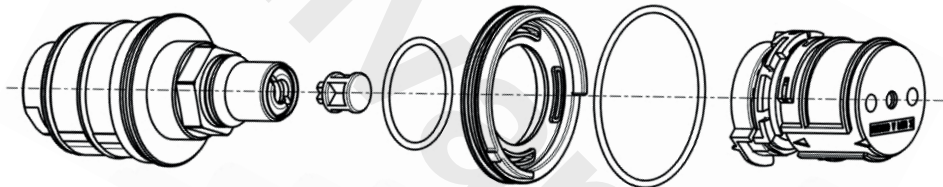
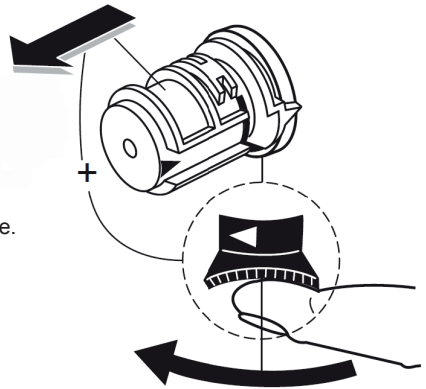

6. Unscrew cartridge with a 24mm A/F deep socket, expect some trapped water to escape. Replace the cartridge if necessary. When refitting cartridge, do not over tighten, hand tighten the first few threads, maximum torque 16Nm. ENSURE PARTS ARE REASSEMBLED IN THE CORRECT SEQUENCE.

Refer to 6.2 for assembling handle.

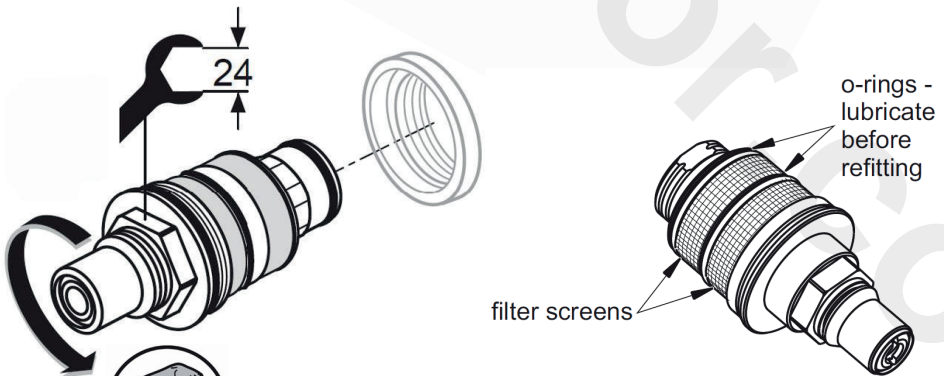

To clean the screens remove the o-rings shown. The screens will then slide off. When clean replace the screens then the o-rings which should be lightly greased with a WRAS approved silicone grease (eg Kluber Unisilikon GBU2)



12 Flow cartridge replacement

To replace the flow control cartridge, ISOLATE WATER SUPPLIES FIRST.
Drain down the pipe work as much as possible.



Max
12Nm

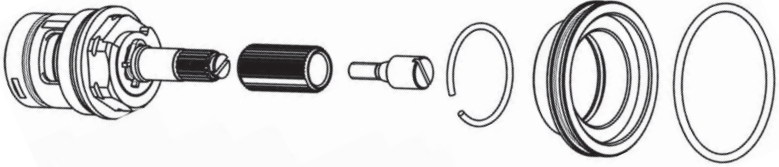

1. Undo the grub screw that secures the handle.
2. Pull off the flow control handle & this will expose the cartridge spindle.
3. Pull off the flow control shroud. A brass ring supports the shroud, pull this brass ring off too. It is retained on the flow control valve using a snap clip. This will expose the remainder of the flow control cartridge. The brass ring should have an o-ring fitted on the outside & a snap ring on the inside.
4. Unscrew cartridge with a 17mm A/F deep socket, expect some trapped water to escape. Replace the cartridge if necessary. When refitting cartridge, do not over tighten, hand tighten the first few threads, maximum torque 12Nm.
5. The black drive spindle (sleeve) should be refitted to the new cartridge.
ENSURE PARTS ARE REASSEMBLED IN THE CORRECT SEQUENCE.

13 Diverter cartridge replacement

To replace the diverter cartridge, ISOLATE WATER SUPPLIES FIRST.
To drain off some off the water inside the valve-box, turn diverter handle to tub fill.

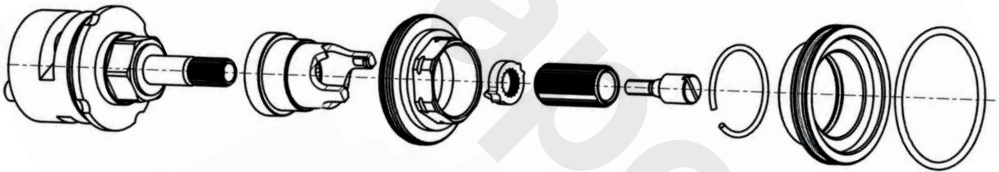

1. Undo the grub screw that secures the handle.
2. Pull off the diverter handle & this will expose the cartridge spindle, see 6.3.
3. Pull off the diverter shroud. A brass ring supports the shroud, pull this brass ring off too. It is retained on the diverter clamping bush using a snap clip. The brass ring should have an o-ring fitted on the outside & a snap ring on the inside. This will expose some of the diverter cartridge.
4. Unscrew the diverter clamping bush with a 22mm A/F deep socket. This will release the plastic positional moulding & the diverter cartridge. Expect some trapped water to escape. Replace the diverter if necessary.
5. The black drive spindle & positional sleeve should be refitted to the new cartridge (undo the screw fitted to the spindle).

ENSURE PARTS ARE REASSEMBLED IN THE CORRECT SEQUENCE.

See next page for set-by-step re-assembly information.

Refer to 6.3 for assembling handle.

NOTE: If the outlet pipes from the valve-box have been reversed during installation, this problem can be solved (in other words the tub fill connection has been made to the top of the valve-box). Remove the diverter cartridge as detailed above, then rotate it 180° & refit. The cartridge lug will fit into the secondary hole (D) shown on the next page.

13 Diverter cartridge replacement cont'

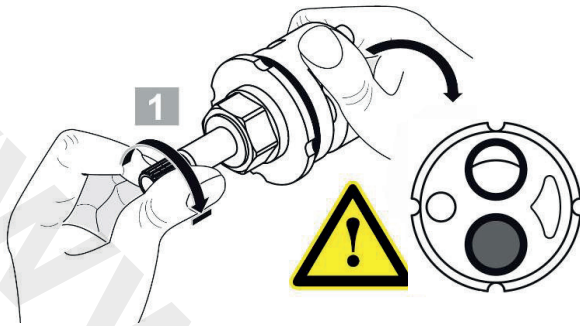

To refit the diverter cartridge:

1. Rotate the diverter spindle fully clockwise. Orientate the diverter as shown to view the bottom. With the locating lug on the left, check that the lower diverter port is closed.
2. Align the locating lug on the bottom of the diverter to the right hand hole in the valve casting (A). Slide the diverter into the bore & ensure the lug has been correctly located into hole A.

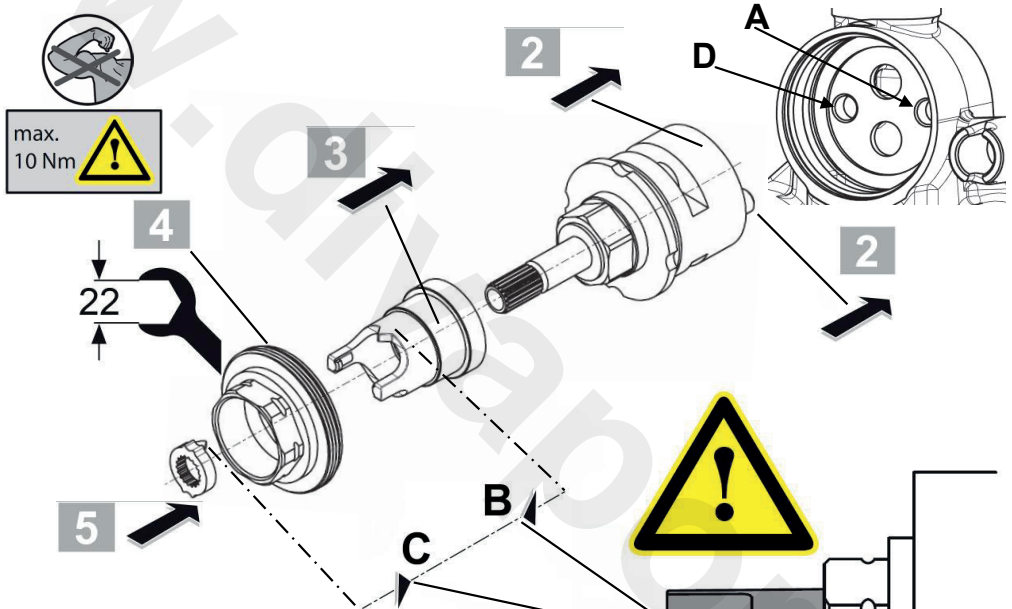

3. Slide the plastic positional moulding onto the diverter, engaging the hexagons on both parts. Ensure the moulding is orientated as shown above, observing that the pointer (B) is at the top.
4. Slide the clamping bush into place & rotate the bush clockwise thus engaging the first few threads. Use a 22mm A/F deep socket to tighten. When refitting cartridge, do not over tighten the clamping bush, maximum torque 12Nm.
5. Fit the positional sleeve onto the diverter spindle, ensure the pointer (C) is aligned to pointer (B). Both parts are splined, so the sleeve can be removed rotated & refitted until alignment is achieved. Once aligned, press the sleeve firmly. This will force the two lugs on the black moulding to move apart thus allowing the sleeve past. The sleeve should bottom-out on the brass spindle & the lugs on the black moulding snap back into position thus trapping the sleeve.
6. Confirm pointers are align as shown (plan view). Fit the black drive spindle & tighten the screw to secure. Reverse the sequence & reassemble the parts.
ENSURE PARTS ARE REASSEMBLED IN THE CORRECT SEQUENCE.

14 Check-valve cartridge replacement

To replace the check valve cartridges: (ISOLATE WATER SUPPLIES FIRST)

1. Remove all the chromed trim kit parts, see 6.1 & 6.2.
2. This should expose the check-valve housings, see 5.8.
3. Using a 15mm A/F socket undo the check-valve housings (x2), expect some trapped water to escape.

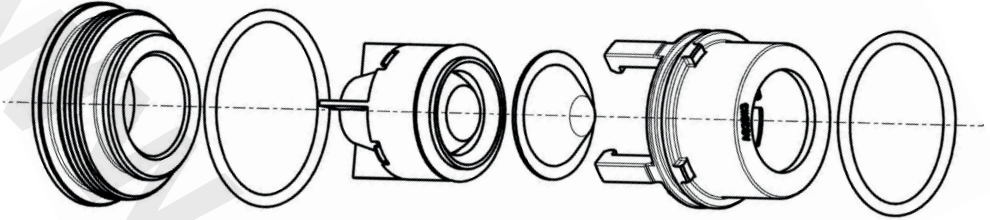

4. Unclip the moulding from the brass housing to release the check-valve & filter mesh.
5. Clean or replace the parts & reassemble.
6. Reverse the sequence & re-fit the check-valve housings back into the valve-box.
ENSURE PARTS ARE REASSEMBLED IN THE CORRECT SEQUENCE.

15 Cleaning chrome trim

When cleaning the shower valve always use soap based cleaners. Never use abrasive or scouring powders and never use cleaners containing alcohol, ammonia, nitric acid, phosphoric acid, organic solvents or disinfectants.

16 Spare parts

A 6453 AA A 6456 AA

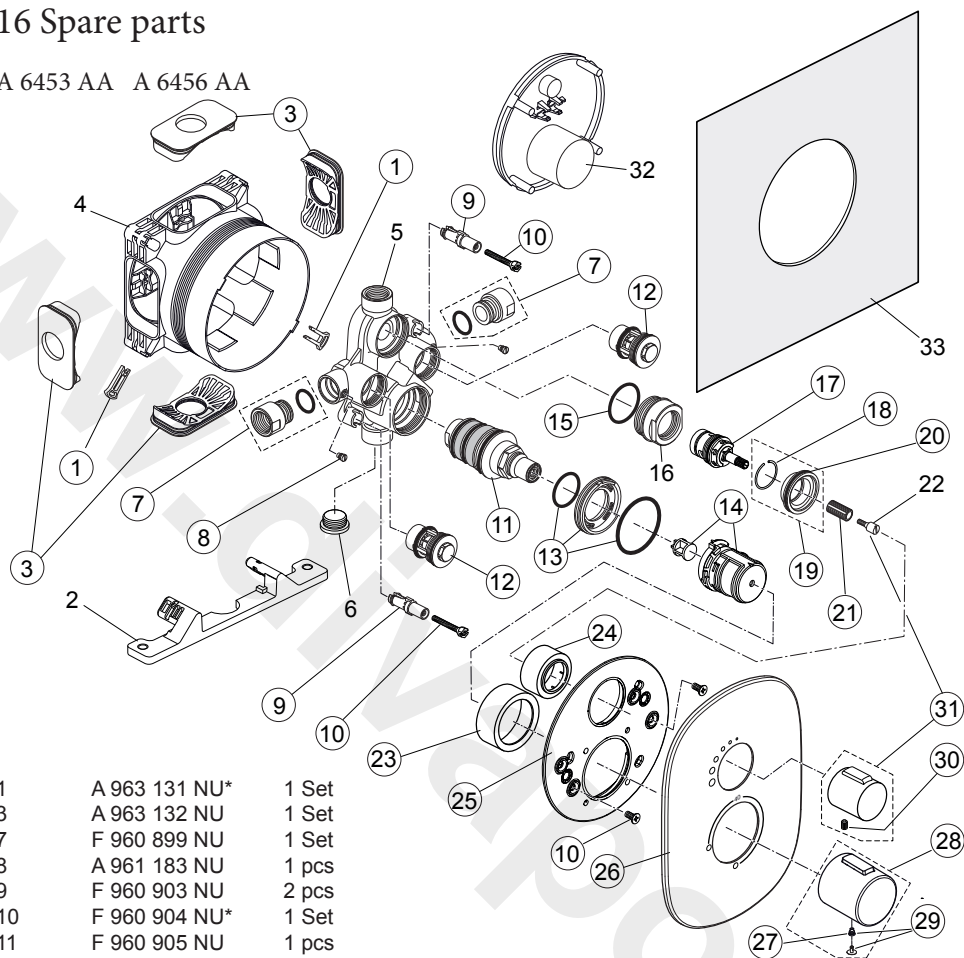

1	A 963 131 NU*	1 Set
3	A 963 132 NU	1 Set
7	F 960 899 NU	1 Set
8	A 961 183 NU	1 pcs
9	F 960 903 NU	2 pcs
10	F 960 904 NU*	1 Set
11	F 960 905 NU	1 pcs
12	F 960 906 NU	1 pcs
13	F 960 907 NU	1 Set
14	F 960 908 NU	1 Set
15	A 963 154 NU	1 pcs
17	A 960 898 NU	1 pcs
18	A 962 368 NU	1 pcs
19	F 960 909 NU	1 Set
20	A 960 183 NU	2 pcs
21	A 963 196 NU	2 pcs
23	F 960 910 AA	1 pcs
24	F 960 911 AA	1 pcs
25	F 960 912 NU	1 pcs
26	F 961 043 AA	1 pcs
27	A 961 095 NU	1 pcs
28	F 960 952 AA*	1 pcs
29	A 962 149 AA	1 Set
30	A 960 229 NU	1 pcs
31	A 860 957 AA	1 Set
33	A 6134 AA	1 Set

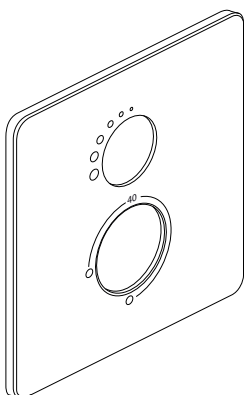

A 6456 AA
F 960 915 AA

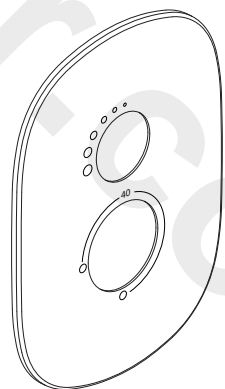

A 6453 AA
F 961 043 AA

* Universal-Set - not all parts are needed

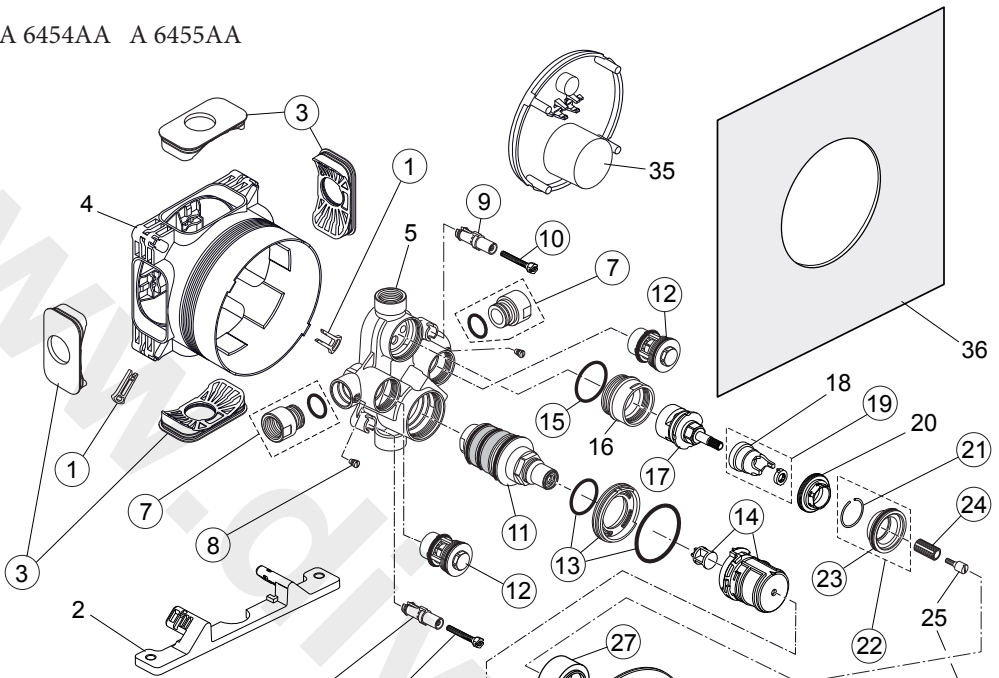

- | | | |
|----|---------------|-------|
| 1 | A 963 131 NU* | 1 Set |
| 3 | A 963 132 NU | 1 Set |
| 7 | F 960 889 NU | 1 Set |
| 8 | A 961 183 NU | 1 pcs |
| 9 | F 960 903 NU | 2 pcs |
| 10 | F 960 904 NU* | 1 Set |
| 11 | F 960 905 NU | 1 pcs |
| 12 | F 960 906 NU | 1 pcs |
| 13 | F 960 907 NU | 1 Set |
| 14 | F 960 908 NU | 1 Set |
| 15 | A 962 848 NU | 2 pcs |
| 17 | A 962 480 NU | 1 Set |
| 19 | A 962 481 NU | 1 Set |
| 21 | A 962 368 NU | 1 pcs |
| 22 | F 960 909 NU | 1 Set |
| 23 | A 960 183 NU | 2 pcs |
| 24 | A 963 196 NU | 2 pcs |
| 26 | F 960 910 AA | 1 pcs |
| 27 | F 960 911 AA | 1 pcs |
| 28 | F 961 108 NU | 1 pcs |
| 29 | see right | 1 pcs |
| 30 | A 961 095 NU | 1 pcs |
| 31 | F 960 952 AA* | 1 pcs |
| 32 | A 962 149 AA | 1 Set |
| 33 | A 960 229 NU | 1 pcs |
| 34 | A 860 957 AA | 1 Set |
| 36 | A 6134 AA | 1 Set |

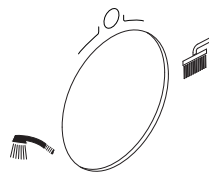

A 6454 AA
F 961 006 AA



A 6455 AA
A 860 958 AA

* Universal-Set - not all parts are needed

A 6457 AA A6458 AA

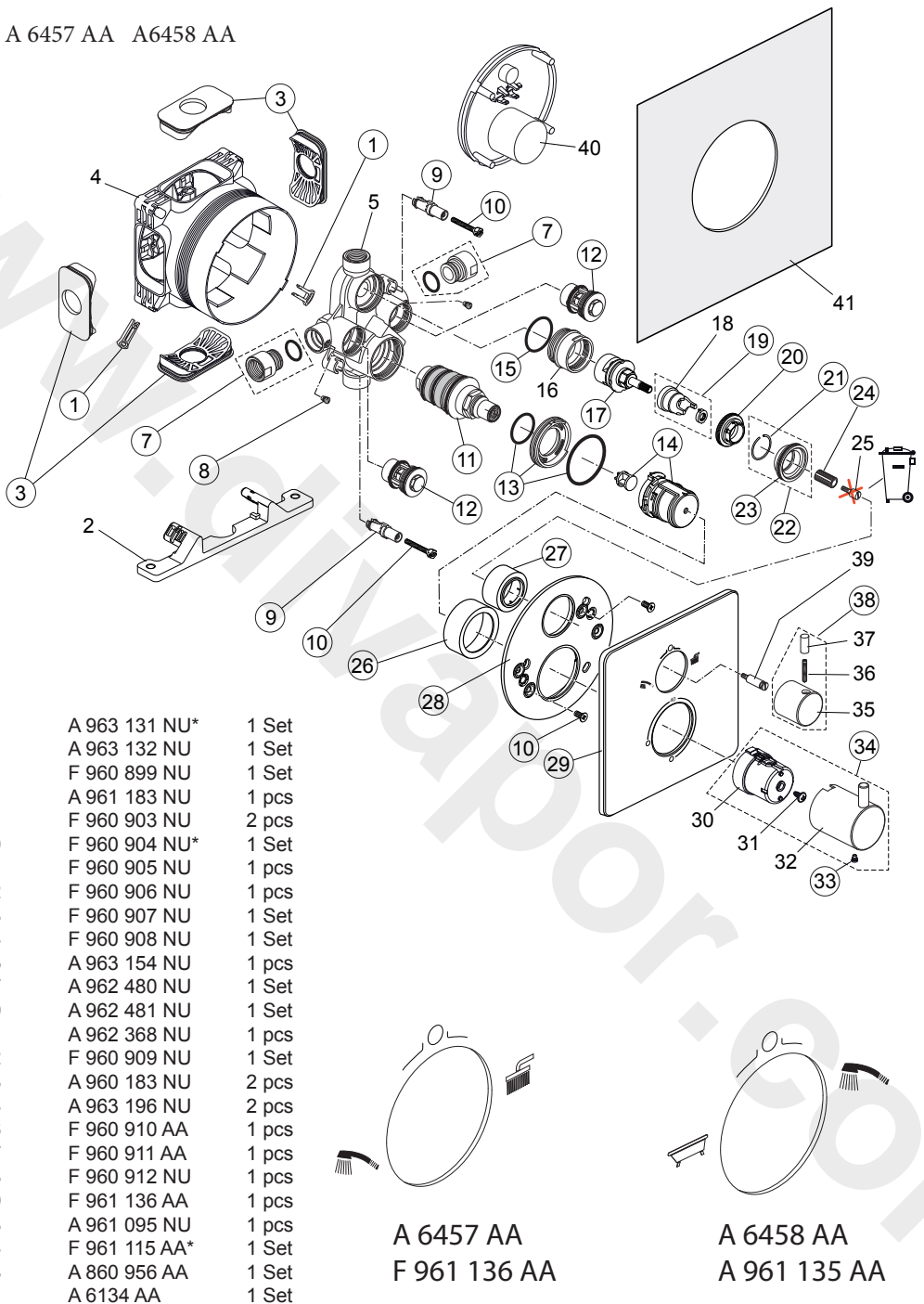

* Universal-Set - not all parts are needed



CUSTOMER CARE HELP LINE

0870 129 6085

CUSTOMER CARE FAX

01482 499611

E-MAIL

UKcustcare@idealstandard.com

Ideal Standard International NV
Corporate Village - Gent Building
Da Vincilaan 2
1935 Zaventem
Belgium

www.idealstandardinternational.com

Ideal Standard pursues a policy of continuing improvement in design and performance of its products. This right is therefore reserved to vary specification without notice.

Sottini is a division of
Ideal Standard (UK) Ltd

Ideal Standard,
The Bathroom Works, National Avenue
Kingston-upon-Hull, HU 4HS, England

1119 / A 868 000
Made in Germany