

# SOTTINI SHOWERS

---



Sottini Therm



Sottini Traditional



Globe Therm



Alchemy

## Installation Instructions

---

E5385 Sottini therm built-in thermostatic mixer

E5175 Globe therm built-in thermostatic mixer

E3116 Sottini traditional built-in thermostatic mixer

A5800 Alchemy built-in thermostatic mixer

Sottini

### INSTALLER:

*After installation please pass this instruction booklet to user*

Sottini thermostatic shower mixers are designed to be installed on normal UK low pressure storage tank fed systems, unvented high pressure systems, modulating instantaneous water heaters or modulating combination (combi) boilers. They are suitable for all pumped applications.

## WATER REGULATIONS

Hot and cold water supply pressures must be reasonably balanced and from a common source - both from storage or both from a supply pipe. (IRN 101). The mixers will function within specification on unequal pressures up to a ratio of 5 : 1, but it is not recommended that the cold supply be connected to the rising main and hot to the tank fed supply as the pressure differential is likely to exceed the 5:1 ratio.

The minimum pressure for correct operation is 0.1 bar (1m head - see Figure 5). Pressure head is measured as the vertical distance between the bottom of the cold water storage tank which feeds the hot water system and the highest point on the shower spray plate.

When installing with a shower pump the use of a secondary tapping from the cylinder is highly recommended.

Figure 1 shows the various methods of connecting the hot water pipe to the cylinder - the most preferred on the left and the least preferred on the right.

The fitting should be so installed as to be readily accessible for examination, repair, replacement or operation. (IRN 111).

The temperature of the hot water must not exceed 85°C but the installer's attention is drawn to code of practice BS 6700 which recommends that stored hot water should normally never exceed 65°C. For correct operation of the valve, a minimum of 52°C is required.

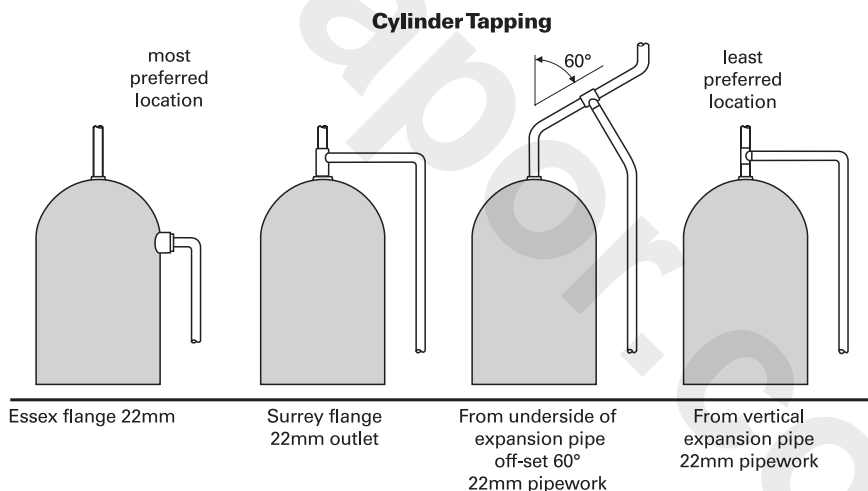

**Figure 1 Preferred locations of cylinder tapping**

When installing on a modulating combination boiler it is sometimes possible for the interaction of a thermostatic valve with the combi to cause the boiler to cut out and cut in again with the result that the water will become alternately cold and hot. To overcome this, flow restrictors should be fitted upstream of the thermostatic valve.

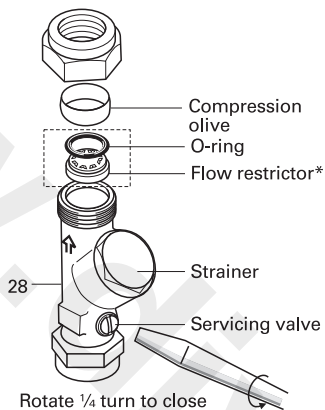

**Figure 2 in-line filter and service valve showing restrictor**

Sottini supply in-line strainers/servicing valves (28) which include these flow restrictors. These should be inserted in the downstream side of the servicing valve as shown on Figure 2. It is essential that they are positioned the right way round as shown in the sketch. Remove the compression nut and olive from the outlet side of the Isolating valve and place the restrictor in the outlet. Push to the bottom of the recess. Fit O-ring in the visible rebate around the edge of the restrictor and push home until it is fully in the rebate. Use the tip of a small screwdriver or similar to achieve this.

**CATEGORIES OF RISK**

The water regulations published in 1999\* take a new approach to backflow in that they look at

different categories of risk. The installer must assess the risk from the various categories of fluid in adjacent appliances before determining the level of backflow protection required for a particular installation. Figures 3 & 4 outline the protection required in various installations.

**CATEGORY 3 RISK**

Water in a shower tray, basin or bathtub is considered to be a fluid category 3 risk which is a fluid which represents a slight health hazard if it were to find it's way back into the supply pipe. For this reason it must not be possible for any flexible shower head to be able to enter any adjacent washbasin, bath or shower tray unless appropriate protection is employed. (See Figure 3).

If it is desired to allow the hand spray to be used inside say a bathtub or a basin it is essential that double check valves be fitted to the inlet on both hot and cold supplies to the thermostatic valve. Alternatively single check valves can be fitted at the inlets and an additional check valve should be fitted in the valve outlet.

No check valves need be fitted if the hand spray is prevented from reaching closer than 25mm of the spill over level of any such fixture.

**CATEGORY 5 RISK**

Water in a Sink, WC or Bidet is considered to be a fluid category 5 risk which is a fluid which represents a serious health hazard if it were to find it's way back into the supply pipe. For this reason it must not be possible for any flexible shower head to be able to enter any adjacent Sink, WC or Bidet. If the flexible hose to be fitted could reach into any such vessel, the requirements to the system design are so onerous it is better not to fit a flexible. Rather, a fixed overhead showerhead should be considered. (See Figure 4).

\*A guide to the Water Supply (Water fittings) Regulations 1999 and the Water Byelaws 2000, Scotland is published by WRAS (Water Regulations Advisory Scheme) Fern Close, Pen-y-Fan Industrial Estate, Oakdale, Newport, NP11 3EH. ISBN 0-9539708-0-9.

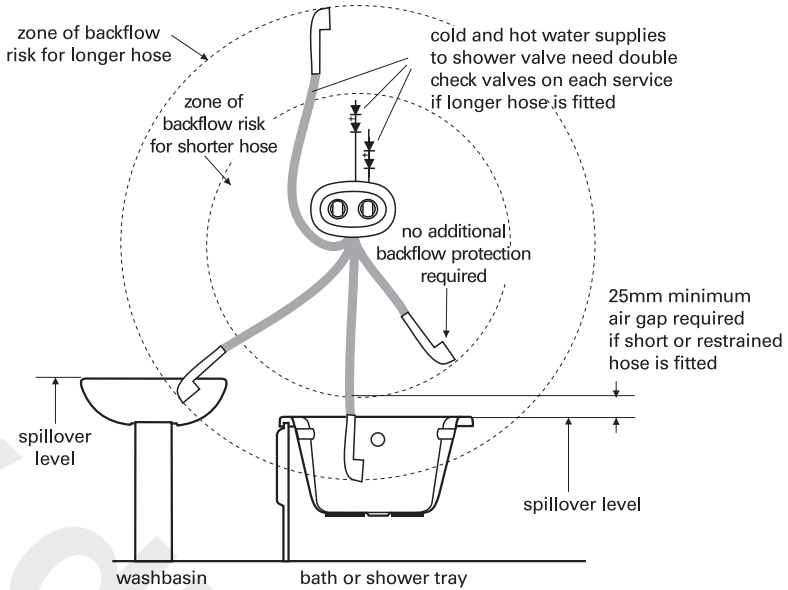

**Figure 3 Illustration of backflow risk from fluid Category 3 risk**

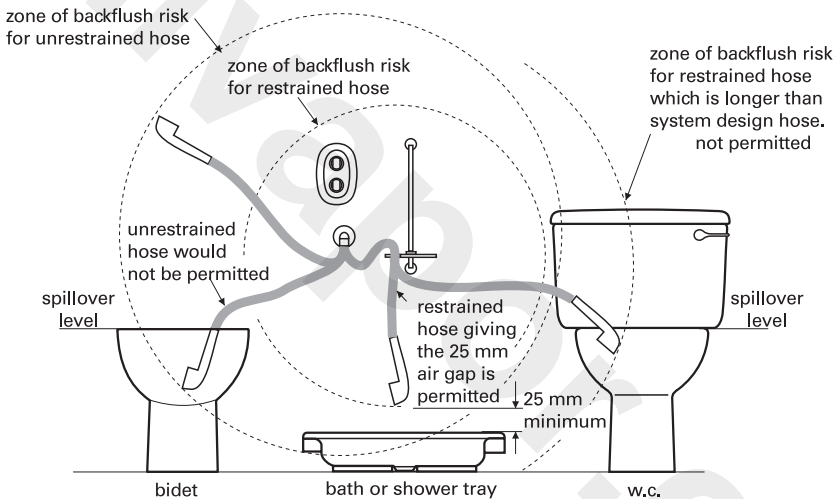

**Figure 4 Illustration of backflow risk from fluid Category 5 risk**

It will also be seen that this risk could change should the hose be taken out of the restraining device or should a longer replacement hose be fitted at a later date. Installers and householders are advised to take account of these factors

when fitting replacement hoses.

For pumped applications the pipe supplying the pump must not in addition supply an ascending spray bidet.

## GRAVITY/PUMPED SYSTEMS

Note: When hot supply is routed above the ceiling, (for example, in the loft space), the high level pipes should be installed with a fall, and must be vented at the highest point

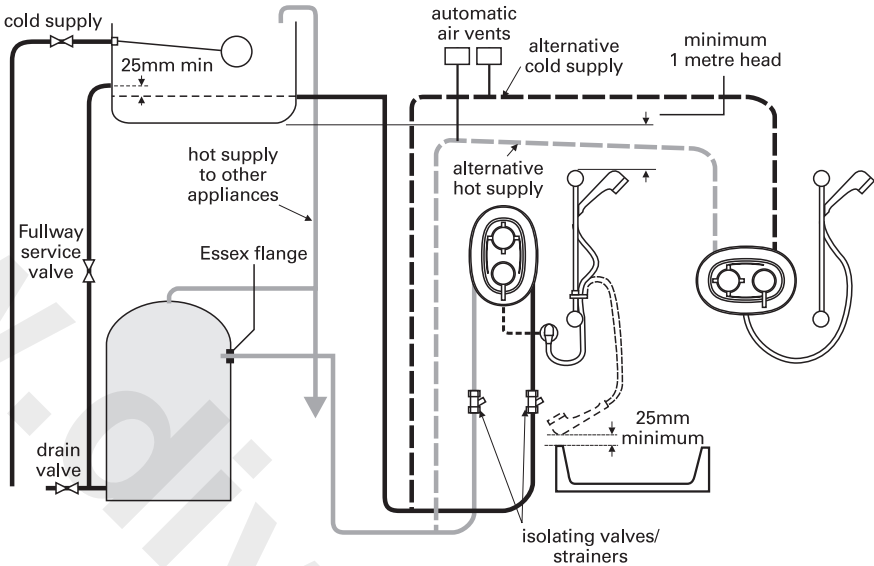

**Figure 5 Recommended system layout for gravity applications**

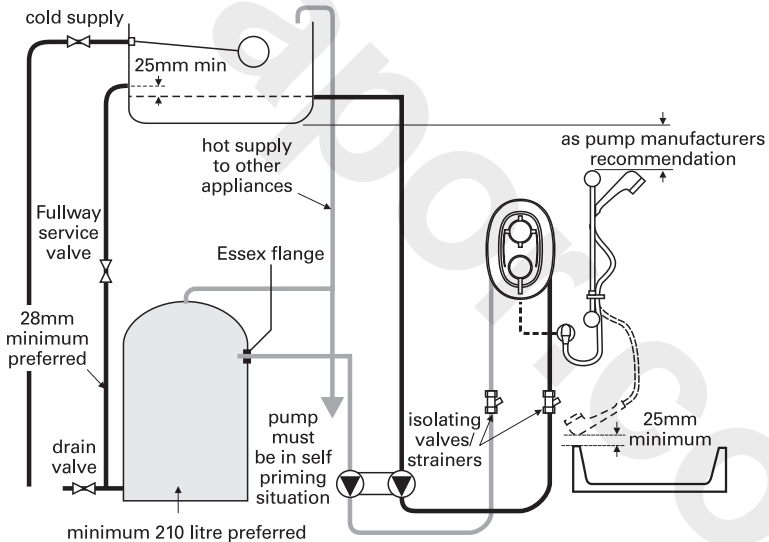

**Figure 6 Recommended pumped system layout**

## TECHNICAL DIMENSIONS

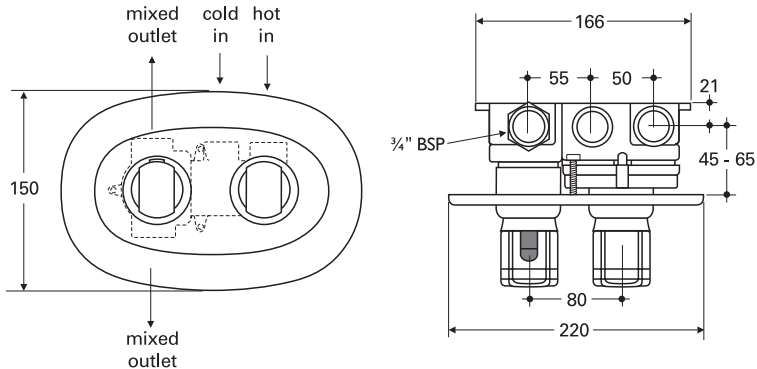

Figure 7 Sottini thermostatic shower valves installation dimensions

## INSTALLATION GUIDE

Connections on the built-in mixer body are  $\frac{3}{4}$ " BSP (female) and are marked "hot in", "cold in" and "mixed out" on the body casting. There are two mixed outlet ports, one of which must be plugged with the blanking plug supplied. For maximum flow performance the unplugged outlet should be connected to the wall elbow or the fixed overhead shower using 22mm copper. The  $\frac{3}{4}$ "/22mm connectors must be jointed to the valve body using jointing compounds or PTFE tape. Under no circumstances should soldered joints be used near the valve body as this will damage the fitting. It is recommended that isolation valves be fitted upstream of the valve body.

### SOTTINI THERM E5385 & GLOBE THERM E5175

The valve is supplied as per position 1 (Figure 8) with options for installation in positions 2, 3 & 4. Should positions 2, 3 or 4 be required then the temperature adjustment carrier will need to be repositioned so that the triangular raised mark at the rear is positioned at the top. The front handle carrier is rotated if necessary until the triangular indent is again at the top. The handle can then be pushed into position with the button to the top.

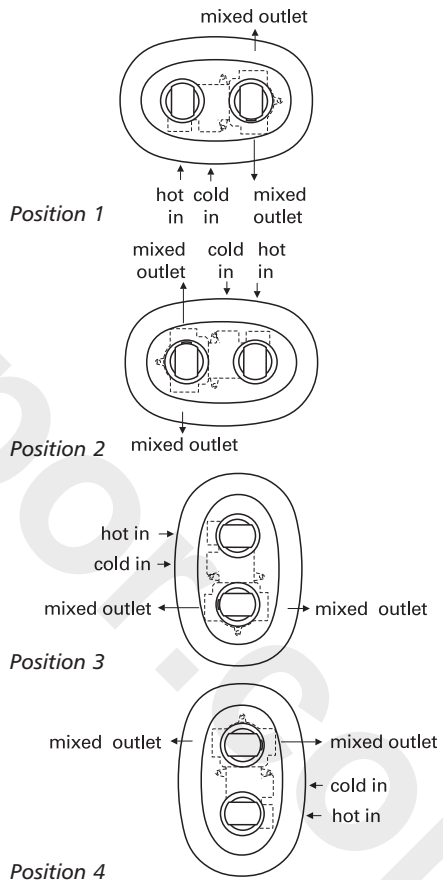

Figure 8

**SOTTINI TRADITIONAL BUILT-IN E3116 & SOTTINI ALCHEMY No. A5800**

These valves are supplied as per position 3 (Figure 8) and should only be installed in this orientation. Connections are the same as for Sottini Therm.

**Build-in guide**

1. All the fittings covered by this instruction are designed to be recessed into the wall. The depth of the recess should be measured from the finished wall surface to the rear of the valve body. There is an adjustment of 20mm in the installation depth. Recess depth is in the range 66mm minimum to 86mm maximum. These minimum and maximum depths are marked on the plaster guard (26).

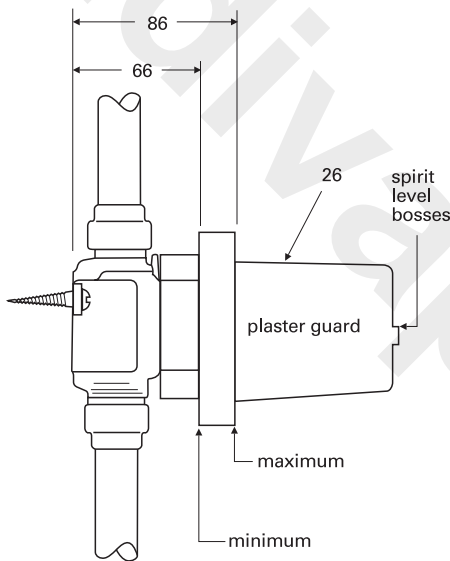

**Figure 9**

2. Chase out wall for mixer body and pipe work.
3. Remove plaster guard (26).
4. Fit blanking plug to appropriate port of the valve body and connect pipe work. (Do not solder near the valve body)
5. Replace plaster guard and check that the valve is horizontal (or vertical if positions 3 or 4 have been selected). The two bosses on the front of the plaster guard allow a spirit level to be placed on or against it. Check also that the valve is parallel to the wall surface.
6. Make good the wall by plastering around the valve up to the plaster guard.
7. Once the plaster has set the wall can be tiled and the plaster guard removed.
8. The temperature control handle can now be positioned so that the button is to the top (Sottini and Globe Therm). If the valve is not being fitted in the position as supplied then the temperature adjustment carrier will have to be repositioned as described on Page 8 under thermostatic cartridge replacement.
9. **The pipe work and valve body must now be flushed out.** Failure to do so will cause the thermostatic cartridge filters to become blocked resulting in reduced or erratic performance. The procedure for this is described on Page 7 under replacement of cartridges.
10. Fit the back cover plate and secure using the fixing screws (3). (These may need to be cut if valve is installed close to the minimum depth). Push front cover plate into position and fit operating handles.

## CARTRIDGE REPLACEMENT

## Flushing and replacement of cartridges &amp; gear clutch wheels

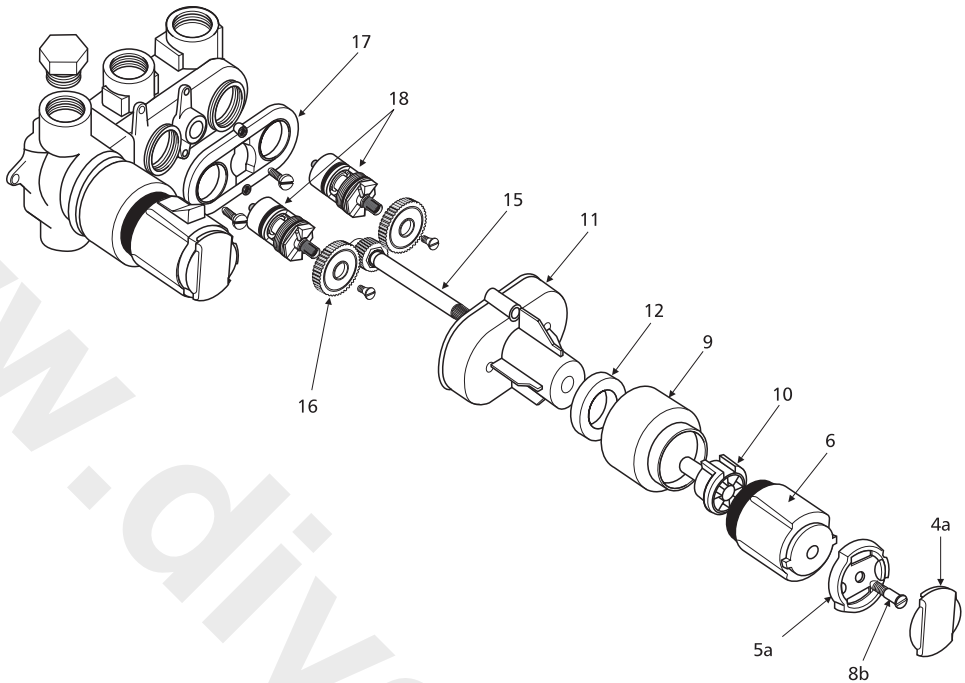
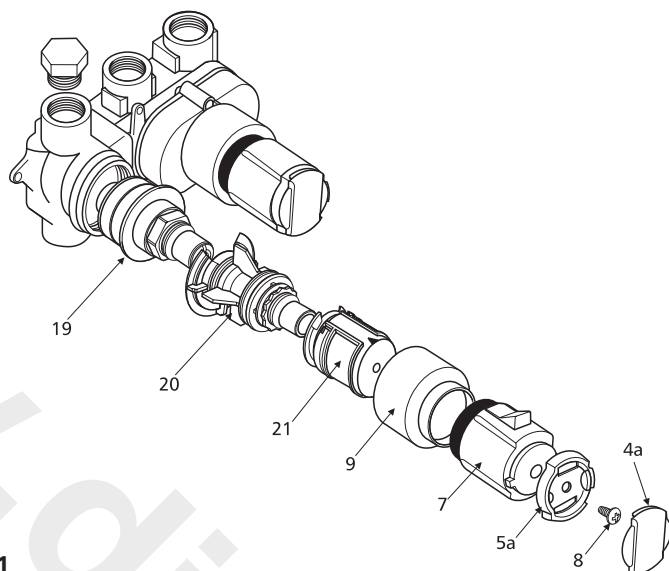

Figure 10

1. Remove handles. (see Pages 9/10 for details)
2. Remove the front cover plate (1) by prising forward using the small slots at the sides of the front cover plate.
3. Remove the two cover plate screws and pull off the back cover plate (2).
4. Remove the volume control handle carrier (10) by unscrewing screw (8b) and pulling off.
5. Pull off shroud (9)
6. Remove the two gear box cover fixing screws and pull off the gear box cover (11).
7. Pull out the drive shaft (15)
8. Loosen the two cartridge cone screws and remove the gear/clutch wheels (16) by pulling forward.
9. Lift off the rear gear box cover (17)
10. Isolate the shower valve from the supplies and unscrew the two cartridges (18) anticlockwise
11. Fit the flushing adapter (25) in place of the cartridges in turn and flush the pipework.
12. Assemble the valve in reverse order.
13. If fitting replacement cartridges and/or clutches they should be fitted at this stage.
14. Both cartridges must be in the closed position before fitting the gear clutch into position.

## THERMOSTAT REPLACEMENT THERMOSTATIC CARTRIDGE REPLACEMENT



**Figure 11**

1. If the volume control handle is in the off position it should not be necessary to isolate the valve from the supply for this operation.
2. Remove handles (7). (see pages 9/10 for details)
3. Remove the front cover plate (1) by prising forward using the small slots at the sides of the front cover plate.
4. Remove the two cover plate screws (3) and pull off the back cover plate (2).
5. Remove shroud by pulling forward (9)
6. Remove temperature handle carrier (4c) if one is fitted.
7. Remove the temperature adjustment carrier (21) by rotating the black locking latch and pulling forward.
8. Remove the rear temperature handle extension (20) by rotating the black locking latch and pulling forward.
9. The thermostatic cartridge (19) can now be removed by turning anticlockwise.
10. It is usually unnecessary fit a new thermostatic cartridge. Most problems occur because debris from the pipe work has blocked the cartridge filter screens.
11. The cylindrical filter screens can be removed for cleaning by removing the o-rings from the cartridge and sliding the screens off. Do not attempt to refit the cartridge with the filter screens missing. Any small particles of grit in the water supply will cause the mechanism to jam.
12. Grease the cartridge o-rings with silicone grease when they have been refitted.
13. If a replacement cartridge is being fitted, fit it at this stage.
14. The valve is assembled in reverse order.

The rear temperature handle extension (20) can be fitted on to the thermostatic cartridge (19) in any position.

The temperature adjustment carrier (21) will need to be refitted with the triangular raised mark on the rear of the carrier in the top position. Providing this assembly has not been separated, (i.e. the red clip removed) the unit will remain calibrated and no adjustments will be required. Ensure that the front handle carrier is rotated fully anticlockwise before refitting the temperature adjustment carrier to the rear temperature extension. The temperature handle is then refitted with the override button again in the top position.

## CALIBRATION

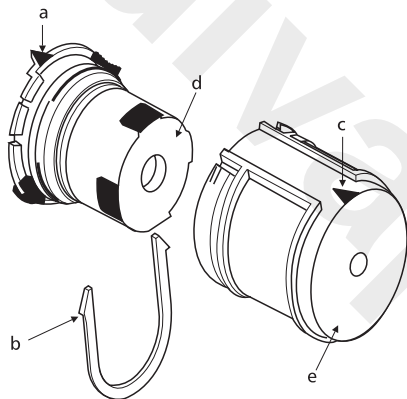

**Figure 12**

Sottini thermostats are factory calibrated and require no further calibration during installation. However, if the temperature adjustment carrier is accidentally disturbed and the calibration altered it is a simple procedure to recalibrate the unit. Before starting this you will need to ensure the hot supply temperature is above 52°C.

1. Remove the temperature control handle.
2. Remove the red U-clip (b) from the temperature adjustment carrier. Remove the front carrier (e).
3. Ensure the raised triangular mark (a) on the rear handle carrier is to the top.
4. Rotate the temperature adjusting spindle (d) until a temperature of 40°C is measured at the outlet.
5. Replace the front handle carrier ensuring the triangular indent (c) is to the top.
6. Refit the red U-clip.
7. Refit the temperature handle.

## HANDLE FITTING

### Sottini Traditional

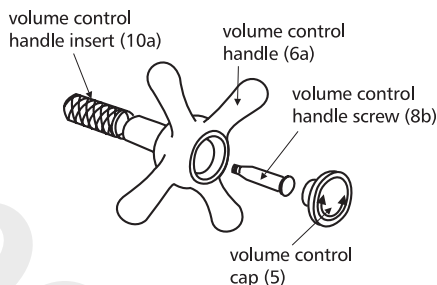

**Figure 13 Fitting Sottini Traditional volume control handle**

*The volume and temperature control handles are not pre-fitted but are supplied packed with the valves.*

The Traditional valve should be fitted only in position 3 as shown as in Figure 8

1. Push the volume control handle insert (10a) into the volume control handle (6a) and push this assembly on the drive shaft (15).

- Secure with the screw (8b) and finally push the cap (5) into place

**For correct operation the temperature handle must be fitted as follows**

- Remove the temperature adjustment carrier (21) by rotating the black latch and pulling the carrier forward.

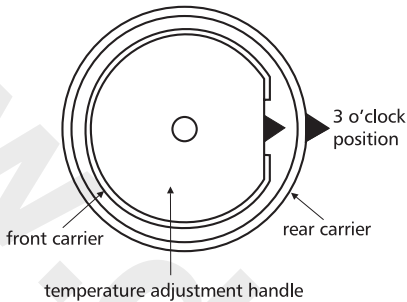

**Figure 14**

- Refit by pushing on until it clicks (the triangular mark on the front and rear carrier must be positioned at 3 o'clock)
- To fit the temperature handle (7a), push it onto the temperature adjustment carrier (21) with the lever at the 4 o'clock position. The wide key on the inside of the lever should engage with the key way on the temperature adjustment carrier (21).
- Secure the lever with the screw (8b)

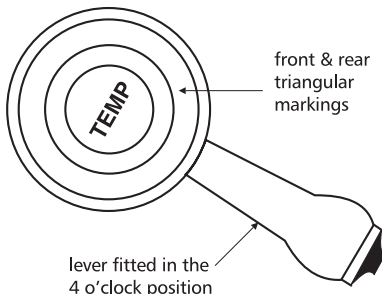

**Figure 15**

- When the lever is moved to the 6 o'clock position the water temperature should be approximately 35°C
- To increase the temperature, move the handle anticlockwise. See Figure 16

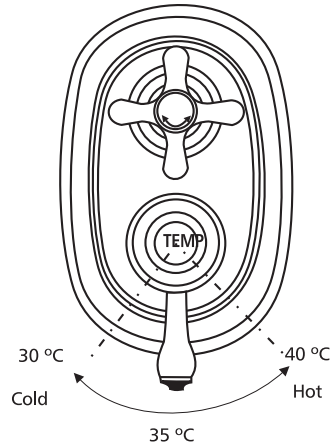

**Figure 16**

### Alchemy

**The Alchemy version of the shower valve operates in the same way as the Traditional and should be installed only in position 3 (see Figure 8)**

To fit the handles to Alchemy proceed as follows:

- Push the volume control handle carrier (10b) on to the splines of the gear wheel drive shaft (15) and secure with screw (8a).
- One of the four pins in the volume control handle (6b) is loose and will unscrew by hand. Remove this.
- Push the volume control handle (6b) onto the carrier (10b) ensuring that the missing pin position lines up with the un-slotted hole on the carrier (10b). (Figure 17)

4. Screw the pin into the handle ensuring that it engages in the hole in the carrier (10b)

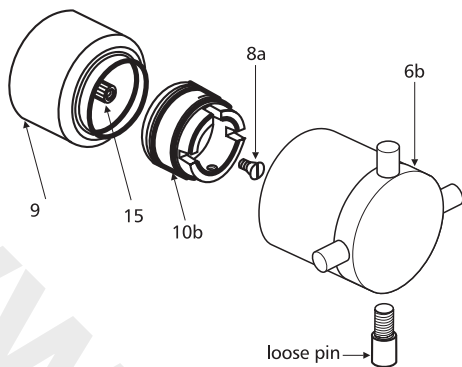
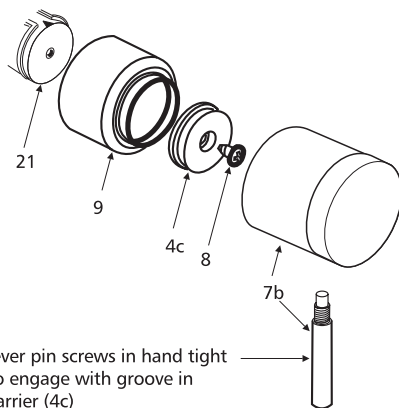

**Figure 17**

*For correct operation the temperature handle must be fitted as follows*

5. Remove the temperature adjustment carrier (21) by rotating the black latch and pulling the carrier forward.
6. Refit by pushing on until it clicks (the triangular mark on the front and rear carrier must be positioned at 3 o'clock)
7. To fit the temperature handle (7b), attach the Alchemy temperature handle carrier (4c) to the temperature adjustment carrier (21) using screw (8)

8. Unscrew lever pin from temperature handle (7b).
9. Push handle body on to the carrier (4c) with lever position at four o'clock
10. Screw the lever pin back into the handle body and tighten



**Figure 18**

11. When the lever is moved to the 6 o'clock position the water temperature should be approximately 35°C
12. To increase the temperature, move the handle anticlockwise. See Figure 16

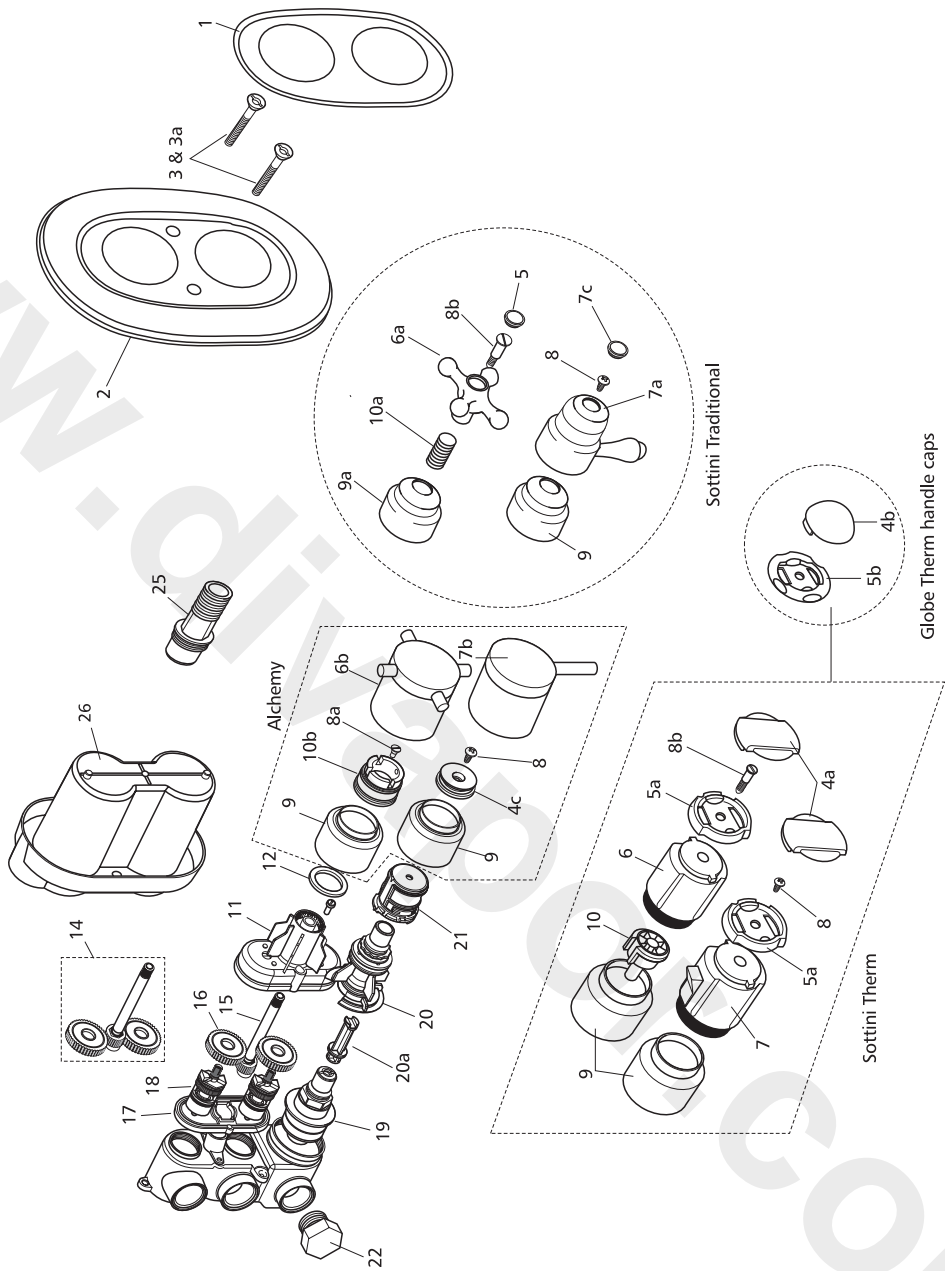

Figure 19

Ref.	Description		
1	Front cover plate	14	Gear/clutch wheels complete
2	Back cover plate	15	Gear/ wheel drive shaft
2a	Cover plate sealing rings	16	Gear/clutch wheels
3	Cover plate fixing screws 50 mm	17	Gear box back plate
3a	Cover plate fixing screws 60 mm	18	1/2" cartridge
4a	Sottini therm handle cap	19	Thermostatic control cartridge
4b	Globe therm handle cap	20	Temperature handle extension
4c	Alchemy temperature handle carrier	21	Temperature adjustment carrier complete
5	Traditional volume control handle cap	22	Blanking plug
5a	Sottini therm handle ring	25	Flushing adaptor outlet
5b	Globe therm handle ring	26	Mounting template/plaster guide
6	Universal volume handle base	27	Mounting template/plaster guide screws
6a	Traditional volume handle	28	In-line strainer/servicing valve complete with flow restrictor (not supplied)
6b	Alchemy volume handle		
7	Universal temperature handle base		
7a	Traditional temperature handle		
7b	Alchemy temperature handle		
8	Self tapping handle screw		
8a	Alchemy volume handle screw		
8b	Traditional volume handle screw		
9	Shroud		
9a	Traditional Volume control handle shroud		
10	Volume control handle carrier		
10a	Traditional volume control handle insert		
10b	Alchemy volume control handle carrier		
11	Gear box cover		
12	Gear box sealing washer		
13	Gear box cover fixing screws		

# Sottini

Sottini  
The Bathroom Works,  
National Avenue,  
Kingston upon Hull,  
HU5 4HS,  
England.

Telephone: (01482) 449513  
Telefax: (01482) 445886.

**CUSTOMER CARE HELPLINE**  
**01482 499380**  
**CUSTOMER CARE FAX LINE 01482 499611**

Sottini pursues a policy of continuing improvement in design and performance of its products. The right is, therefore, reserved to vary specification without notice.

Sottini is a division of  
American Standard Plumbing (UK) Ltd.

S231 03/02  
E965034