

Installation Instructions

OPOSTA BUILT-IN THERMOSTATIC MIXING VALVES WITH INTEGRAL DIVERTER

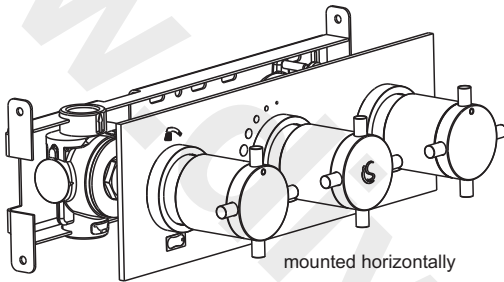

A5601AA Oposta 3-Control Built-in Thermostatic Bath Shower Mixer with 2-way diverter

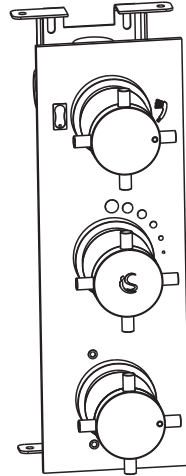

mounted vertically

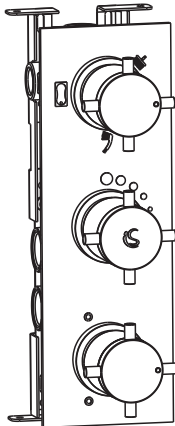

mounted vertically

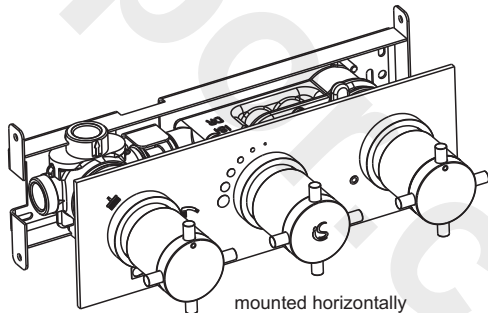

mounted horizontally

A5602AA Oposta 3-Control Built-in Thermostatic Bath Shower Mixer with 3-way diverter

INSTALLER:

*It is essential to flush the system as described in section 7
After installation please pass this instruction booklet to the user*

The fittings covered by these instructions should be installed in accordance with the Water Regulations published in 1999*.
Ideal Standard strongly recommends that these fittings are installed by a professional fitter.

*A guide to the Water Supply (Water Fittings) Regulations 1999 and the Water Byelaws 2000, Scotland is published by WRAS (Water Regulations Advisory Scheme) Fern Close, Pen-y-Fan Industrial Estate, Oakdale, Newport, NP11 3EH. ISBN 0-9539708-0-9

1 RANGE

This instruction sheet describes the installation of:

A5601AA Oposta 3-Control Built-in Bath Shower Mixer with Integral 2-way Diverter.

A5595AA Oposta 3-Control Built-in Shower/Shower Mixer with Integral 2-way Diverter.

A5602AA Oposta 3-Control Built-in Bath Shower Mixer with Integral 3-way Diverter.

The three controls allow the user to adjust temperature, flow and divert the mixed water to the selected outlet device.

The 2-way valve diverts between shower and bath or second shower and the 3-way diverts between overhead shower, shower handset and bath fill.

The valve body must be fitted before installing the trim kit.

2 PRE-INSTALLATION NOTES

The thermostatic valves described in this instruction are designed primarily for installation into a pre-fabricated "pod" style bathroom. These valves can easily be mounted from the rear of the pod wall during pod construction. This simplifies plumbing. The trim kit can then be fitted from the front (inside the pod) after tiling. These valves can also be installed into timber stud construction walls, method is discussed in section 5B.

The valves can be mounted either horizontally or vertically. For horizontal mounting keep the diverter end to the left, for vertical mounting keep the diverter end to the top. Otherwise the symbols on the escutcheon plate will be orientated incorrectly.

The mounting bracket is designed to bridge over two members of the pods steel framework spaced 260mm apart (vertical or horizontal). It is important to cut the correct size of slot into the plaster board to allow future maintenance of the valve cartridges.

3 DIMENSIONS

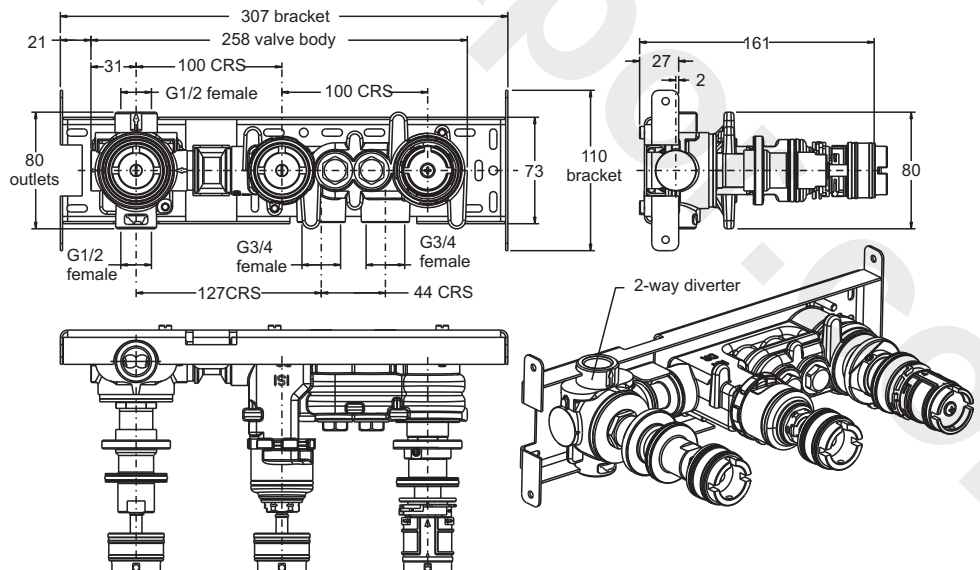

Figure 1 Oposta Thermostatic Mixer Valve body with 2-way diverter complete with mounting bracket for A5601AA and A5595AA

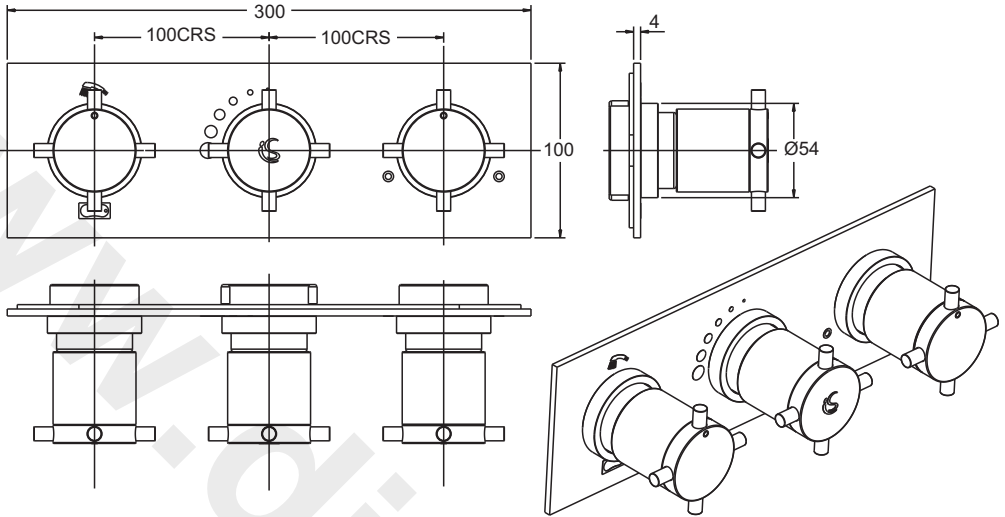

Figure 2 Trim Kit for Oposta Thermostatic Mixer with 2-Way Diverter

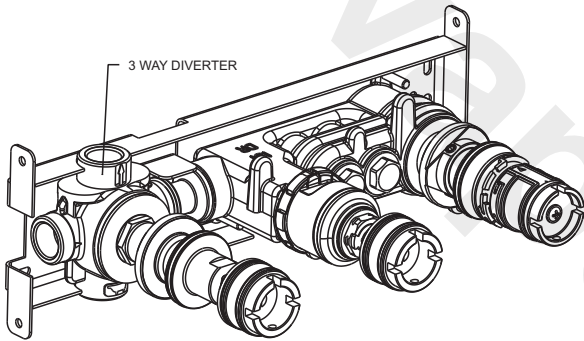

Figure 3 Oposta Thermostatic Mixer Valve body with 3-Way Diverter complete with mounting bracket for A5602AA

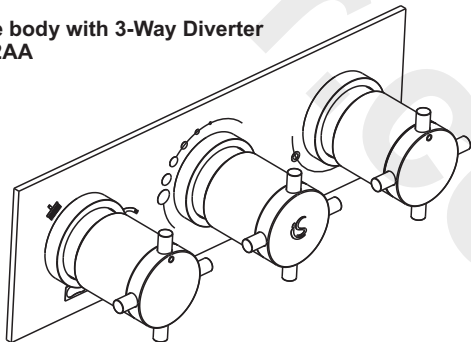

Figure 4 Trim Kit for Oposta Thermostatic Mixer with 3-Way Diverter

4 INSTALLATION OVERVIEW

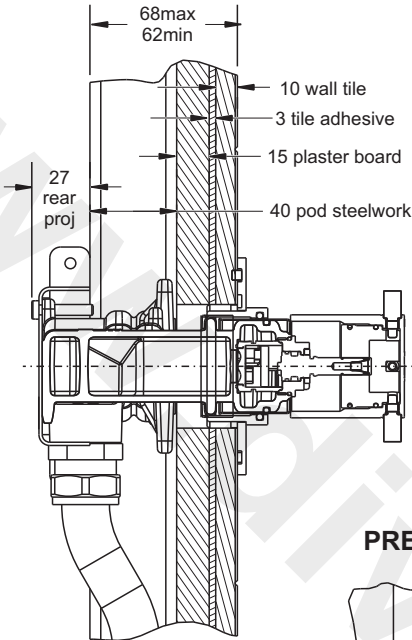

Figure 5 Section through typical pod wall

Two $\text{Ø}57$ holes can be cut into the plaster board at 200 horizontal (or vertical) centres, and then slotted-out as shown. A correctly sized slot in the pod wall plaster board will permit access to the valve cartridges for future maintenance.

For product A5602AA which has a 3-way diverter, it will be necessary to make a cut-out in the steel framework for connecting pipe work. This is not required for A5601AA or A5595AA with 2-way diverter.

These products are intended to be installed primarily onto a pod wall. Typical pod wall construction is shown here. When using this "bridging" installation method, the pod wall thickness should be in the range 62 to 68mm.

Once mounted onto the steel frame work, the valve will project 27mm out from the back of the pod wall.

The mounting bracket is designed to bridge over two members of the pod's steel framework. The distance between these members should be 260mm.

PREPARATION

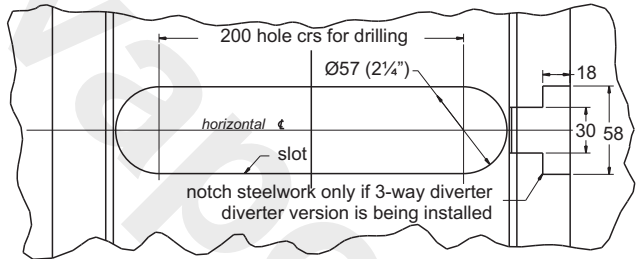

Figure 6 Recommended dimensions for slot in pod wall (plasterboard)

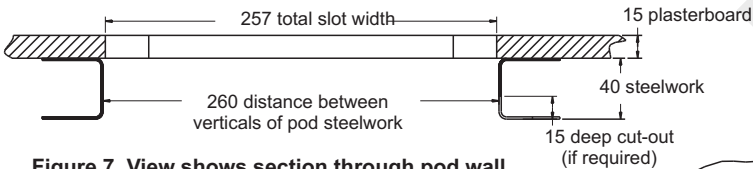
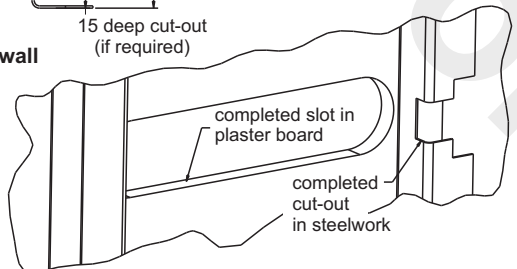

Figure 7 View shows section through pod wall

Figure 8 Rear view of prepared pod wall



5a MOUNTING VALVE INTO POD WALL

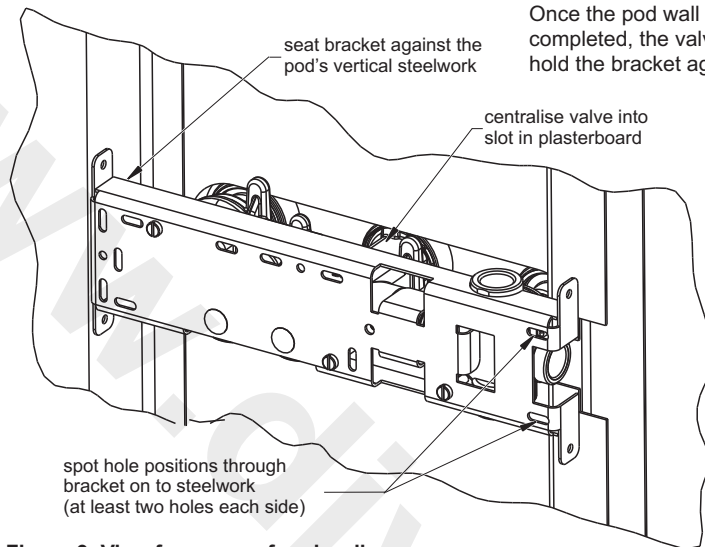

Figure 9 View from rear of pod wall

Once the pod wall preparation has been completed, the valve can be mounted. Firmly hold the bracket against the back of the pod framework and spot through suitable hole positions. The valve should be kept central in the plasterboard slot & horizontal. The slots in the mounting bracket are elongated and will allow some adjustment. The mounting bracket should be securely fixed to the pod framework, using at least 4 suitable bolts or screws.

A spirit level can be used on the top surface of the bracket to achieve an accurate horizontal level.

NOTE: The valve can be mounted either horizontally or vertically.

5b MOUNTING VALVE INTO TIMBER STUD WALL

PRE-INSTALLATION NOTES

These mixing valves can be installed into a timber stud construction wall. Two methods of installation are detailed in this section. The first method shows how the mounting bracket can be secured to the timber studs (verticals) and the second method shows the bracket being fixed to a timber noggin (horizontal).

The mounting bracket is very versatile permitting the multiple fixation options. The bracket can be secured from in-front of the wall or from behind.

Installation will be easier if the valve can be fitted before the plaster board is fastened to the timber framework. Pipe runs to and from the valve will also be easier to plumb. However, for retrofit fit applications, an area of plaster board approximately 400x400 should be cut away and then replaced after installation. This is necessary to facilitate pipe connections.

These mixing valves can be mounted vertically or horizontally, *see note in sect.2.*

As with most appliances installed into a stud wall, the framework will need to be adjusted to provide a means of fastening and supporting the appliance.

TIMBER STUD WALL CONSTRUCTION

Framework is normally constructed using 75x50 (3"x2") rough sawn timbers, for larger walls 100x50 (4"x2") can be used. Stud centres spacing of 400 is used here in discussion. Note that 450 and 600 centres are also commonly used -this usually depends on the plaster board size being used. Plaster board thickness of 12.5 (1/2") is generally recommended.

METHOD A: FIXATION TO STUDS

This method is suitable for frameworks constructed with either 75x50 studs or 100x50 studs.

Consider and decide on the desired mounting position of the valve. If this position does not fall between two studs, the framework will need to be adjusted. The bracket requires a gap between the studs of 307.

Assuming the mounting position falls between two studs at 400 centres, then a timber packing block should be fastened to one stud, as shown in fig 10. The packing block should be trimmed to provide a mounting gap of 307.

If installing product with 3-way diverter, one stud should be drilled out (as shown) to allow pipe connection.

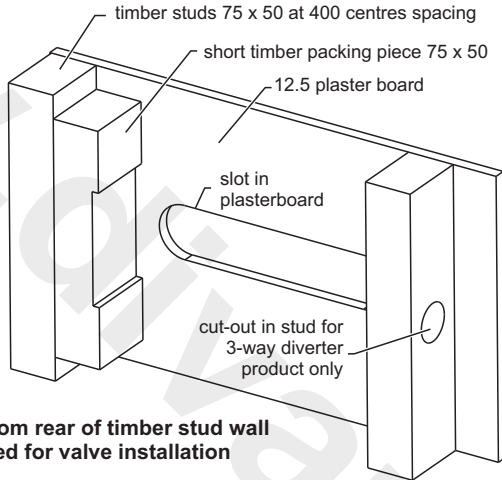

Figure 10 View from rear of timber stud wall prepared for valve installation

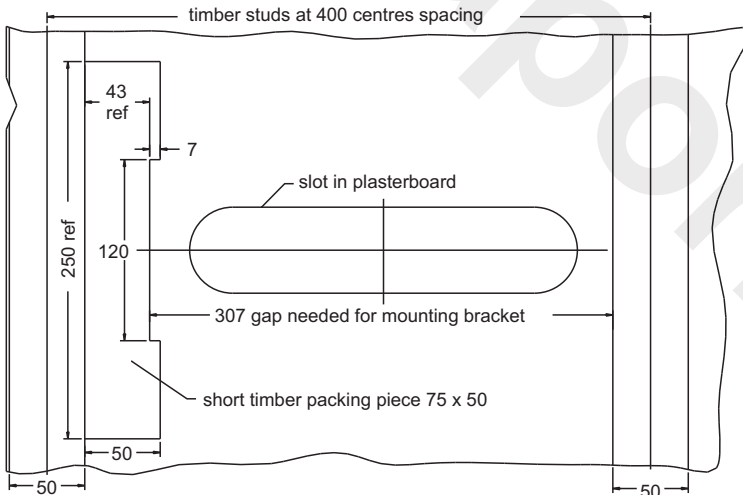

Figure 11 View from rear of timber stud wall showing dimensions

If plaster board is fastened to the front of the wall, then it can be slotted out as detailed in fig.6 in sect.4.

Ensure slot is correctly aligned either horizontally (as shown) or vertically.

Alternatively, the plaster board can be slotted when it is being fastened to the framework (after the valve has been mounted)

The valve can now be fastened to the framework using 4 suitable wood screws.

Use a spirit level along the top edge of the valve to ensure it is correctly aligned.

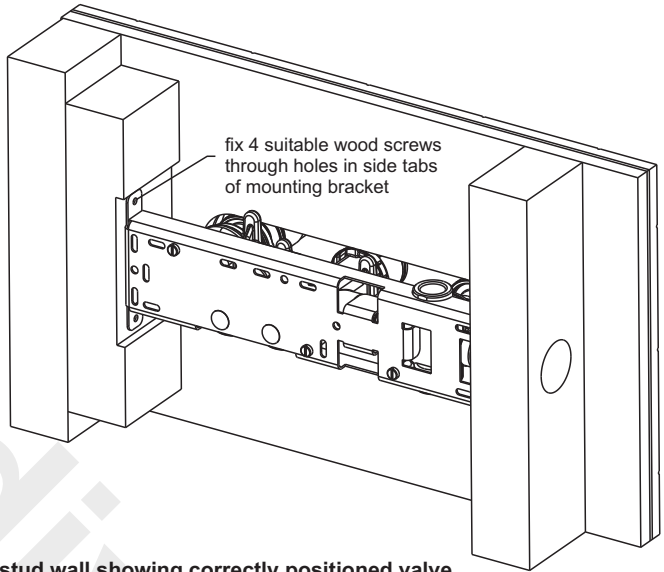
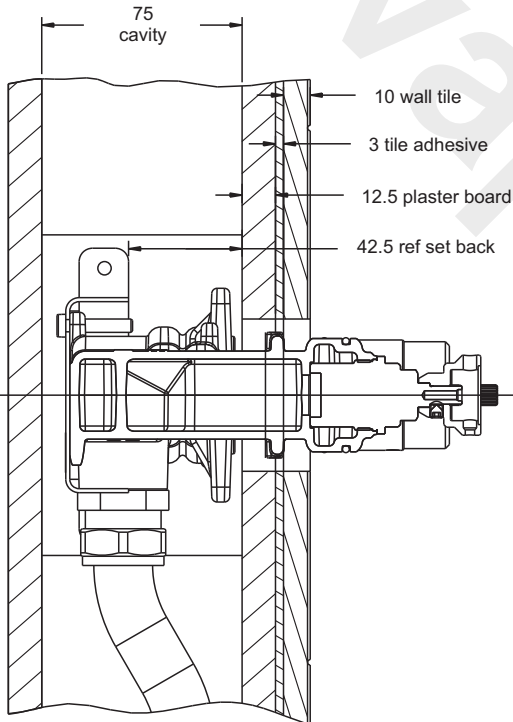

Figure 12 View from rear of stud wall showing correctly positioned valve



The exact mounting depth is dependent on the thickness of plaster board and tiles being used. The 42.5 dimension is given here as a guideline only.

Continue with the installation using sect.6 -plumbing.

Figure 13 Section through timber stud wall

METHOD B: FIXATION TO NOGGIN

This method is more suited to a timber stud wall constructed using 100x50 studs.

Consider and decide on the desired mounting position of the valve.

Assuming the mounting position falls between two studs at 400 centres, then a noggin should be fastened across the back of two studs, as shown in fig 14.

If installing product with 3-way diverter, one stud should be drilled out (as shown) to allow pipe connection.

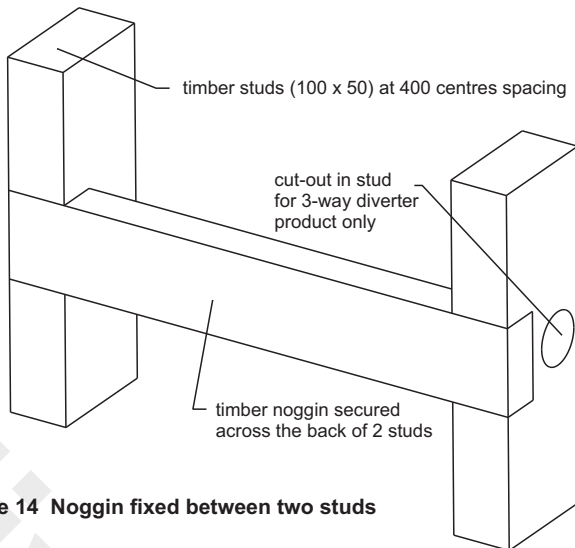

Figure 14 Noggin fixed between two studs

The valve can now be fastened to the noggin using 4 suitable wood screws.

Use the slotted holes in the back face of the bracket; these are elongated to provide adjustment for aligning.

Use a spirit level along the top edge of the valve to ensure it is correctly aligned.

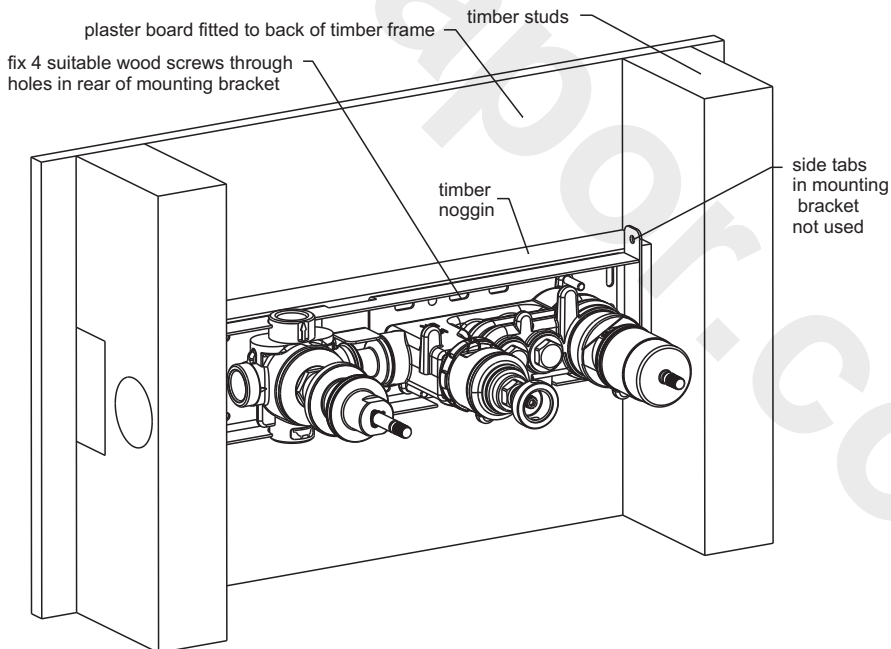

Figure 15 View from front of timber stud wall showing correctly positioned valve (3-way diverter version of valve shown)

The front plaster board can be slotted when it is being fastened to the framework (*after the valve has been mounted*). See details in fig.6 in sect.4.

The exact mounting depth is dependent on the thickness of plaster board and tiles being used. The 42.5 dimension is given here as a guideline only.

Continue with the installation using sect.6 - plumbing.

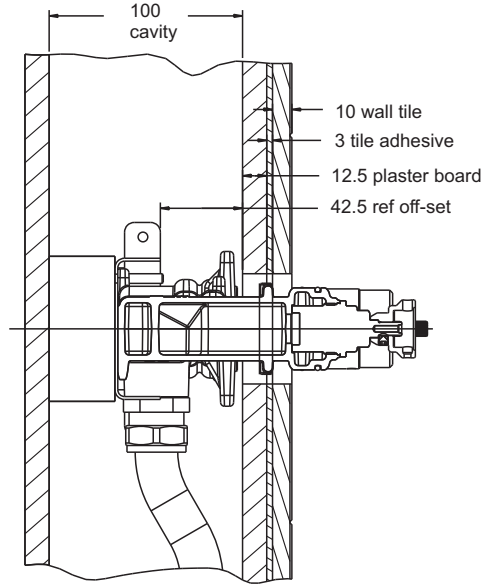

Fig 16 Section through timber stud wall

6 PLUMBING

Screw suitable connectors into the valve as shown above. Use a WRAS approved thread sealant, for example: Loctite 577 or Permabond A1044. Connectors as shown above are typically used for connecting 15mm and 22mm copper pipes.

For maximum flow performance, run Ø22mm supply pipes to the valve.

DO NOT use solder joints near the valve as this will cause damage.

Easily accessible isolation valves should be fitted to the supply pipes to facilitate future maintenance.

Alternatively, if the installer desires, push-fit connectors can be used with plastic pipes.

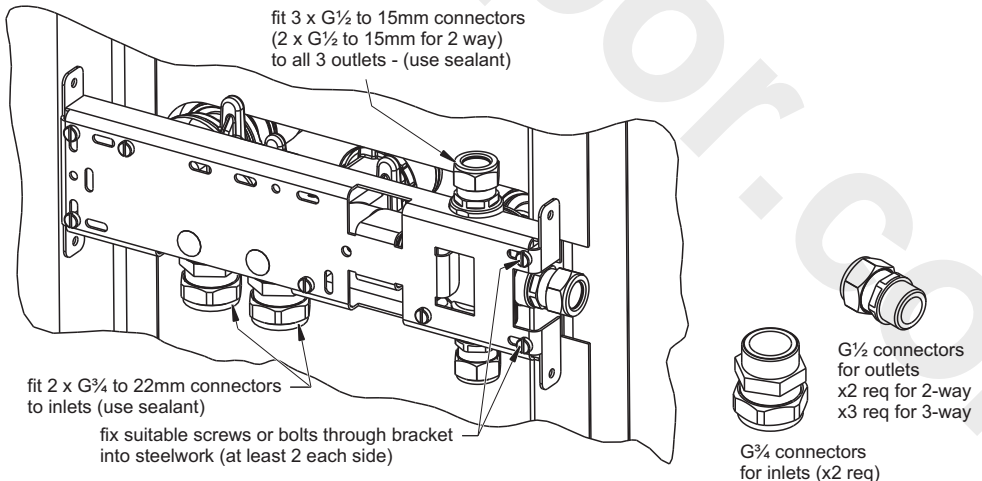

Figure 17 View from rear of pod wall with connectors fitted

available from all good plumbers merchants (not supplied)

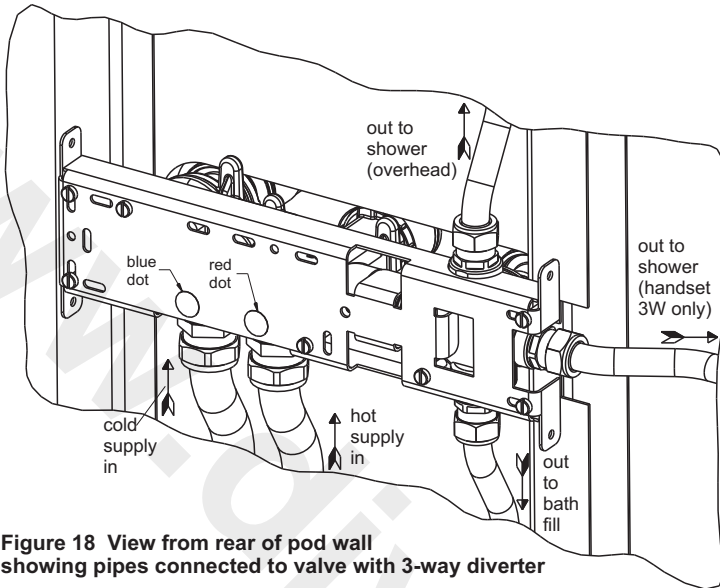

Figure 18 View from rear of pod wall showing pipes connected to valve with 3-way diverter

Pipe work connections should be made as shown. Red and blue dots on the bracket indicate hot and cold supply connections respectively. The outlets can be plumbed as shown. There will be either 2 or 3 outlets depending on the product being installed (2 or 3 way diverter). This completes the installation from the rear of the pod wall.

Test all connections for leaks at this stage

7 FLUSHING

The pipe work and valve body must now be flushed out otherwise the thermostatic cartridge filters could become blocked resulting in reduced or erratic performance.

To do this, remove the check valve housing from the hot side using a 17mm *a/n* socket. Place a suitable empty vessel under the product to collect discharging water. Gently turn on the hot supply until all debris has been purged from the system then replace the check valve. Repeat the procedure for the cold side check valve. After flushing, if in-line strainers have been fitted, check and clean the strainer elements.

8 CHECK VALVES

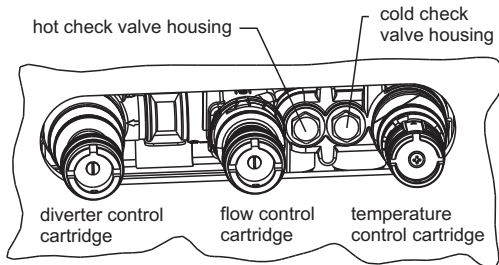

Figure 19 Completed built-in valve installation - viewed from inside pod - ready for fitting trim kit (after tiling wall)

This mixer is fitted with integral check valves which are essential to compliance with water regulations. To protect these from water borne debris it is strongly advised that the inlet supply pipes be fitted with in-line strainers. Should it become necessary to clean debris out of the check valve, care must be taken to ensure the delicate mechanism is not damaged during the process. The check valve housings are not interchangeable and must be re-installed in the same position from which they were removed.

It is important to connect the hot and cold supplies the right way round otherwise the valve will not function correctly. However, if the connections have been made the wrong way round the situation may be remedied by transposing the check valve housings.

9 INSTALLATION OF TRIM KIT

Once the valve installation has been completed and flushed, the trim kit can be installed from the front (inside the pod). The pod walls should be in a finished state (lined with ceramic tiles or similar) before fitting the trim kit. The same method is applicable to valves installed into timber stud walls.

The wall tiles should be carefully trimmed to match the slot cut into the plaster board of the pod wall. A correctly sized slot cut into the pod wall plaster board will permit access to the valve cartridges for future maintenance.

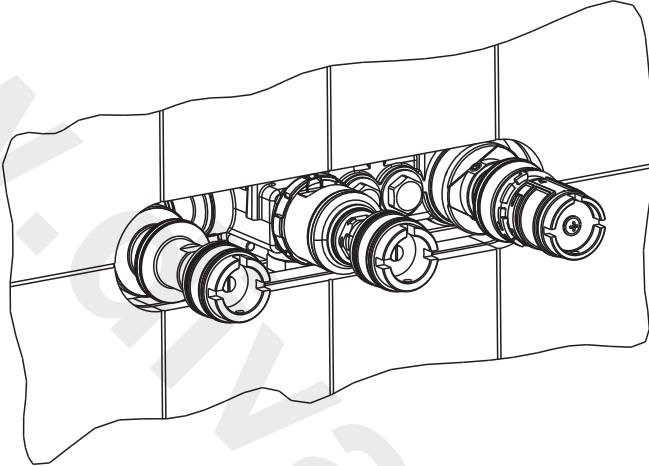
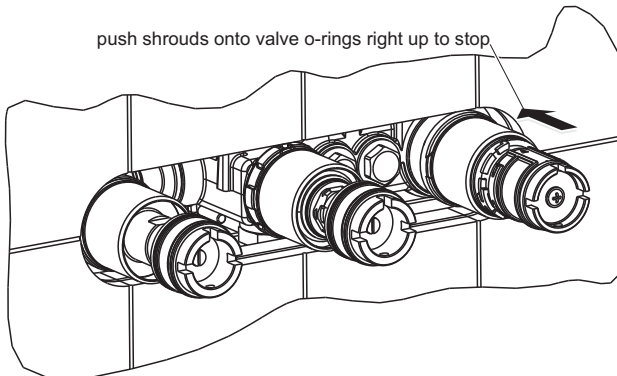

Figure 20 View of valve from inside of pod with wall tiled

10 FITTING THE SHROUDS

To install the trim kit, start by sliding the 3 shrouds onto the 3 projecting diameters of the valve body. The o-rings fitted onto the valve will offer some resistance, so push shrouds firmly until they stop. The shrouds are flared at one end to provide a leading chamfer to assist assembly onto the o-rings. Orientate the flared ends of the shrouds towards the valve body. If necessary the o-rings may be lubricated with water containing a little washing up liquid.



Note: Once the handles have been fitted, the shrouds can be slid forwards to meet the handles and close any visible gaps.

Figure 21 View of valve from inside of pod with shrouds fitted

11

ESCUTCHEON PLATE

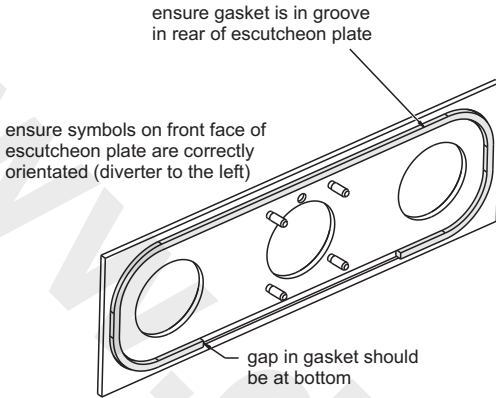

Figure 22 Escutcheon Plate (horizontal mounting)

ensure symbols on front face of escutcheon plate are correctly orientated (diverter at top)

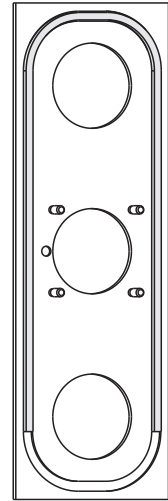

Figure 23 Escutcheon Plate (vertical mounting)

Remove the backing tape from the self-adhesive foam gasket. Carefully fit this gasket into the groove at the rear of the escutcheon plate. The gasket is intentionally shorter than the groove perimeter to allow any trapped water to escape. Therefore, the gap in the gasket should always be kept at the bottom edge of the plate.

Where valve is being mounted vertically, the gap will be along the bottom short edge (remember to keep diverter symbols at top).

Slide the escutcheon plate over the 3 shrouds, back to the tiled wall. Taking care not to damage the chromed surfaces, and ensure the plate is orientated correctly.

Hold plate in position, and slide the 3 grip rings over the shrouds. Screw the grip rings onto the valve as detailed in the next section.

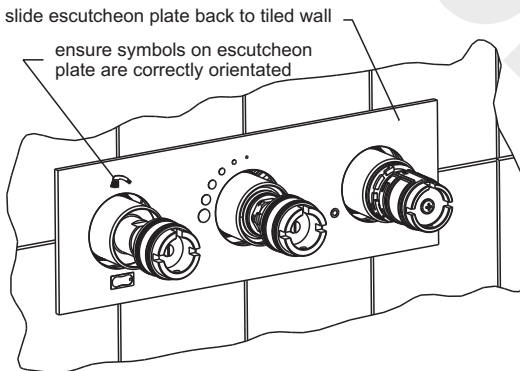

Figure 24 View of valve from inside of pod with escutcheon fitted

12 GRIP RING

Each grip ring should be fitted with an internal o-ring.

The o-ring inside the grip ring will rub on the shroud during assembly (if necessary the o-rings may be lubricated with water containing a little washing up liquid). Once in position, they will prevent water ingress.

The smaller diameter of the grip ring will pass through the escutcheon plate and the larger diameter will shoulder against it.

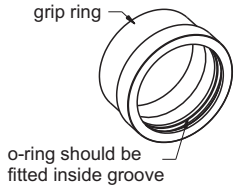

Figure 25 Grip ring

Each grip ring should be firmly hand tightened down to the escutcheon plate. The grip rings will push the escutcheon plate against the wall and compress the foam gasket in the process, making a water tight seal.

All three grip rings should be kept level to apply even pressure onto the gasket.

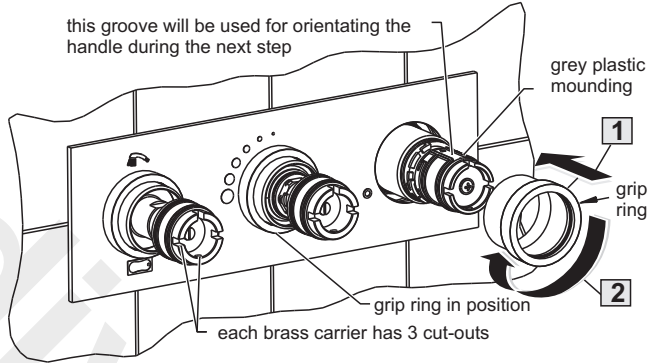

Figure 26 View of valve from inside of pod - grip rings being fitted

13 FITTING THE HANDLES

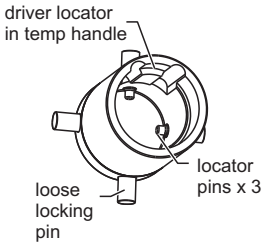

Figure 27 Temperature handle detail

NOTE: All 3 handles differ slightly, and these should be identified before commencing installation. **Temperature Handle** is shown here on the left. It is identified by looking inside the handle for the drive-locator as shown.

Flow Handle is identified by the IS logo on the face.

Diverter Handle is the same as flow diverter, but without the IS logo.

Next step is to fit the **temperature control handle**. First, remove the loose locking pin from the bottom of the handle.

Position the temperature handle such that the drive-locator slides along the groove in grey plastic moulding attached to the right hand side control on the valve.

The 3 locator pins visible inside the handle (fig.27) MUST fit into the 3 grooves cut into the brass adaptors (fig.26)

When the handle is correctly seated, the loose locking pin can be screwed back into the handle. This pin should enter the hole in the brass adaptor and secure the handle to the valve.

If necessary, the brass adaptor can be rotated to achieve alignment. This is done by backing-off the centre screw in the adaptor, rotating the adaptor & then retightening the screw.

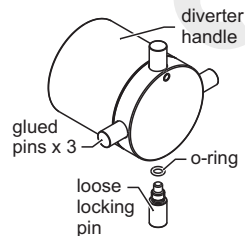

Figure 28 Lose locking pin detail. Shown on diverter handle

For both the flow control and diverter handles, remove the loose locking pin from the bottom of the handle. Slide the handle onto the brass adaptor. Maintain the orientation of the handle markings as shown in fig.29. The o-rings on the adaptor will offer some resistance (if necessary lubricate with water containing a little washing-up liquid) push past this until the handle is seated correctly on the adaptor.

As with temperature handle, the 3 locator pins visible inside the handle MUST fit into the 3 grooves cut into the brass adaptors.

When the handle is correctly seated, the loose locking pin can be screwed back into the handle. This pin should enter the hole in the brass adaptor and secure the handle to the valve.

If necessary, the brass adaptor can be rotated to achieve alignment. This is done by unscrewing the centre screw in the adaptor. The adaptor can then be pulled off. Reposition the adaptor on the drive spindle then retightening the screw

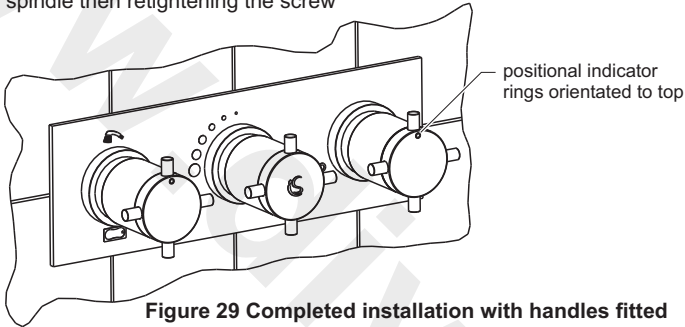

NOTE: If gaps are visible between the handles and the shrouds, the shrouds can be pulled towards the handles to close these gaps. The shrouds should be gripped by hand (perhaps rotated to start movement) and slid towards the handles (refer to section 10).

Figure 29 Completed installation with handles fitted

Where this product is being mounted vertically, the flow control adaptor should be re-positioned to maintain the logo orientation. (Rotate anti-clockwise by 90°).

To remove the trim kit in future for maintenance and servicing, use the installation information in reverse sequence...

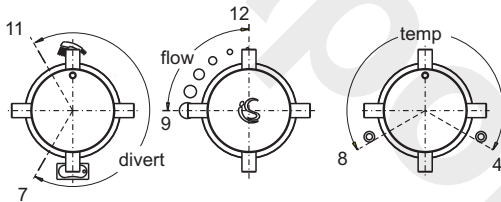

Figure 30 Handle movement range (numbers signify o'clock) for 2-way diverter

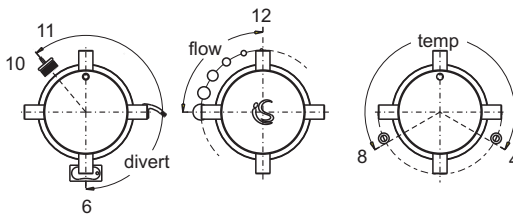

Figure 31 Handle movement range for 3-way diverter

Handle movement remains the same, regardless of whether the product is mounted horizontally or vertically. Logo handle position can be adjusted if vertical mounting is preferred

14 CONTROLS AND FUNCTIONS

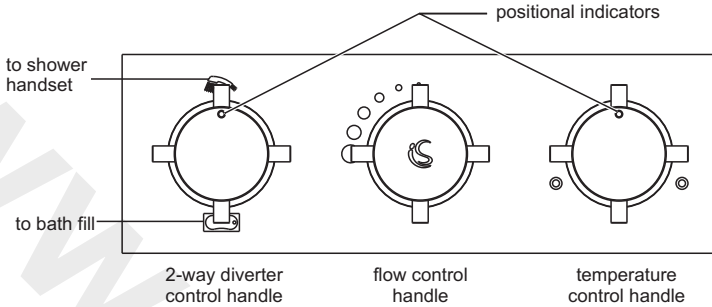

Figure 32 Quick reference to control knobs & functions for 2-way diverter (Bath Shower Mixer version shown)

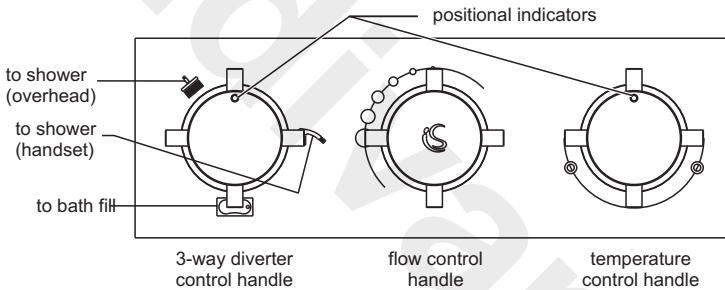

Figure 33 Quick reference to control knobs & functions for 3-way diverter

Two handles are marked with a positional indicator to establish the current setting of each control. The centre handle is marked with logo only.

1. Temperature control handle: is situated on the right hand side and is marked with small red & blue rings. This handle controls the temperature of the water flowing from the built-in valve. Rotating the handle clockwise will reduce the temperature of the water. The water is mixed by a thermostatic blending valve. The handle movement will stop just after the hot /cold markers and should not be forced beyond these points.

2. Flow control handle: is the central control. This handle controls the volume of water flowing from the built-in valve. When the logo on the handle is vertical the flow is switched off, indicated by the smallest circle symbol. Moving the handle 90° anti-clockwise, will give maximum flow as indicated by the largest circle symbol. This handle will only move a quarter of a turn and should not be forced beyond this range.

If the product is mounted vertically, this handle can be adjusted so that the logo orientation remains vertical (see section.13, and reposition adaptor on drive spindle).

3. Diverter control handle: is situated on the left hand side and is marked with symbols. These symbols represent the different types of outlets devices to which the water flowing from the built-in valve can be directed. The positional indicator shows which outlet device is currently selected. This knob is free to rotate through about 240° and should not be forced beyond this range. The movement range for the 3-way is very similar to the 2-way.

15 MAINTENANCE GENERAL

Both water supplies must be isolated before commencing any servicing work on these products.

Key working parts within the valve are in the form of replaceable cartridges. **To access these remove all trim kit parts.** (see *trim kit installation sect 9*). Handle chrome parts carefully to prevent damage. With the trim kit removed, the 3 cartridges and check valves (*shown in figure 20*) will become exposed.

For servicing the check valves, see sections 7 & 8.

TEMPERATURE CONTROL CARTRIDGE

The temperature control (thermostatic) cartridge which is situated on the right, controls the outlet water temperature. This thermostatic cartridge is protected from water borne debris by mesh filter screens, these should be checked and cleaned before contemplating replacing the cartridge.

Removal of Thermostatic cartridge: The temperature adjustment carrier (grey plastic part) can be removed by sliding the black serrated lever clockwise and pulling off. This will expose the brass handle extension which is locked to the thermostatic cartridge with two small grub screw. Use a 2.5mm Allen key to unscrew these and the extension will slide off. The thermostatic cartridge, which will then be exposed, can be unscrewed using 24mm deep socket.

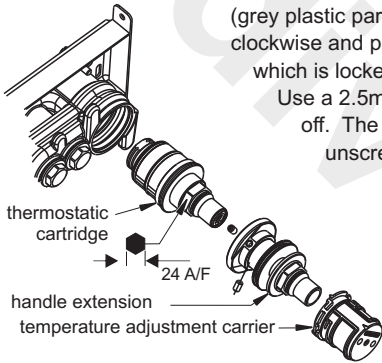

Figure 34 Moments thermostatic cartridge

To clean the screens remove the o-rings shown in Figure 35. The screens will then slide off. When clean replace the screens then the o-rings which should be lightly greased with a WRAS approved silicone grease (eg Kluber Unisilikon GBU2).

Brass adaptor can be removed from the handle carrier if necessary.



Figure 34a

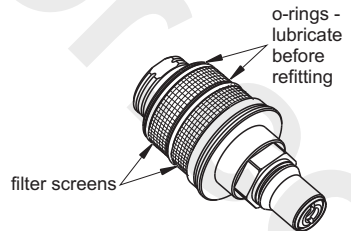
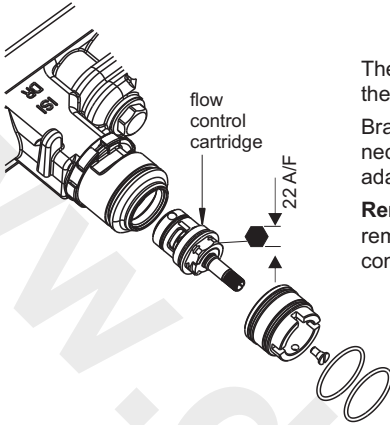

Figure 35 Thermostatic Cartridge

FLOW CONTROL CARTRIDGE



The flow control cartridge is the central control. This controls the volume of water flowing from the built-in valve.

Brass adaptor can be removed from the drive spindle if necessary. (See fig.36). If the cartridge is replaced, this adaptor should be re-fitted to the new cartridge.

Removal of cartridge: unscrew using a 22mm A/F spanner. remember to turn off water supplies before removing the flow control cartridge.

Figure 36 Flow control cartridge removal

DIVERTER CONTROL

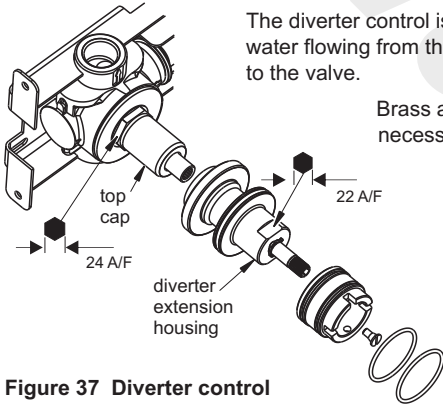

The diverter control is situated on the left hand side. This control diverts the water flowing from the built-in valve to one of the outlets devices connected to the valve.

Brass adaptor can be removed from the drive spindle if necessary. (See fig.37).

The diverter extension housing can be removed using a 22mm A/F spanner. Unscrew and remove. This will expose the top cap of the diverter. Use a 24mm deep socket to unscrew the cap. Take care as the cap is spring loaded. Most of the internal parts can be replaced (see section 16). Ensure parts are reassembled in the correct sequence.

Figure 37 Diverter control

CALIBRATION

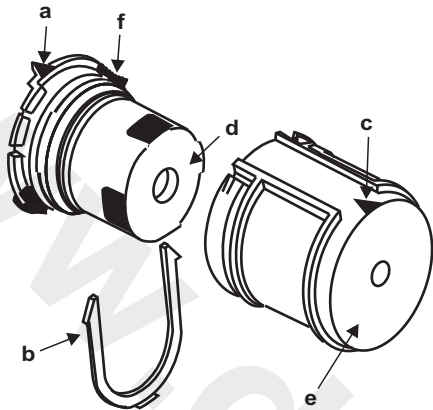

Figure 38 Temperature adjustment carrier exploded

The maximum mixed water temperature is factory set at 45°C. To change this temperature remove the temperature control handle. Remove the temperature limit stop (black H-shaped plastic part located in the temperature handle carrier) and reinsert it in the appropriate recess on the handle carrier. Four different settings are possible, 40°C, 43°C, 45°C & 50 °C (see Figure 39). Refit temperature handle.

When installing in care homes it must not be possible to deliver water hotter than 41°C so the limit stop must remain at the 40°C setting.

Remove handles, and trim kit components. Slide out the red "U" clip (b Figure 38) and disconnect the handle carrier to expose the temperature control mechanism. Turn on the shower, position a thermometer in the running water and when the temperature settles, rotate the temperature control mechanism (d) until 45 °C is achieved. Replace the handle carrier (e) ensuring the arrow (c) is at 12 o'clock. Without rotating it, refit the red "U" clip (b). Replace the covers and handles.

NOTE

Details of the recommended code of practice for safe water temperatures can be found on the Thermostatic Mixing Valve Manufacturers Association web site: www.tmva.org.uk

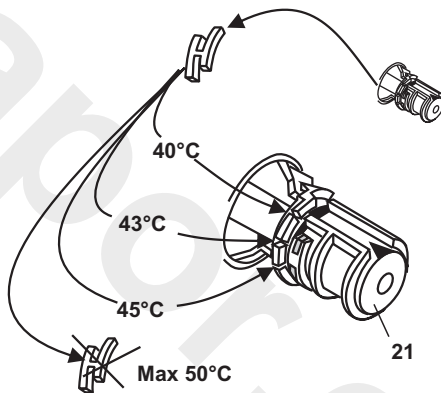

Figure 39 Adjusting the temperature limit stop

CLEANING

When cleaning the shower valve always use soap based cleaners. Never use abrasive or scouring powders and never use cleaners containing alcohol, ammonia, nitric acid, phosphoric acid organic solvents or disinfectants.

16

SPARE PARTS

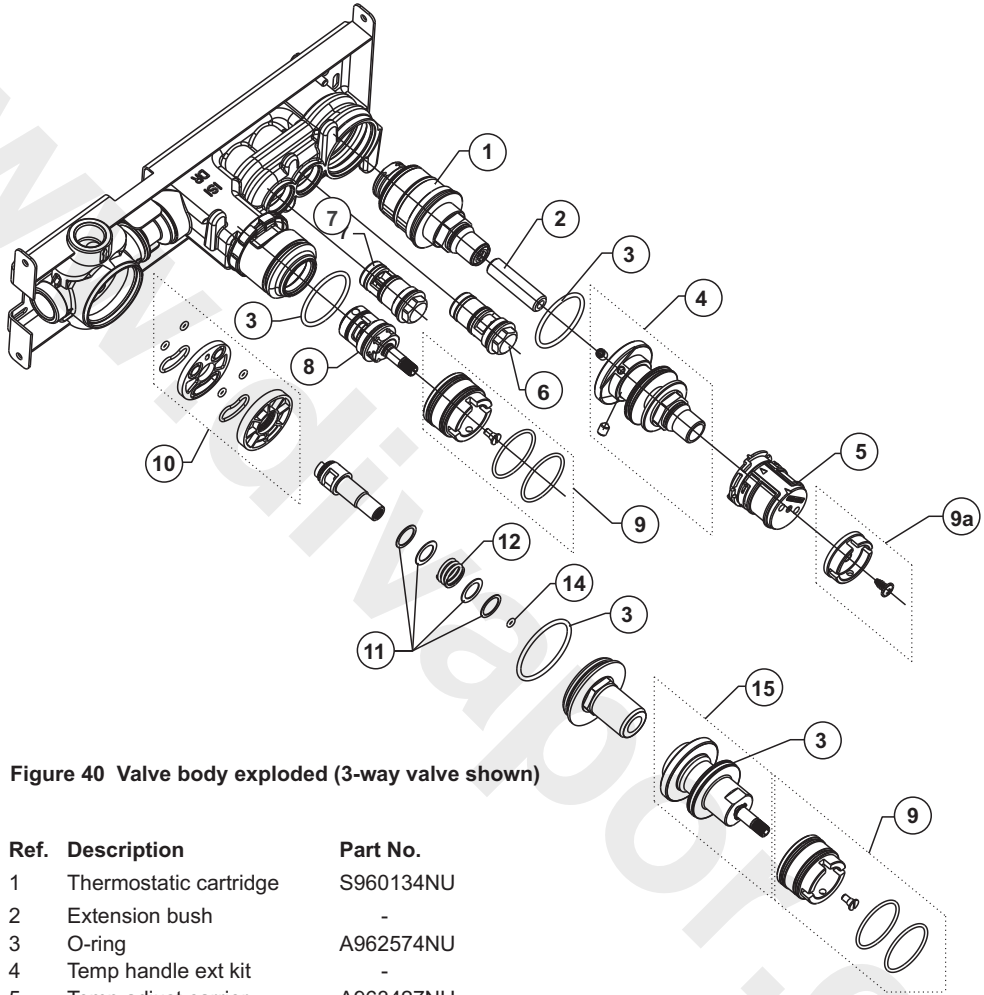

Figure 40 Valve body exploded (3-way valve shown)

Ref.	Description	Part No.
1	Thermostatic cartridge	S960134NU
2	Extension bush	-
3	O-ring	A962574NU
4	Temp handle ext kit	-
5	Temp adjust carrier	A963427NU
6	Check valve - cold	A960588NU
7	Check valve - hot	A960589NU
8	Flow control cartridge	A960462NU
9	Brass Adaptor Flow & Div	A960185NU
9a	Brass Adaptor Temp	A963198NU
10	Diverter parts kit	A963470NU
11	Washers Kit	A963471NU
12	Spring	A963472NU
14	O-ring - small	A963469NU
15	Diverter extension assy	A962320NU

16

SPARE PARTS continued

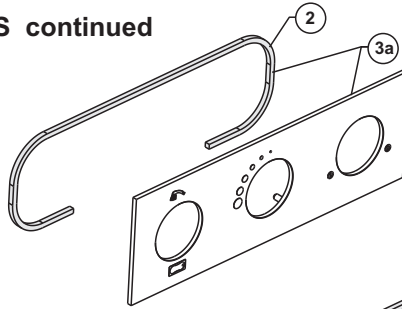

Figure 41a Oposta 2-way escutcheon from A5601AA

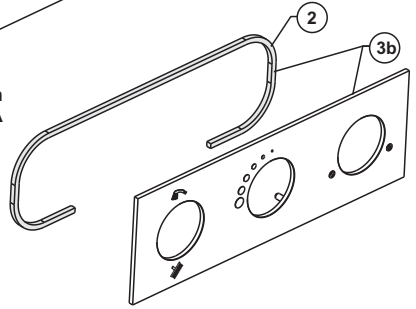
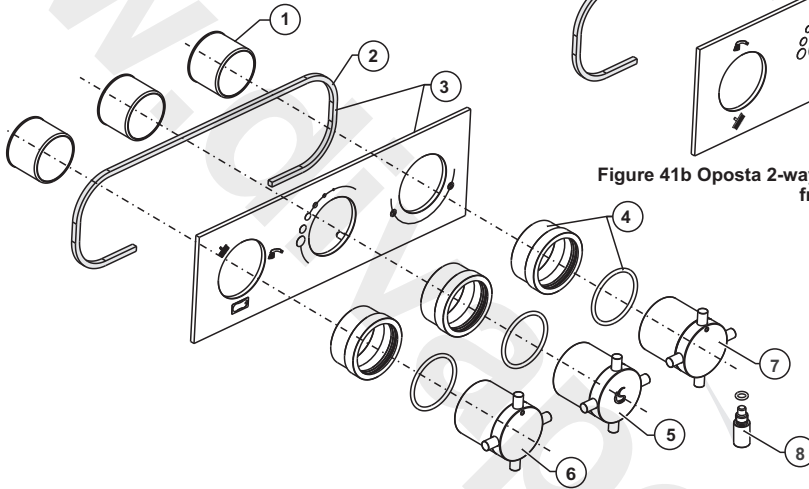

Figure 41b Oposta 2-way escutcheon from A5595AA



Ref.	Description	Part No.	Ref.	Description	Part No.
1	Short shroud	A960789AA	4	Grip ring & o-ring kit	A960791AA
2	Foam Gasket	-	5	Flow handle kit. WITH LOGO	A963202AA
3	Escutcheon & gasket 3-way	A963200AA	6	Diverter handle kit	A963201AA
3a	Escutcheon & gasket 2-way	A963199AA	7	Temperature handle kit	A963203AA
3b	Escutcheon & gasket 2-way	A963675AA	8	Loose locking pins, set of 3	A963205AA

Figure 41 Exploded view of Oposta 3-way trim kit (from A5602AA)

CUSTOMER CARE HELP LINE

0870 129 6085

CUSTOMER CARE FAX

01482 499611

E-MAIL

UKcustcare@idealstandard.com

Ideal Standard pursues a policy of continuing improvement in design and performance of its products.

The right is therefore reserved to vary specification without notice.

Ideal Standard is a division of Ideal Standard (UK) Ltd

Ideal Standard,
The Bathroom Works, National Avenue
Kingston-upon-Hull, HU5 4HS, England