

# TREVI SHOWERS



## Installation Instructions

- 325 Trevi Central Thermostat
- 486 Trevi Stop Valve
- 482 Trevi Two Way Divertor
- 582 Trevi Three Way Divertor

### INSTALLER:

*After installation please pass this instruction booklet to user*



**0870 129 6086**  
CUSTOMER CARE HELPLINE  
**01482 499611**  
CUSTOMER CARE FAX

Trevi Showers pursues a policy of continuing improvement in design and performance of its products. The right is therefore reserved to vary specification without notice. Trevi Showers is a division of American Standard Plumbing (UK) Ltd

T1101 09/02

E969900

Trevi Showers  
The Bathroom Works  
National Avenue  
Kingston-upon-Hull  
HU5 4HS England

**Figure 1 Typical 2-way divertor based system.**  
Note that two outlets cannot be operated at the same time

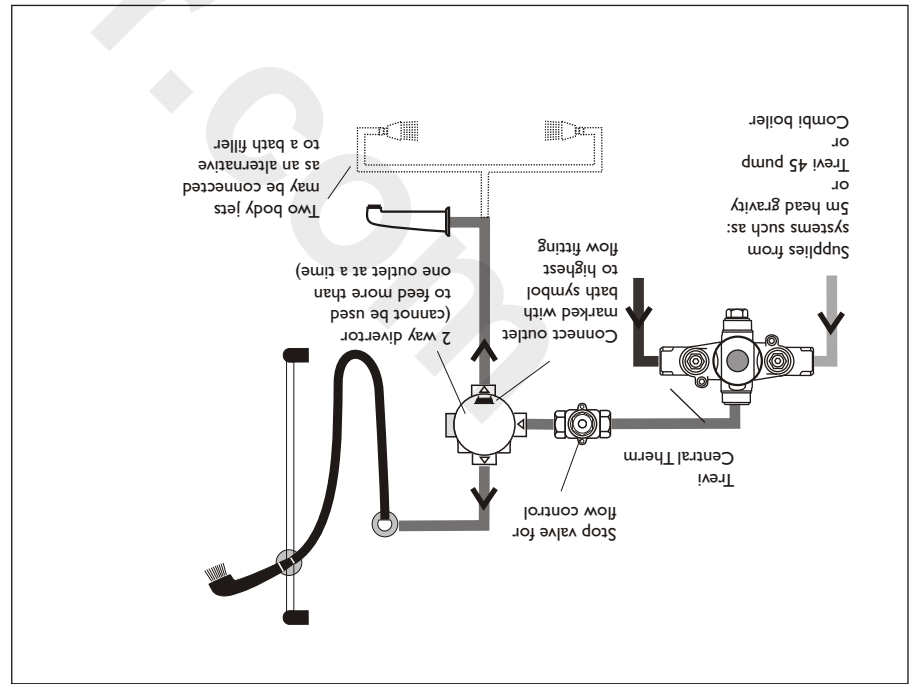

This installation instruction covers the Trevi Central Therm thermostatic valve and associated flow control valves such as stop valves and multi-function divertors. These valves are intended for built-in installation and are therefore, only suitable for concealed pipework. This equipment is normally used to supply temperature controlled mixed water to multiple outlet shower systems such as fixed overhead sprays, flexible shower kits, body jets and/or rim or wall mounted spouts for bath control (See Figs 1 & 2)

## 2 & 3 WAY DIVERTER

Ref.	Description
D1	Trevi therm handle cap
D2	Handle fixation screw
D3	Trevi therm divertor handle
D4	Handle carrier
D5	Escutcheon holder and extension spindle
D6	Escutcheon ring
D7	Plaster guard
D8	'O' ring (large)
D9	'O' ring (small)
D10	Fibre washers
D11	Spring
D12	Divertor working components kit complete
D13	Symbols/transfers

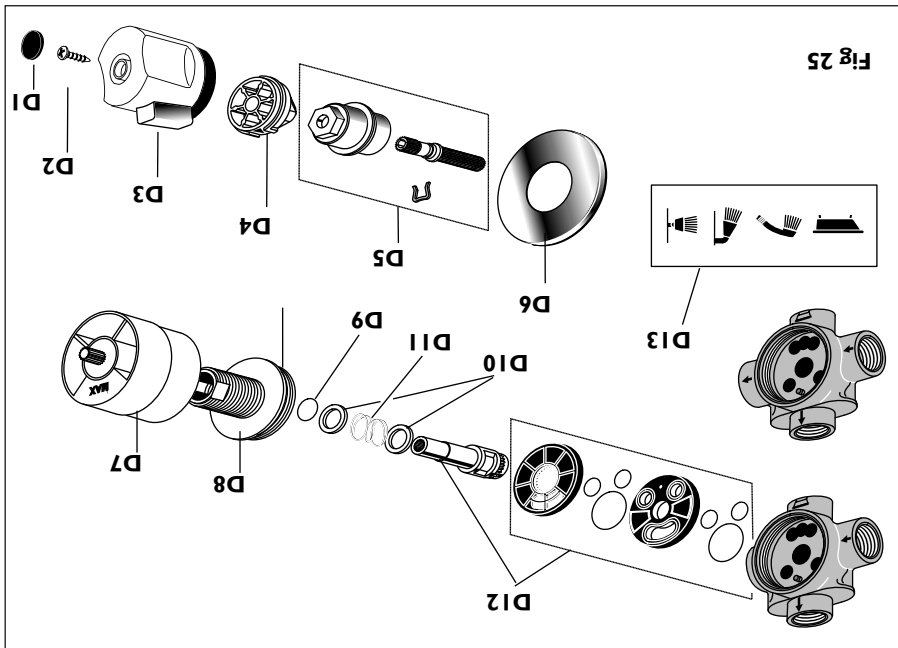

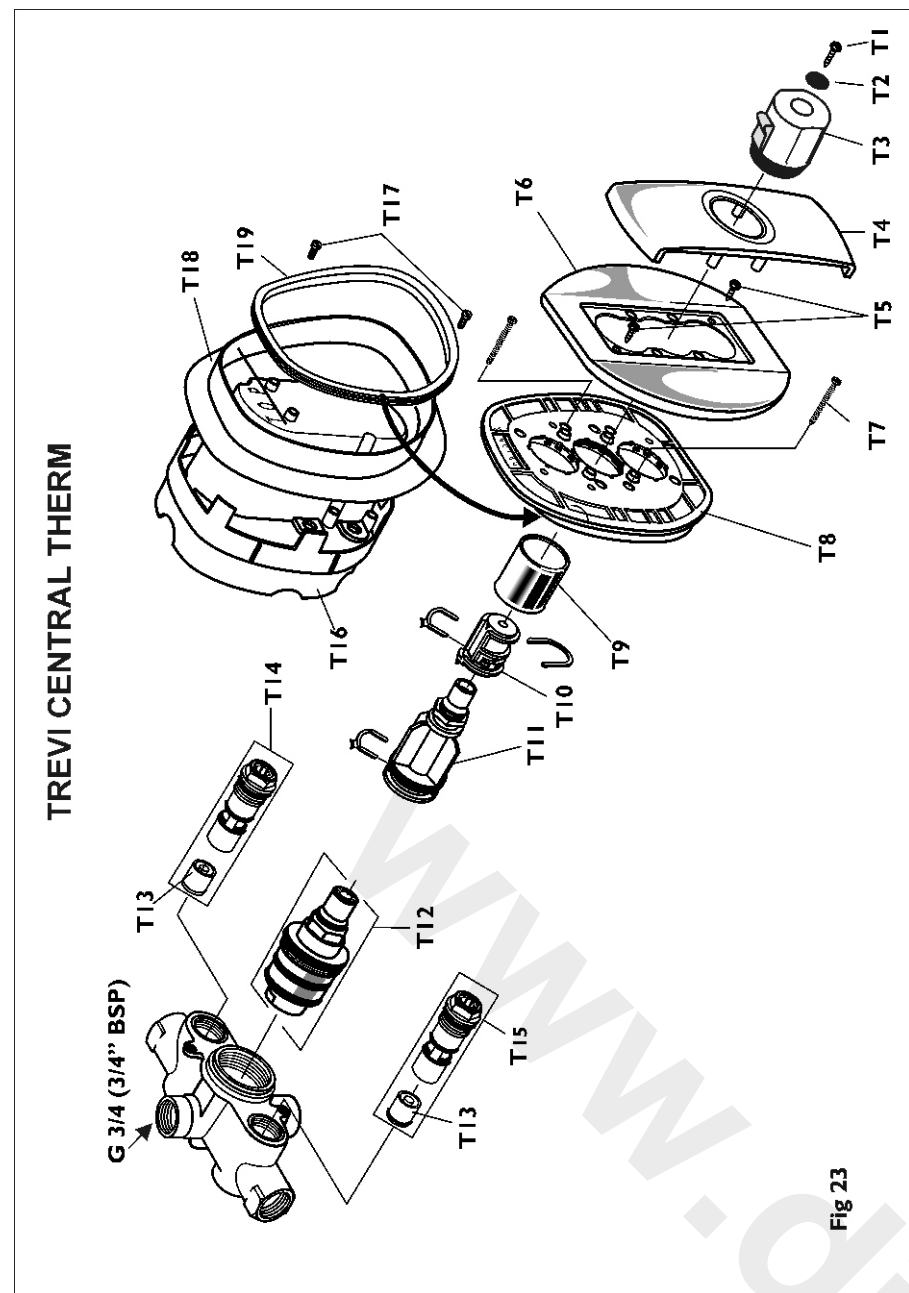

Fig 23

**WATER SUPPLIES**

The Trevi Central Therm is suitable for installation on low pressure (open vented) plumbing systems although the flow of water will only be suitable for one function i.e. overhead or flexible kit.

When multiple outlets are required a suitable booster pump should be installed.

Alternatively a high pressure system may be used such as a primary heat store or a pressurised unvented storage supply system. Instantaneous water heaters may also be used but care is required to ensure the flow rate will match the system requirements. There are some higher capacity heaters available but the most common sizes would not be suitable for a multi-bodyjet system.

**WATER REGULATIONS**

Hot and cold water supply pressures must be reasonably balanced and from a common source - both from storage or both from a supply pipe.

The valve will function within specification on unequal pressures up to a ratio of 5:1, but it is not recommended that the cold supply be connected to the rising main and hot to the tank fed supply as the pressure differential is likely to exceed the 5:1 ratio. The minimum pressure for correct operation is 0.1 bar (1m head). Pressure head is measured as the vertical distance between the bottom of the cold water storage tank which feeds the hot water system and the highest point on the shower spray plate. When installing with a shower pump the use of a secondary tapping from

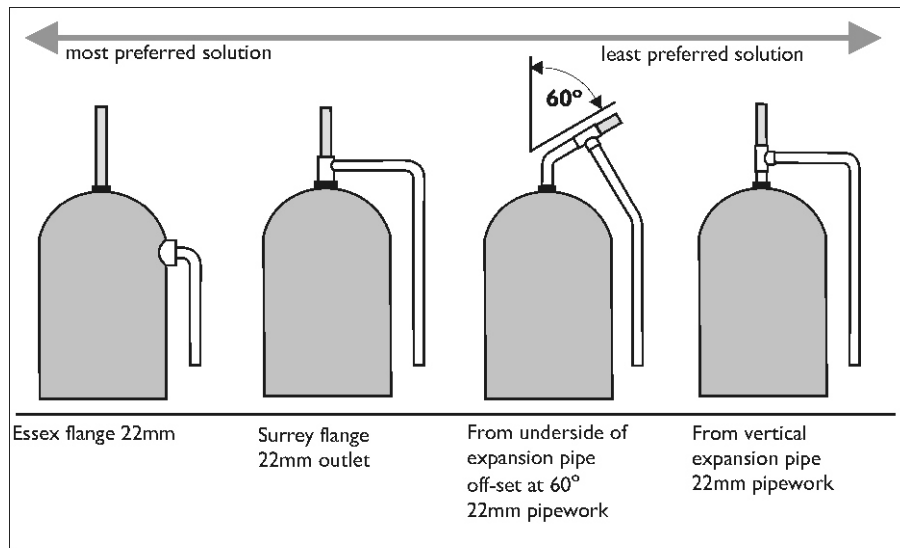

Fig 4 Preferred location of cylinder tapping

**Table 1 Types of outlets which can be supplied by a diverter connected to various different hot water systems.**

Hot water system	Bath filler	2 body jets	4 body jets	6 body jets	Flexible kit	Fixed over-head shower head	4 body jets + over-head	2 body jets + over-head
Unvented hot water system	✓	✓	✓	✓	✓	✓	✓	✓
Domestic Combi Boiler	✓	✓	✓	✓	✓	✓	✓	✓
High Capacity Combi Boiler	✓	✓	✓	✓	✓	✓	✓	✓
Gravity system 1m head					✓	✓	✓	✓
Gravity system 3m head					✓	✓	✓	✓
Gravity system 5m head					✓	✓	✓	✓
Trevi 45 pump system	✓	✓	✓	✓	✓	✓	✓	✓
Trevi 3 bar pump system	✓	✓	✓	✓	✓	✓	✓	✓

✓ - will perform satisfactorily  
 ✗ - performance not guaranteed

Figure 2 Typical 3-way diverter based system. Note that two or more outlets cannot be operated at the same time.

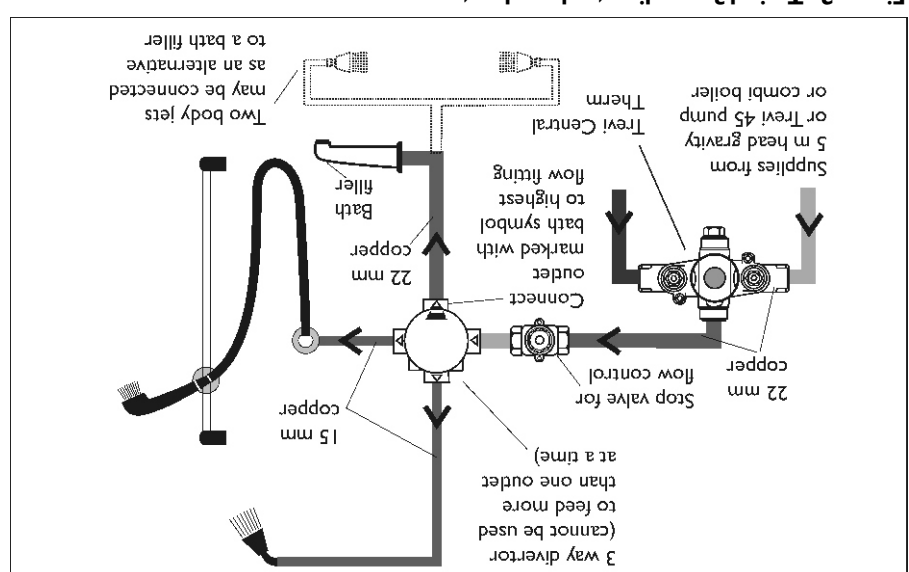

- S1 Trevi handle cap
- S2 Handle fixation screw
- S3 Trevi handle
- S4 Handle carrier
- S5 Escutcheon
- S6 Fixation screws (pair) (M4 x 57 mm)
- S7 Escutcheon holder
- S8 Extension spindle (65 mm)
- S9 3/4" Rubber valve
- S10 Stop valve body
- S11 Plaster guide
- S12 Plaster guide fixation screws

**STOP VALVE**

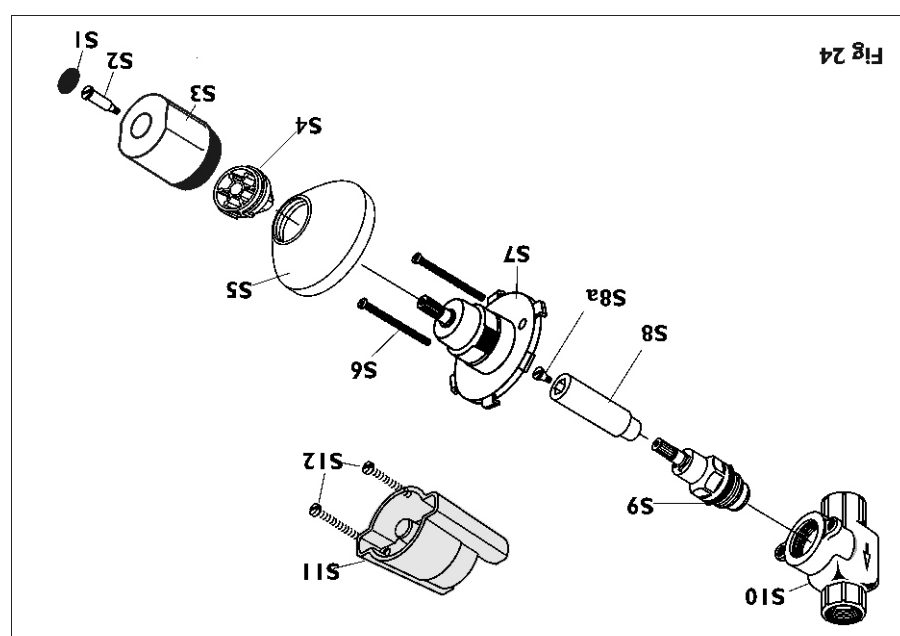
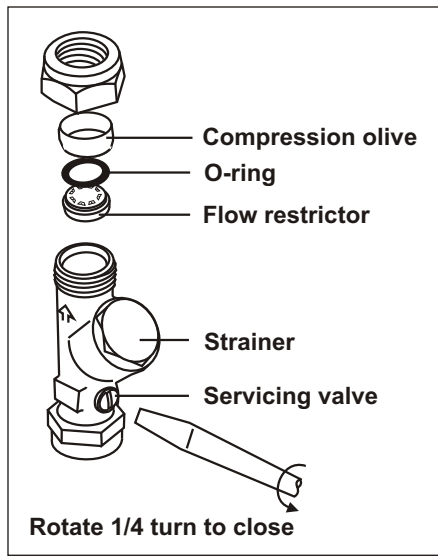

Fig 24

the cylinder is highly recommended. Figure 4 shows the various methods of connecting the hot water pipe to the cylinder - the most preferred on the left and the least preferred on the right. Shower pumps must never be installed on the mains supply pipe. The valves and pipework should be so installed as to be readily accessible for examination, repair, replacement or operation. Isolation valves should be fitted on the incoming water supply to the mixer valve. The temperature of the hot water must not exceed 85°C but the installer's attention is drawn to code of practice BS 6700 which recommends that stored hot water should normally never exceed 65°C. For correct operation of the valve, a minimum of 52°C is required.

**COMBINATION BOILERS**

When installing on a modulating combination boiler it is sometimes possible for the interaction of a thermostatic valve with the combi to cause the boiler to cut out and cut in again with the result that the water will become alternatively cold and hot. To overcome this, flow restrictors can be fitted upstream of the thermostatic valve. As an optional extra Trevi Showers can supply in-line strainers/servicing valves which include these flow restrictors. These should be inserted in the downstream side of the servicing valve as shown on Fig 5. It is essential that they are positioned the right way round as shown in the sketch. Remove the compression nut and olive from



**Fig 5 Servicing valve showing flow restrictor**

the outlet side of the servicing valve and place the restrictor in the outlet. Push to the bottom of the recess. Fit O-ring in the visible rebate around the edge of the restrictor and push home until it is fully in the rebate. Use the tip of a small screwdriver or similar to achieve this.

The water regulations published in 1999\* take a new approach to backflow in that they look at different categories of risk. The installer must assess the risk from the various categories of fluid in adjacent appliances before determining the level of backflow protection required for a particular installation. Figures 6 & 7 outline the protection required in various installations.

\*A guide to the Water Supply (Water fittings) Regulations 1999 and the Water Byelaws 2000, Scotland is published by WRAS (Water Regulations Advisory Scheme) Fern Close, Pen-y-Fan Industrial Estate, Oakdale, Newport, NP11 3EH. ISBN 0-9539708-0-9.

**CALIBRATION**

Trevi thermostats are factory calibrated and require no further calibration during installation. However, if the temperature adjustment carrier is accidentally disturbed and the calibration altered it is a simple

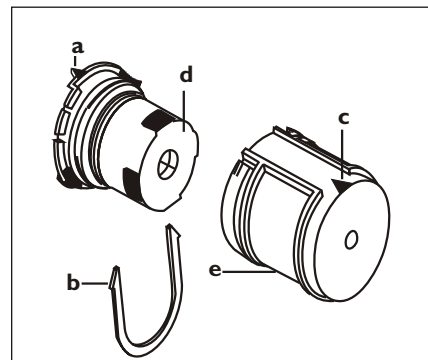

**Fig 22**

procedure to recalibrate the unit. Before starting this you will need to ensure the hot supply temperature is above 52°C. You will need a thermometer

1. Remove the temperature control handle.
2. Remove the red U-clip (b) from the temperature adjustment carrier. (Fig22)
3. Remove the front carrier (e).
4. Rotate the temperature adjusting spindle (d) until a temperature of 40°C is measured at the outlet.
5. Replace the front handle carrier ensuring the triangular mark (c) is to the top.
6. Refit the red U-clip.
7. Refit the temperature handle.

**MAXIMUM TEMPERATURE STOP**

The maximum mixed water temperature is factory set at 45°C. To change this temperature remove the temperature control handle. Remove the temperature limit stop (black H-shaped plastic part) and re-insert it in the appropriate recess on the handle carrier. Four different settings are possible. 40°C, 43°C, 45°C & 50°C (See fig 23) Refit temperature handle. When installing in care homes it must not be possible to deliver water hotter than 41°C so the limit stop must be placed in the 40°C position. Details of the recommended code of practice for safe water temperatures can be found on the Thermostatic Mixing Valve manufacturers Association web site: www.tmva.org.uk

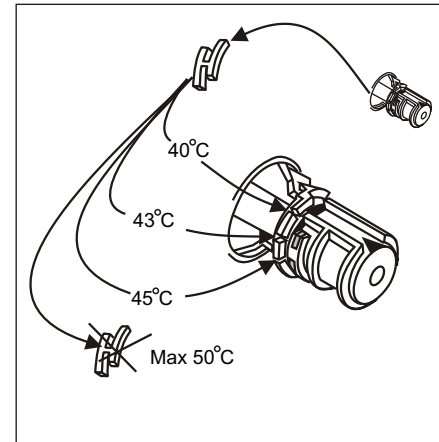

**Fig 23 Setting the maximum temperature limit stop**

**TREVI CENTRAL THERM**

Description	Ref
Trevi temperature control handle cap	T1
Temperature control handle screw	T2
Trevi temperature control handle	T3
Front cover plate	T4
Face plate fixation screws	T5
Rear cover plate	T6
Escutcheon cover fixation screws	T7
Escutcheon cover plate	T8
Shroud	T9
Temperature adjustment carrier	T10
Temperature Carrier Extension	T11
Thermostatic Cartridge	T12
Non-return valve	T13
Cold non-return valve assembly	T14
Hot non return valve assembly	T15
Plaster guard	T16
Plaster guard screws M4 x 10	T17

**Figure 3 Typical stop valve based system.**  
Note that Overhead spray and body jets can be operated at the same time

**Table 2 Types of outlets which can be supplied by a stop valve system connected to various different hot water systems.**

Hot water system	2 body jets	4 body jets	6 body jets	flexible kit	Fixed shower head	6 body jets + shower head	4 body jets + shower head	2 body jets + shower head	Unvented H/W system	Domestic Combi Boiler	High Capacity Combi	Gravity system 1m head	Gravity system 3m head	Gravity system 5m head	Trevi 45 pump system	Trevi 3 bar pump system
Hot water system	✓	✓	✓	✓	✓	✓	✓	✓	✓	✓	✓	✓	✓	✓	✓	✓
Unvented H/W system	✓	✓	✓	✓	✓	✓	✓	✓	✓	✓	✓	✓	✓	✓	✓	✓
Domestic Combi Boiler	✓	✓	✓	✓	✓	✓	✓	✓	✓	✓	✓	✓	✓	✓	✓	✓
High Capacity Combi	✓	✓	✓	✓	✓	✓	✓	✓	✓	✓	✓	✓	✓	✓	✓	✓
Gravity system 1m head	✓	✓	✓	✓	✓	✓	✓	✓	✓	✓	✓	✓	✓	✓	✓	✓
Gravity system 3m head	✓	✓	✓	✓	✓	✓	✓	✓	✓	✓	✓	✓	✓	✓	✓	✓
Gravity system 5m head	✓	✓	✓	✓	✓	✓	✓	✓	✓	✓	✓	✓	✓	✓	✓	✓
Trevi 45 pump system	✓	✓	✓	✓	✓	✓	✓	✓	✓	✓	✓	✓	✓	✓	✓	✓
Trevi 3 bar pump system	✓	✓	✓	✓	✓	✓	✓	✓	✓	✓	✓	✓	✓	✓	✓	✓

Legend: ✓ - will perform satisfactorily; ✗ - performance not guaranteed

### FINAL ASSEMBLY

Remove the plaster guard.

Fit the extension spindle (S8) to the stop valve using the small screw (S8a). Shorten the extension spindle (S8) so that it projects only 36mm from the finished wall surface. The plaster guard (S11) has a mark which allows it to be used as a gauge (Fig 14)

Secure the extension spindle (S8) and the escutcheon holder (S7) to the valve using the 57mm screws (S6). These may need to be cut depending on the build in depth.

Push on the wall escutcheon (S5).

Fit the handle carrier (S4).

Fit the handle (S3).

Check for correct operation.

connection otherwise the divertor will malfunction. (Figs 1 & 2)

### Warning

**Do not seal any outlet connections on the divertor as this will damage the fitting select the correct version for the job. A three way cannot be converted to a two way.**

The build-in depth from the finished wall surface to the centre of the pipework is in the range 41mm – 66mm (these are also marked on the plaster guard see Fig 17) but consideration should be given to the build-in depths of the other valves in the system and if possible a depth selected which will be common to all of them - (Table 3)

Remember to remove plaster guard (D7) by rotating clockwise and test for leaks before completing the plastering

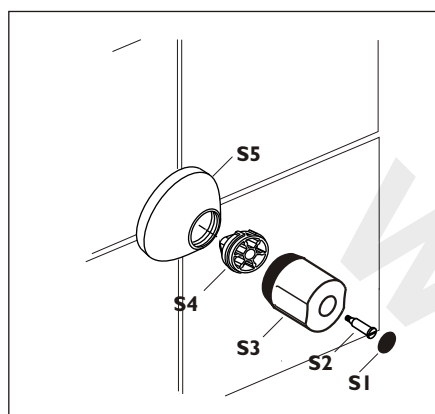

Fig 16 Fit stop valve handle

### INSTALLATION OF TWO & THREE WAY DIVERTORS

Connections to the multi-function divertor bodies are 1/2" BSP female. The mixed water from the Central Therm must be connected to the inlet

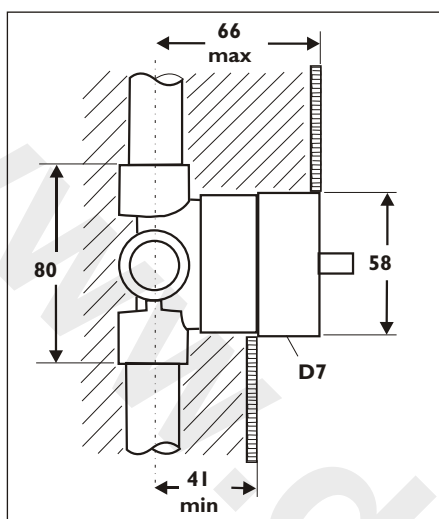

Fig 17 Divertor dimensions 2 & 3 way

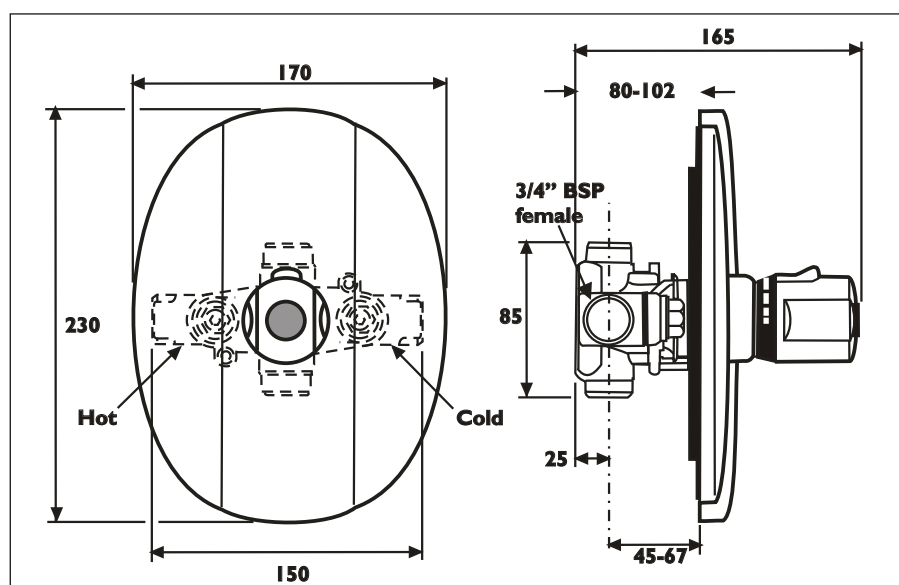

Fig 8 Trevi Central Therm showing dimensions and build-in depth

the wall construction but it is useful to consider the depth requirements of the associated control valves (Table 3)

**Do not solder close to the valve bodies as the heat will damage the internal components**

Once all the connections to the valves are complete test for leaks before final reinstatement of the wall and tiling.

Valve	Minimum	Maximum
Central Therm	45 mm	87 mm
Stop Valve	39 mm	84 mm
Divertor	41 mm	66 mm

Table 3 Build-in depths

The integral isolation/non-return valves are supplied in the open position. Rotate the temperature control handle both clockwise and anti-clockwise to pressure test the connections. When plastering is complete fix the sealing frame (T18) to the wall using tile adhesive. (Fig 9)

Leave plaster guard (T16) in position to protect the fitting and complete tiling. Ensure tiles cover the wall flange of the sealing frame. (Fig 10)

Remove the plaster guard (T16) and trim back the sealing frame (T18) to the tile surface using a sharp knife. (Fig 11) Connect the rubber seal (T19) to the escutcheon cover plate (T8)

Place the escutcheon cover plate over

Fig 6 Illustration of backflow risk from a fluid Category 3 risk

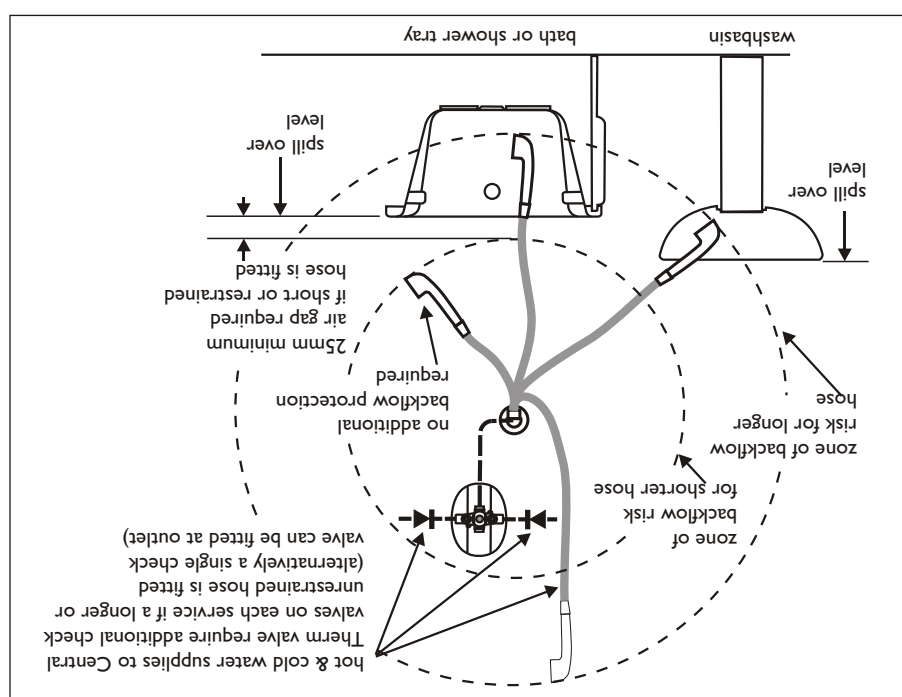

Water in a shower tray, basin or bathtub is considered to be a fluid category 3 risk which is a fluid which represents a slight health hazard if it were to find its way back into the supply pipe. For this reason it must not be fitted to the inlet on both hot and cold supplies to the thermostatic valve. Alternatively an additional check valve should be fitted in the valve outlet. No additional check valves need be fitted if the hand spray is prevented from reaching closer than 25mm of the spill over level of any such fixture.

### CATEGORY 5 RISK

Water in a sink, WC, bidet or bath used in health care is considered to be a fluid category 5 risk which is a fluid which represents a serious health hazard if it were to find its way back into the supply pipe. For this reason it must not be used inside say a bathtub or a basin it is essential that additional check

appropriate protection is employed. If it is desired to allow the hand spray to be able to enter any adjacent washbasin, bath or shower tray unless head to be able to enter any adjacent washbasin, bath or shower tray unless

be possible for any flexible shower head to be able to enter any adjacent washbasin, bath or shower tray unless appropriate protection is employed. If it is desired to allow the hand spray to be able to enter any adjacent washbasin, bath or shower tray unless head to be able to enter any adjacent washbasin, bath or shower tray unless

### CATEGORY 3 RISK

Water in a shower tray, basin or bathtub is considered to be a fluid category 3 risk which is a fluid which represents a slight health hazard if it were to find its way back into the supply pipe. For this reason it must not be possible for any flexible shower head to be able to enter any adjacent washbasin, bath or shower tray unless

Fig 21 Thermostatic cartridge

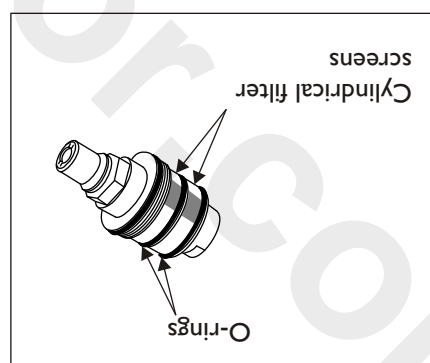

1. Isolate the valve from the supply for this operation.  
2. Remove handle (T3 - Fig 23)  
3. Remove the front cover plate (T4) by prising forward using the small slots at the sides of the front cover plate.  
4. Remove the two cover plate screws (T5) and pull off the back cover plate (T6)  
5. Remove shroud (T9) by pulling carefully forward.  
6. Remove the temperature adjustment carrier (T10) by rotating the black locking latch and pulling forward.  
7. Remove the rear temperature handle extension (T11) by rotating the black locking latch and pulling forward. The thermostatic cartridge (T12) can now be removed by turning anticlockwise.  
8. The thermostatic cartridge (T12) can now be removed by turning anticlockwise.  
9. It is usually unnecessary to fit a new thermostatic cartridge. Most problems occur because debris from the pipe work has blocked the cartridge filter screens.  
10. The cylindrical filter screens can be removed for cleaning by removing the O-rings from the cartridge and sliding the screens off. (Fig 21) Do not attempt to refit the cartridge with the filter screens missing. Any small particles of grit in the water supply will cause the mechanism to jam. (Place all components which have grease on them on a clean piece of paper to avoid picking up grit)  
11. Refit cartridge O-rings and lubricate with silicone grease.

### THERMOSTAT REPLACEMENT

1. Isolate the valve from the supply for this operation.  
2. Remove handle (T3 - Fig 23)  
3. Remove the front cover plate (T4) by prising forward using the small slots at the sides of the front cover plate.  
4. Remove the two cover plate screws (T5) and pull off the back cover plate (T6)  
5. Remove shroud (T9) by pulling carefully forward.  
6. Remove the temperature adjustment carrier (T10) by rotating the black locking latch and pulling forward.  
7. Remove the rear temperature handle extension (T11) by rotating the black locking latch and pulling forward. The thermostatic cartridge (T12) can now be removed by turning anticlockwise.  
8. The thermostatic cartridge (T12) can now be removed by turning anticlockwise.  
9. It is usually unnecessary to fit a new thermostatic cartridge. Most problems occur because debris from the pipe work has blocked the cartridge filter screens.  
10. The cylindrical filter screens can be removed for cleaning by removing the O-rings from the cartridge and sliding the screens off. (Fig 21) Do not attempt to refit the cartridge with the filter screens missing. Any small particles of grit in the water supply will cause the mechanism to jam. (Place all components which have grease on them on a clean piece of paper to avoid picking up grit)  
11. Refit cartridge O-rings and lubricate with silicone grease.

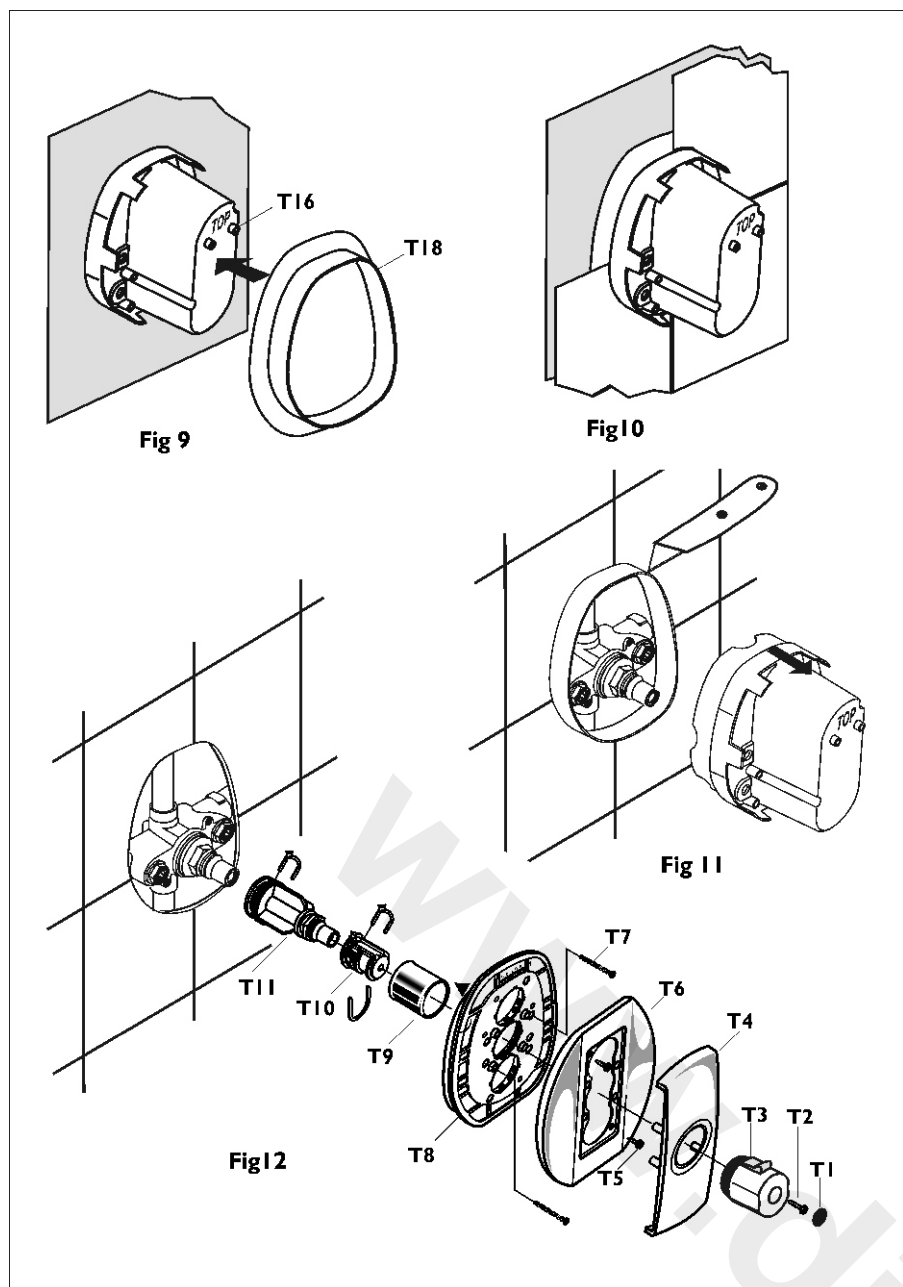

the shroud (T9) and secure to the Central Therm body using screws (T7)  
Fit the rear cover plate (T6) using the fixation screws (T5)  
Snap on the front cover plate (T4) (ensure the water seal is to the top)

**INSTALLING STOP VALVE**

Connections to the stop valve are 3/4" BSP female. The incoming mixed water must be connected to the inlet of the stop valve. (Fig 13) Plumbing for all mixed water pipework should be in 22mm copper.

The build-in depth from the finished wall surface to the centre of the pipework is in the range 39mm - 84mm (these are also marked on the plaster guard see Fig 14) but consideration should be given to the

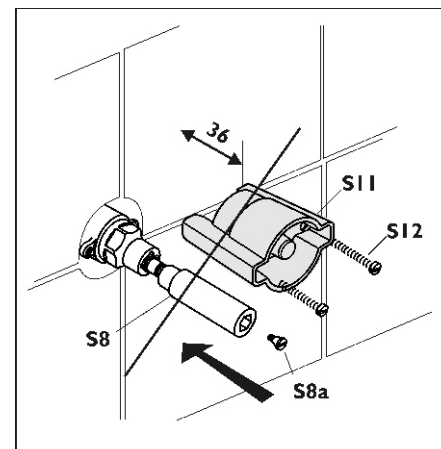

Fig 14 Fitting spindle extension

build-in depths of the other valves in the system (see Table 3)  
Remember to remove plaster guard (S11) and test for leaks before completing the plastering and tiling. Replace the plaster guard (S11) and complete the plastering and tiling.

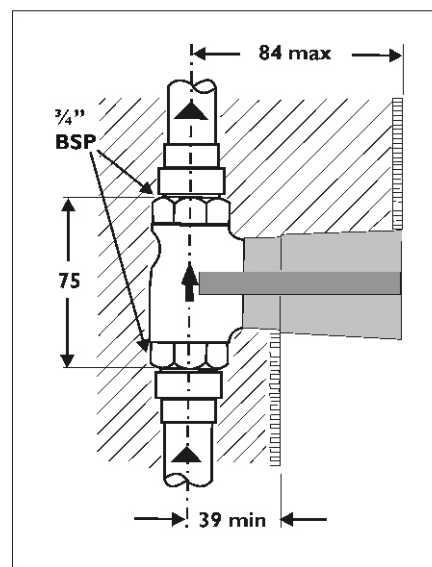

Fig 13 Stop valve dimensions

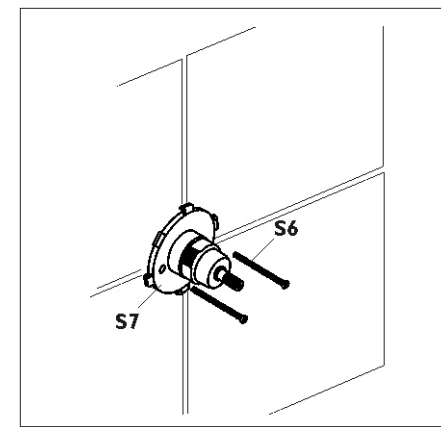
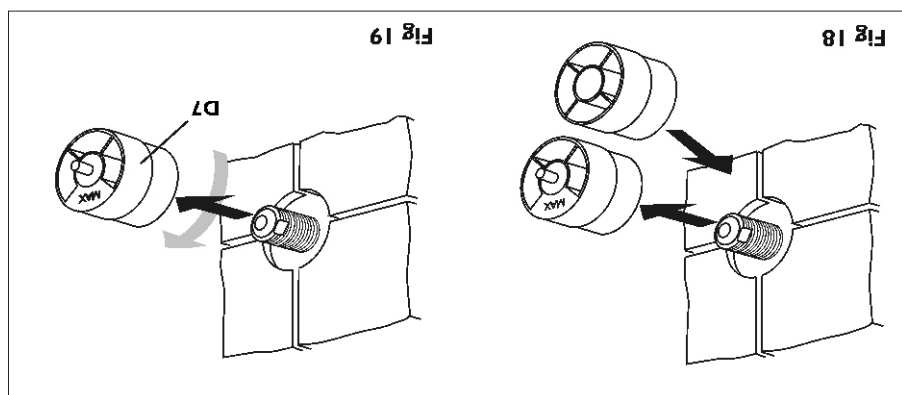
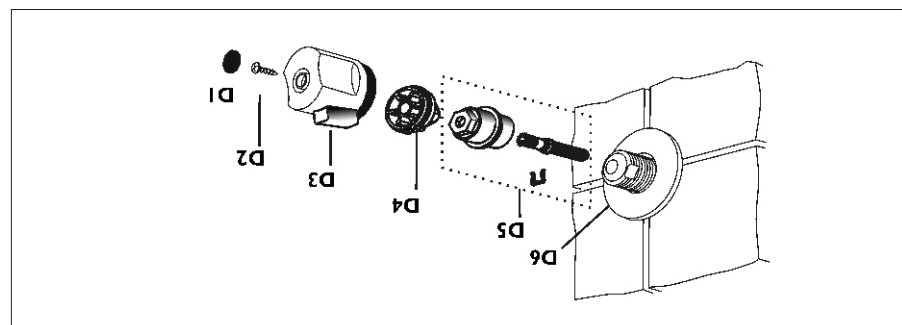

Fig 15 Fit stop valve escutcheon holder

The Trevi Central Therm is fitted with a temperature over-ride button. Sliding the button and rotating the temperature handle further in an anti-clockwise direction. Normally this is pre-set to limit the temperature to 40°C. However, higher temperatures may be obtained by

**TEMPERATURE OVER-RIDE BUTTON**

Fig 20 Divertor handle assembly



The splined pin on the front of the plaster guard can be used to operate the valve when testing (Fig 18) and replace the plaster guard (D7) and spindle to the flow to bath position and spindle to the flow to bath position and fit the handle carrier (D4) with the arrow at 12 o'clock. After tiling is complete remove the plaster guard (D7) by rotating clockwise. (Fig 19) Fit the handle (D3) and secure with fixation screw (D2). Push on handle cap (D1). Place the escutcheon plate (D6) into

It is essential to ensure that the water supply pipes for the hot and cold water are connected to the correct inlets on the valve body - see Fig 8  
Ensure that the "TOP" marking on the plaster guard is at 12 o'clock. The Trevi Central Therm is designed to be recessed into the wall to a depth in the range 80mm to 102mm. This is measured from the back surface of the valve body to the finished wall surface (including tiling where appropriate). This gives 45mm - 67mm build-in depth from the centre of the pipework to the wall surface. The build-in depth to select will depend on

**INSTALLATION OF MIXER VALVE**

Fig 7 Illustration of backflow risk from a fluid Category 5 risk

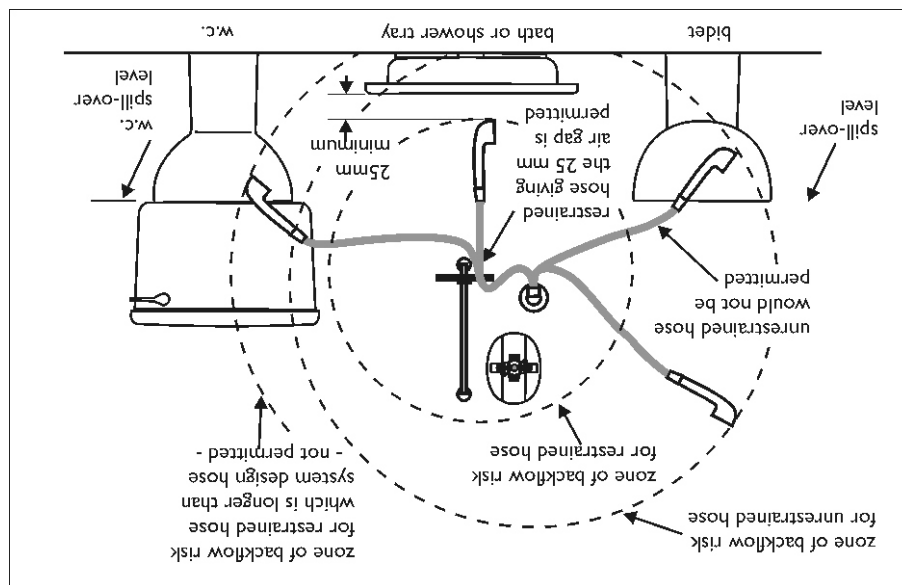

It will also be seen that this risk could change should the hose be taken out of the restraining device or should a longer replacement hose be fitted at a later date. Installers and householders are advised to take account of these factors when fitting replacement hoses. For pumped applications the pipe supplying the pump must not also supply an ascending spray bidet. It is possible for any flexible shower head to be able to enter any adjacent sink, WC, bidet or bath used in health care. (Fig 7) If the flexible hose to be fitted could reach into any such vessel, the requirements to the system design are so onerous it is better not to fit a flexible. Rather, a fixed overhead showerhead should be considered.