

Armitage Shanks

INSTALLATION INSTRUCTIONS

Sensorflow 21 panel mounted 150 & 230 reach spouts with remote sensor

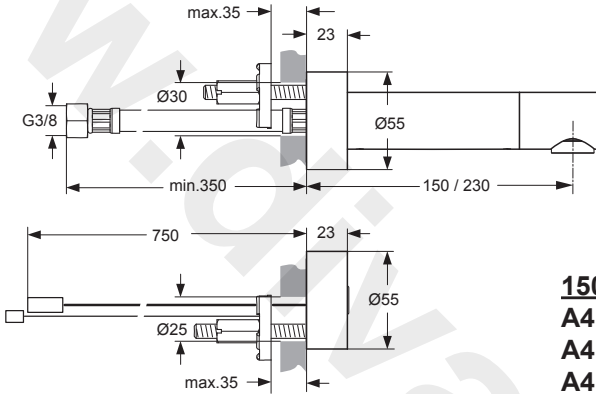

150 Reach:
A4126AA,
A4180AA &
A4181AA

230 Reach:
A4182AA,
A4183AA &
A4184AA

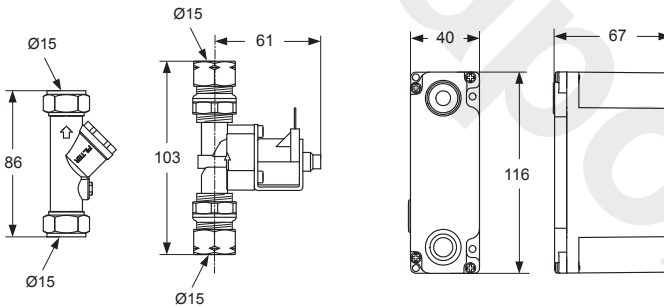

Important:

- 1. Electrical connection:** mains electric powered versions of these products must be connected to a continuous permanent power supply.
- 2. Sensor protector:** this black-out lens cover should only be removed from the sensor after completing installation & at least 20 seconds after powering up.

See page 3 for more details.

IMPORTANT

BEFORE CONNECTION, FLUSH WATER THROUGH PIPEWORK TO REMOVE ALL DEBRIS ETC. WHICH COULD DAMAGE THE VALVE MECHANISM

INSTALLER: After installation please pass this instruction booklet to user

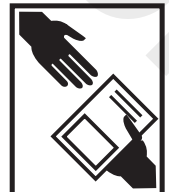

TABLE OF CONTENT

1	IMPORTANT PRE-INSTALLATION NOTES	3
2	PRODUCT BOX CONTENTS	4
3	SUPPLY CONDITIONS.....	5
4	WATER REGULATIONS	5
5	INSTALLATION GUIDE.....	6
5.1	MOUNTING	6
5.2	PLUMBING OVERVIEW.....	7
5.3	ELECTRICAL CONNECTION.....	9
6	TAP OPERATION.....	14
7	SENSOR RANGING	15
8	OUTLET OPTIONS.....	16
9	MAINTENANCE	16
9.1	SOLENOID VALVE	16
9.2	HYGIENE FLUSH (AUTOMATIC).....	17
9.3	ISOLATING VALVE.....	18
10	SPARE PARTS.....	19
11	CLEANING CHROME SURFACES	20



Sensorflow 21 panel mount spout with remote sensor

These panel mount Sensorflow 21 electronic products are designed for water economy & hygienic “no-touch” operation.

The spout is operated by the remote infrared sensor which is triggered by hand movement in the sensing region. When the hands are moved away, the water will stop automatically within a couple of seconds.

These products are designed to be supplied with pre-mixed or cold water.

The two designs 150 & 230mm reach are each available in 3 versions: Mains powered (transformed) with option to link up to 5 link units & independent battery powered units:

A4126AA (150) & **A4182AA** (230) are supplied with **battery unit**

A4180AA (150) & **A4183AA** (230) are supplied with **mains power unit**

A4181AA (150) & **A4184AA** (230) are supplied with **link unit**

(Link up to 5 per A4180AA or A4183AA)

1 IMPORTANT PRE-INSTALLATION NOTES



MAINS ELECTRICAL POWER SUPPLY

Mains powered Sensor Operated Products must be connected to a (fused / switched) **continuous permanent power supply**.

Connection to an **interrupted power supply** intended to stop electrical consumption in an unused facility, may adversely affect this sensor product and is therefore not recommended.

Each time the power supply is reinstated the product briefly enters reprogramming mode.

During reprogramming mode, any interaction (passive or active) with the product may alter the sensor settings in respect to range and / or run duration.

No significant savings will be achieved by connection to an interrupted supply. These products are intrinsically economical in terms of both water and electrical energy and will shut down in the event of a sensor being obstructed.

SENSOR PROTECTIVE COVER

This product is supplied with the sensor lens covered over with a black-out material.

DO NOT REMOVE this lens cover until the product installation has been completed & then wait for at least 20 seconds after powering-up.

The lens cover prevents the sensor from being unintentionally reprogrammed during the powering up sequence.



Don't
remove, read
instruction 1st

**DURING SETTING UP PROCEDURE
AVOID HIGH VISIBILITY CLOTHING**



2 PRODUCT BOX CONTENTS

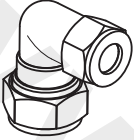

1x Inlet elbow
15 to 10mm
compression

2x Couplers
G 1/2" female
thread to
15 mm
compression

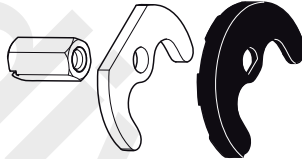
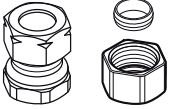

2x Spout mounting kit

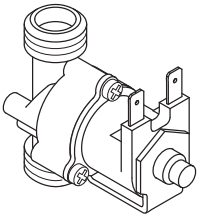

1x Solenoid valve

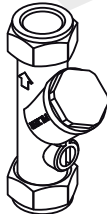

1x Inline service valve with filter

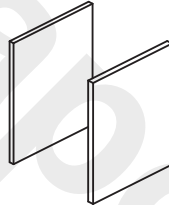

1x Velcro pad set

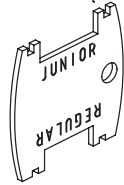

1x Outlet key

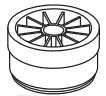

1x Flow straightener moulding

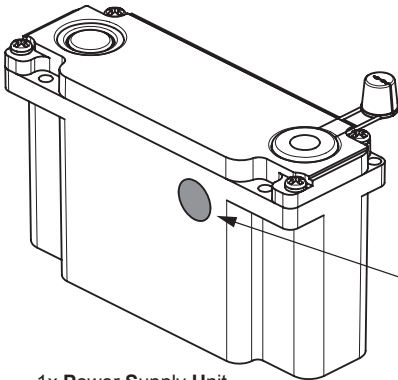

1x Power Supply Unit

Each type of PSU is identified by this coloured dot system:



MAINS



LINK
(Supplied with link cable)



BATTERY
(Supplied with battery)

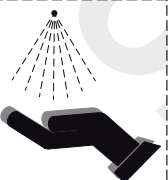

2x wall / panel stickers

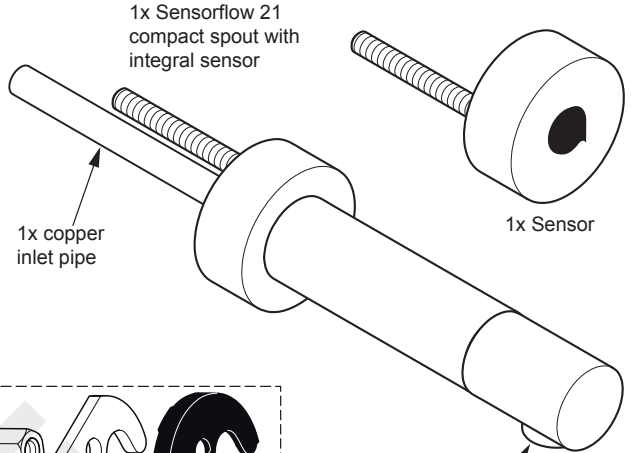

1x Sensorflow 21 compact spout with integral sensor

1x copper inlet pipe

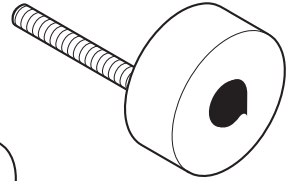

1x Sensor

Regulated PCA outlet pre-fitted. See section 8



Abbreviations & terminology used

PSU: Power Supply Unit, either mains, battery or link versions.

PCB: Printed Circuit Board inside the PSU.

RCD: Residual Current Device

SELV: Safety Extra Low Voltage

LINK PSUs: (up to 5 max) can be connected in series to a single mains PSU. Permitting washroom with multiple products to be run from a single mains supply point.

3 SUPPLY CONDITIONS

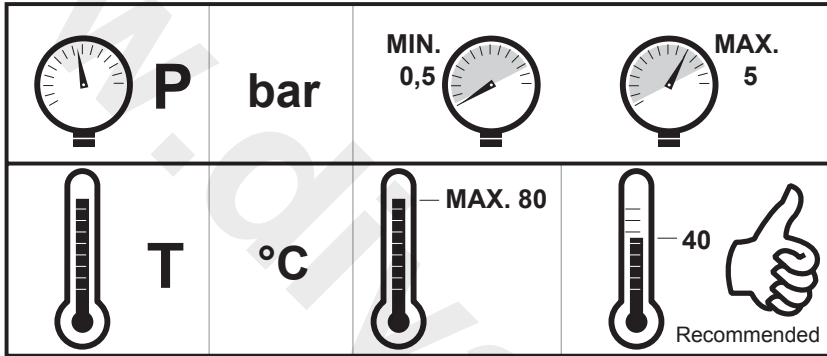

This product is designed to be supplied with water at a pre-mixed temperature or with cold water only.

In order to maintain water quality, the hot supply should be stored & distributed at a temperature greater than 55°C.

Use of an appropriate temperature reduction device (e.g. tee pattern thermostat) is recommended to ensure delivery of safe hot water temperatures from the spout.

Avoid supplying scalding water to the spout. Hot water temperature supply should be controlled to circa 40°C.

4 WATER REGULATIONS

The fittings covered by this installation and maintenance instruction should be installed in accordance with the water regulations published in 1999*, therefore Armitage Shanks would strongly recommend that these fittings are installed by a professional installer

*A guide to the Water Supply (Water Fittings) Regulations 1999 and the Water Byelaws 2000, Scotland is published by WRAS (Water Regulations Advisory Scheme) Fern Close, Pen-y-Fan Industrial Estate, Oakdale, Newport, NP11 3EH.
ISBN 0-9539708-0-9

5 INSTALLATION GUIDE



Before connection, flush water through pipe-work to remove all debris etc. to prevent damage to the valve mechanism.

THEN ENSURE WATER SUPPLIES HAVE BEEN ISOLATED.

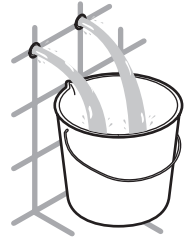

5.1 Mounting

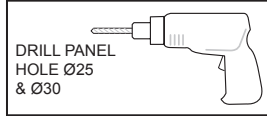

INSTALLATION HEIGHT: we recommend the spout outlet be positioned approximately 150-200mm above the basin or worktop (which ever is higher). Greater height may cause users to splash water outside the basin whereas lower height may affect activity space. Consideration should also be given to the overall aesthetical appearance. Installations vary significantly, so use this dimension as a guideline only.

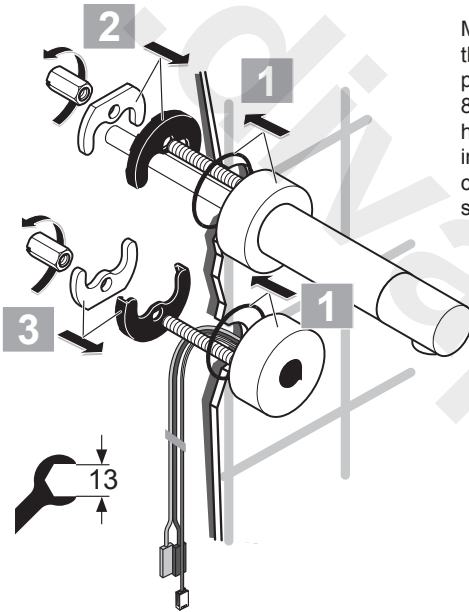

Mark the position of the spout onto the panel at the preferred location & drill a hole Ø30. Mark the position of the sensor onto the panel approximately 80 to 90mm below the spout centre line. Drill a hole Ø20. Upper hole is for the spout fixing stud & inlet pipe. Lower hole is for the sensor fixing stud & cables. Ensure the holes remain within the areas sealed by the foam gaskets.

1. Screw the copper inlet pipe into the spout, trim to length if necessary. Ensure the foam gaskets are in place as shown. These gaskets should already be fitted into the recess at the rear of the spout & sensor (self adhesive). The M8 fixing studs should also be pre-fitted. Offer the spout towards the upper hole in the panel.

Feed the inlet pipe & fixing stud through the panel hole. Push the spout against the panel & ensure the foam gasket makes contact. Similarly offer the sensor towards the lower panel hole, push the fixing stud & cables through & park it against the panel.

2. Fit the two rubber mouldings onto the metal fixing plates. Then from behind the panel slide the fixing plate assemblies onto the fixing studs as shown.

3. Hand tighten the nuts against the fixing plates until the rubber mouldings make contact with the rear of the panel. Ensure the spout & sensor are positioned correctly, & then tighten the nuts securely with a 13mm A/F spanner.

CABLE COLOURS:

The cables emerging from the spout are connected to the integral sensor.

BLACK & RED cables will connect to the solenoid valve.

GREY cable will connect onto the PCB inside the PSU

Do not cut these cables.



DO NOT apply heat near this product. Heat generated by soldering could damage plastic parts and seals.

INSTALLATION GUIDE continued...

5.2 Plumbing Overview

Once the spout has been secured to the panel, consideration should be given to installing & positioning of the inline valves.

A typical plumbing installation example is shown here. The water is being supplied from below, but can be from any direction.

Short lengths of Ø15mm copper pipe (not supplied) have been used between the components. Copper pipe lengths should be cut to suit the installation. Note the Ø10mm inlet pipe (fitted to spout) can be trimmed if necessary.

Observe arrow markings on the valves as shown here. Ensure water flows in the direction indicated.

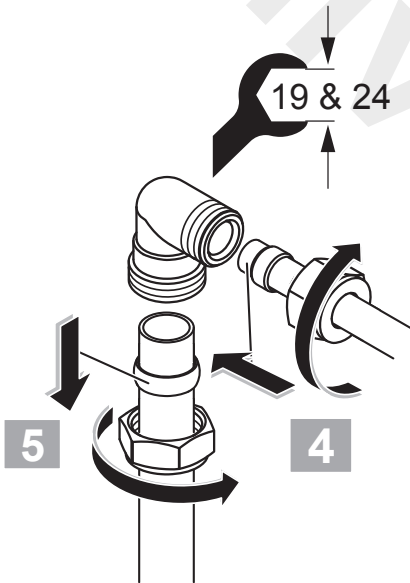

4. To fit inlet elbow: Slip the small compression nut & olive onto the Ø10mm inlet pipe. Push the elbow onto the inlet pipe up to the shoulder. Slide the olive up to the elbow & tighten the compression nut (19mm A/F) with a spanner. Hold the elbow steady with suitable grips.

ENSURE INLET PIPE REMAINS SECURELY SCREWED INTO SPOUT.

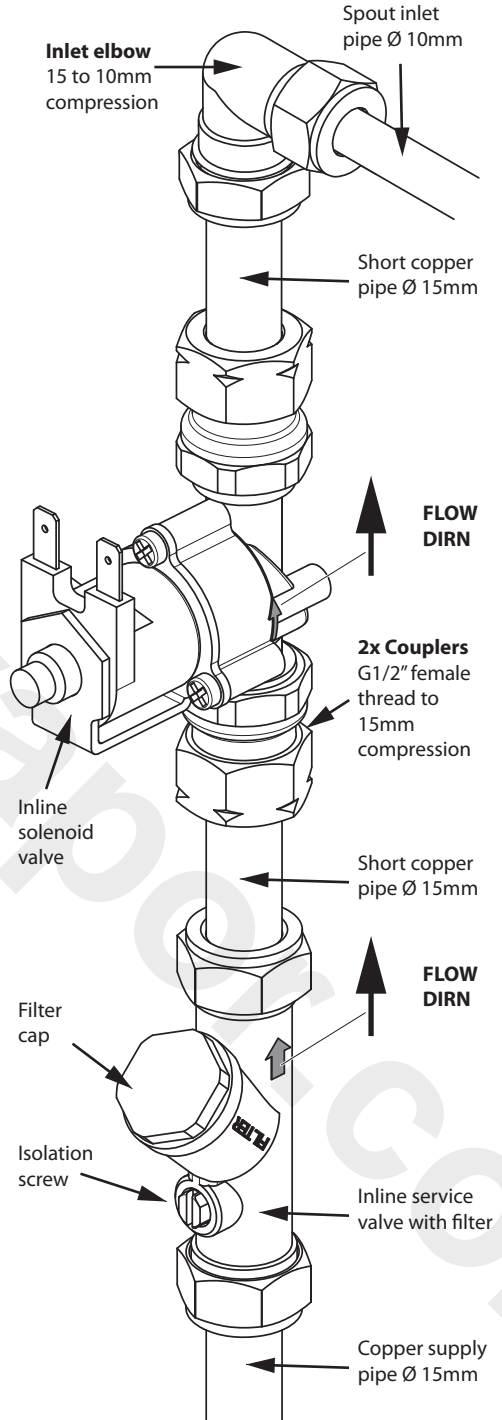

INSTALLATION GUIDE continued...

5. To fit inlet elbow cont: Slip the larger compression nut & olive onto a short length of Ø15mm supply pipe. Push the supply pipe into the elbow up to the shoulder. Slide the olive up to the elbow & tighten the compression nut with a 24mm A/F spanner. Hold the elbow steady with suitable grips.

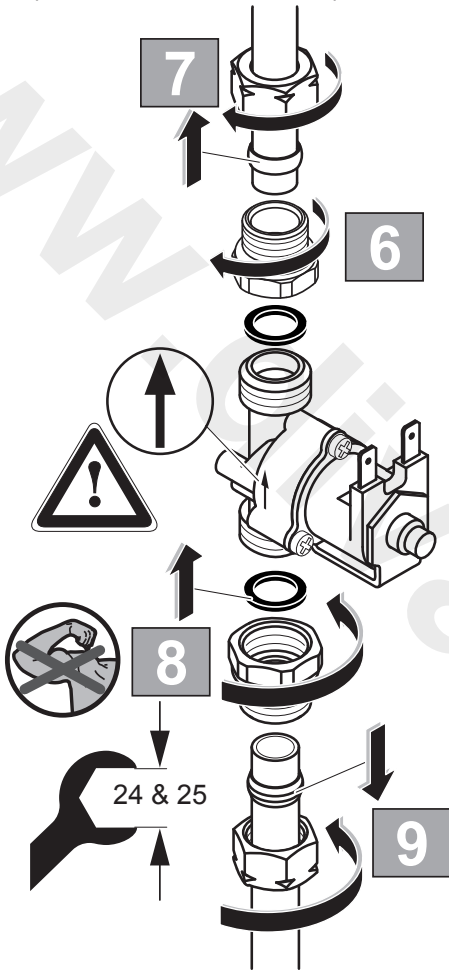

6 & 8. To fit solenoid valve:

The couplers can be screwed onto both sides of the in-line solenoid valve. Ensure the seals provided are fitted as shown. Make good the joints, taking care not to use excessive force. Tighten with an adjustable spanner (25mm A/F).

7 & 9. Slip the compression nuts & olives onto the pipes. Fit the solenoid valve into the pipe-work & make good the joints. Observe flow direction.

Make sure the solenoid valve is orientated such that the electrical connectors are easily accessible.

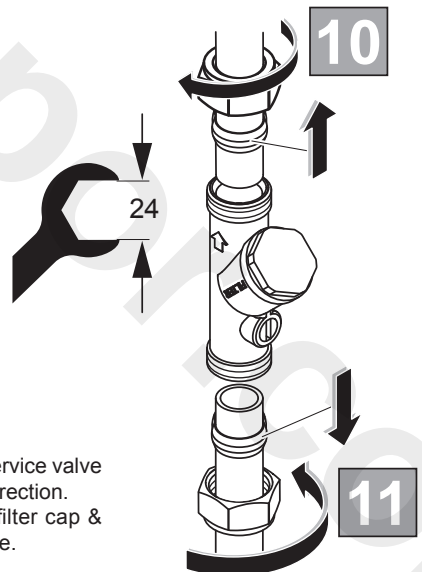

10 & 11. To fit service valve:

Slip the compression nuts & olives onto the pipes. Fit the service valve into the pipe-work & make good the joints. Observe flow direction. Make sure the service valve is orientated such that the filter cap & isolating screw are easily accessible for future maintenance.

When the isolator screw slot is parallel to the valve body, the valve is open & permits water to flow. To close the valve, rotate the isolator screw 90°.

Check that all joints are securely tightened, test for leaks.

INSTALLATION GUIDE continued...

5.3 Electrical connection

Connection of this product to mains power supply should be undertaken by a competent person and should conform to IEE Wiring Regulations

Orientation & position of solenoids, and PSU (Power Supply Unit) case can differ from installation to installation.

With the product securely mounted to the panel & plumbed-in, electrical work can commence.

12. Locate the end of the red & black cable which emerges from the spout (attached to the rear of the sensor). This cable length is nominal 750mm.

Connect the cable to the solenoid valve terminals as shown. Observe the + and - symbols marked on the solenoid valves, connect the red cable to + & black to -.

Refer to the diagram on the next page for PSU connection options.

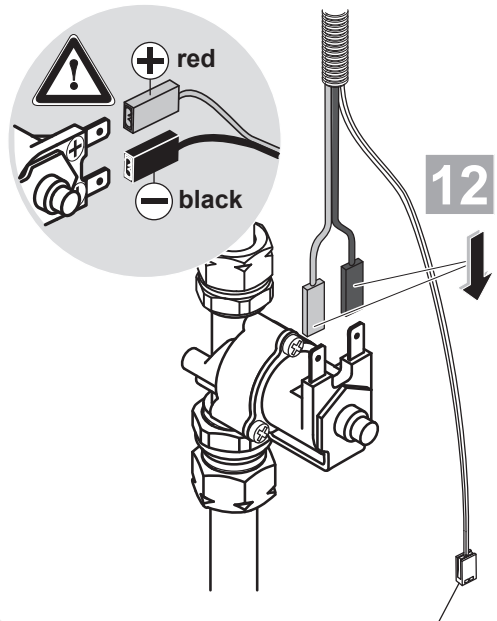

Each type of PSU is identified by this coloured dot system:

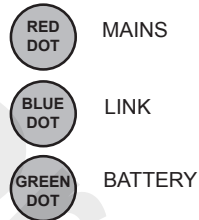

Electrical information & approvals:



Power: **6W**

Input voltage: **100V - 240V~ 50 - 60Hz**

Protection class: **II**

Approval EU: **EN 60950, EN 60335**

Approval UL: **UL 1310**

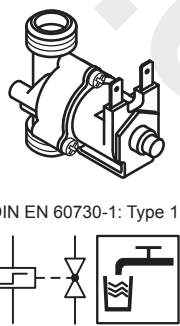

DIN EN 60730-1: Type 1

INSTALLATION GUIDE continued...

Electrical connection continued...

ENSURE MAINS POWER SUPPLY IS SWITCHED OFF BEFORE COMMENCING

13. Open the PSU case by unscrewing 4x posi-drive screws.

14. The lid & seal should separate from the PSU case.

15. For battery version, orientate the battery correctly & slide it into the PSU as shown, until it clicks into position
For mains version, slide out Printed Circuit Board (PCB).

16. For mains version, press out the "knock-out" at the base of the PSU case for mains cable entry.

17. For link version, slice the grommets fitted in the side wall of the PSUs to allow entry for the link cable(s).

18. For mains version, fit a grommet into the hole in the base of the PSU. Feed the power supply flexible cable through this grommet & make connections to terminal block on the PCB. Refer to 28.

19. For link version, feed the link cable through the side wall grommet in the PSU & plug it onto one of the sockets on the PCB. Refer to 28.

ALTERNATIVELY, the link cable can be routed through the PSU lid as shown in 24, along with the sensor cable.



20. Slide the PCB back into the PSU ensuring cables are not trapped.

21. For link version, plug the other end of the link cable into the socket on the link PCB.

22. For link versions, plug additional link cables into the sockets on the link PCB.

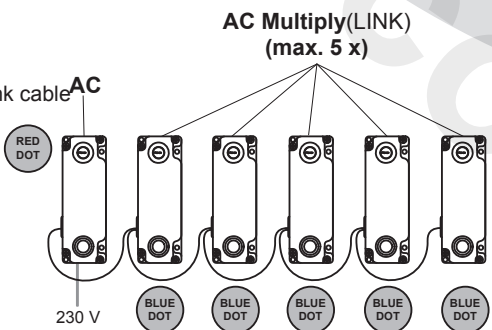
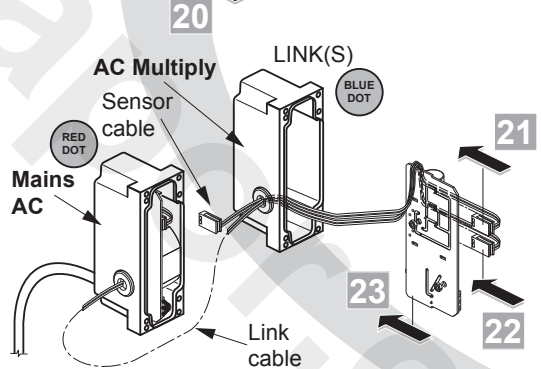
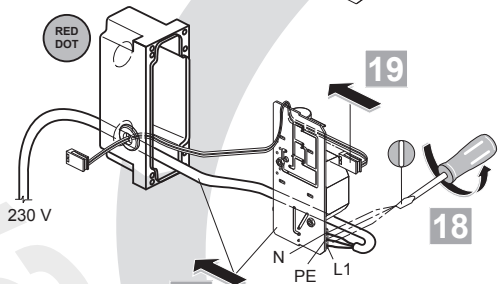
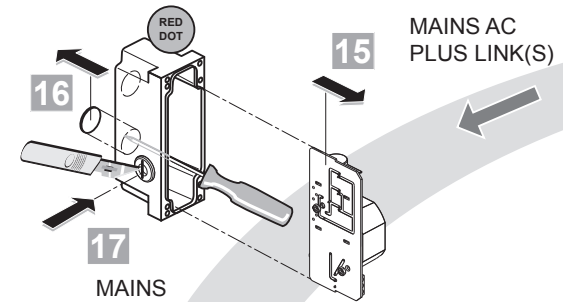
23. Slide the link PCB back into the PSU ensuring cables are not trapped.



Each type of PSU is identified by this coloured dot system:	
	MAINS
	LINK
	BATTERY

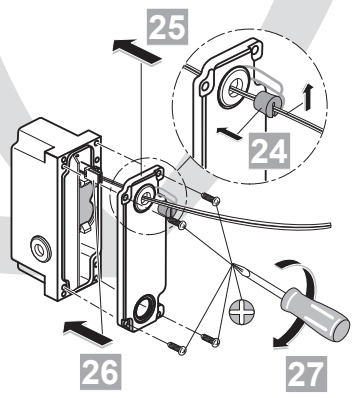
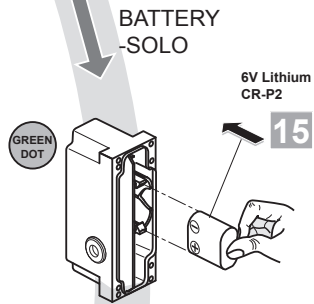
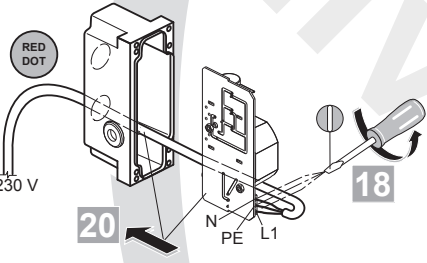
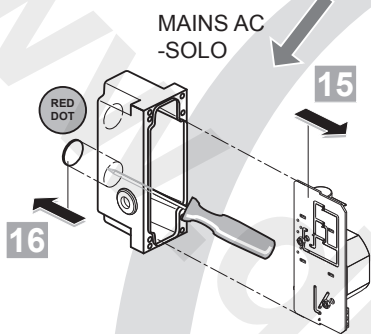
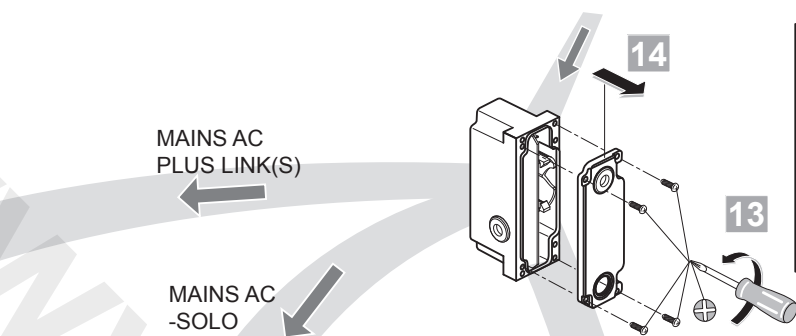

24. Remove the pre-split grommet from the PSU lid. Slide the grey sensor cable into this grommet.

25. Slide the sensor cable terminal through the PSU lid & plug into one of the sockets on the PCB. Press grommet securely into the lid.

26. Mate the PSU lid to the PSU case, ensuring seal is in place. Avoid trapping any cables.

27. Refit the 4 lid screws securely.

INSTALLATION GUIDE continued...

Electrical connection continued...

28. Mains power cable (not supplied) should be flexible 3A rated (multi-strand) 2 core cable. Prepare the cable for connection into the PCB by carefully stripping back the outer sheath by about 100mm. Strip the wire ends back by about 5mm.

PCB connection: the appropriate wires of the mains cable should be connected to the appropriate terminal on the block. The PCB is marked L1 for the live wire & N for the neutral wire. Earth connection is not required.

IMPORTANT: Ensure terminal block screws are firmly tightened & clamp the wires securely.

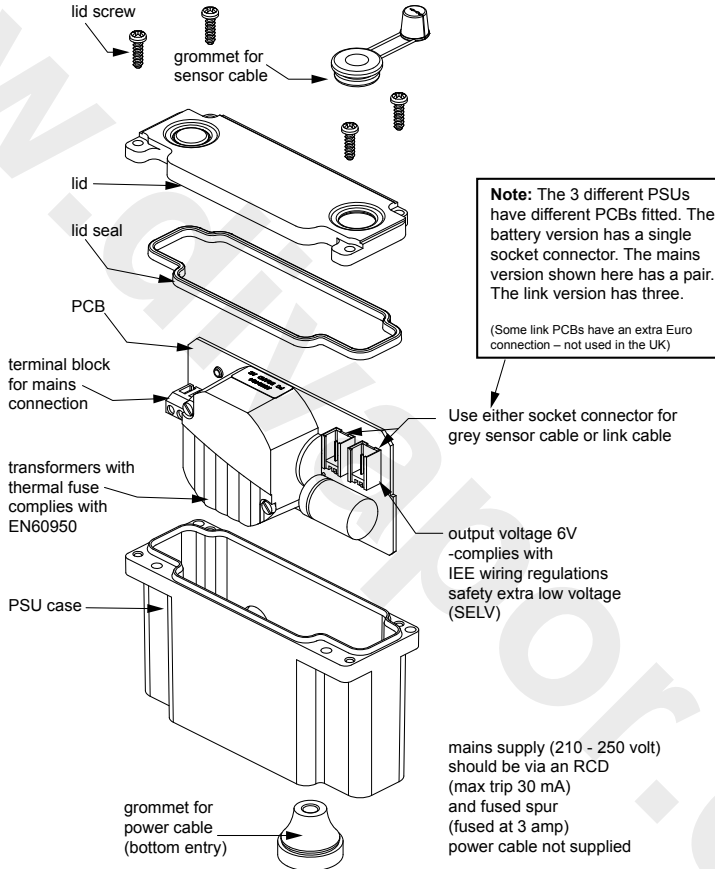

Shown above: Mains Power Supply Unit (PSU)

Other cable information:

Two cables emerge from the sensor housing these are connected to the sensor. Both cables have nominal lengths of 750mm.

BLACK & RED cable will plug onto the terminals on the solenoid valve.

GREY cable (with black line) will plug into one of the sockets on the PCB inside the PSU.

Link cable is also GREY (with black line), length is 1.5M (supplied with link product only)
SEE SECTION 7 FOR CABLE EXTENSION DETAILS & FURTHER CABLE NOTES

INSTALLATION GUIDE continued...

Electrical connection continued...

A pair of self-adhesive Velcro-type pads are provided. Attach one to the side of the PSU case & the other to a suitable location on the rear of the mounting panel.

Ensure the selected location does not stretch/stress the cables. Consideration should also be given to keeping the PSU case within easy reach/access for maintenance staff.

IMPORTANT:

Leave the sensor protective sticker in place for at least 20 seconds after powering-on the product. See section 7 regarding sensor ranging.

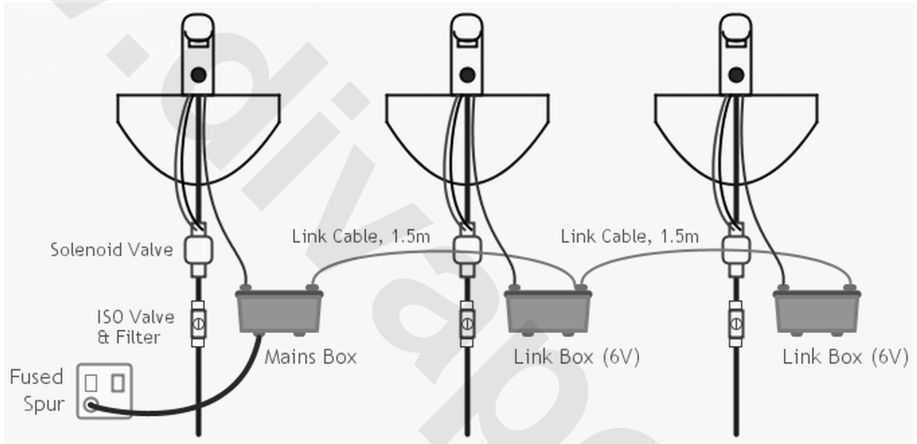

Example of an installation where 1st PSU is mains plus 2x link PSUs.

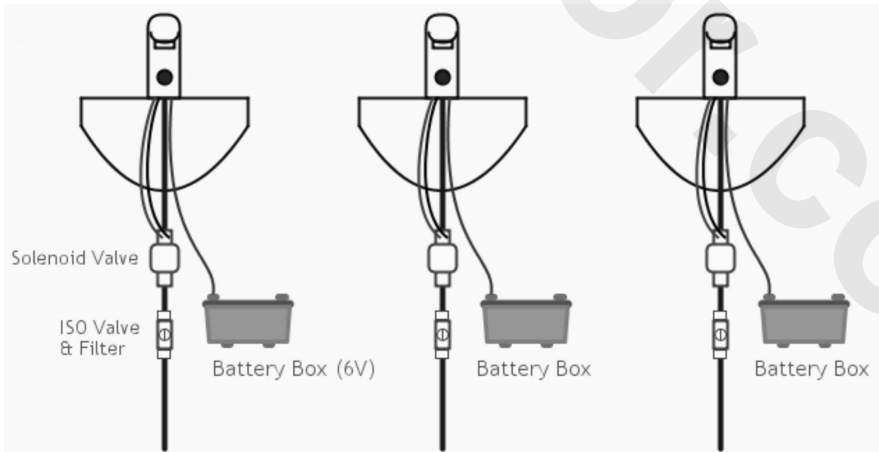

Example above of an installation where PSUs are all battery versions..

INSTALLATION GUIDE continued...

Electrical connection continued...

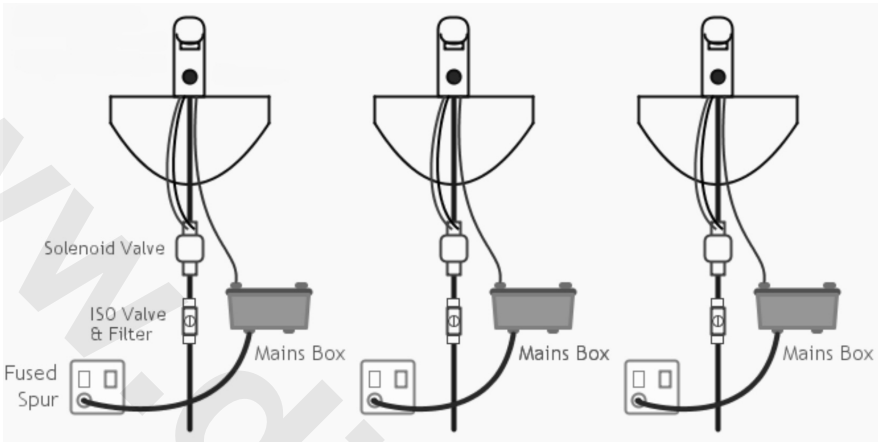

Example above of an installation where PSUs are all mains versions.

Sensor taps stickers: To complete the installation, 2 stickers are provided which can be stuck onto a wall or panel in close proximity to this product to advise the end user that this product sensor operated.

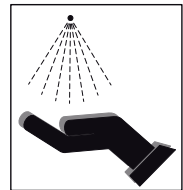

6 TAP OPERATION



Sensorflow 21 products use an Infrared Sensor to activate the system. The sensor is triggered by something reflective (normally hand movement) in the Sensing Region.

Move hands towards the spout: Water will flow.

Move hands away from the spout: Water will continue to flow for a second or two, and then turn off.

Sensor is factory set to **Proximity Mode**, & is designed to trigger the water flow **only when a hand (or similar) is in the Sensing Region** – just in front of the sensor / outlet.

The sensor is located in the separate sensor housing & is forward facing

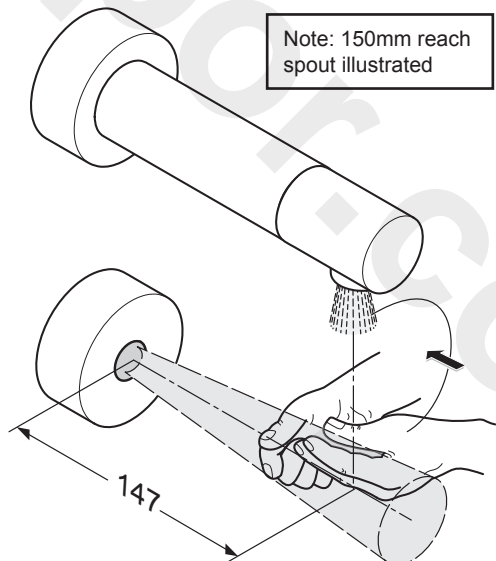

Note: 230mm reach spout is set to 227mm range.

7 SENSOR RANGING

If the Sensor detects a strong reflection (or similar), the spout will turn on and off intermittently with no one present (Pulsing On / Off). In the unlikely event that this does happen, the Sensing Range must be reduced.

Ranging can be done using one of two ways: (A) manually or by (B) using a remote sensor programming unit.

**Factory default ranges are set to:
147 mm (150 spout) &
227 mm (230 spout).**

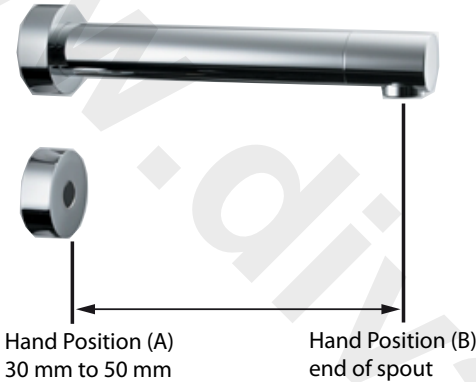

A. Manually Changing Sensor Range

1. Turn Power to sensor OFF.
2. Wait 30 seconds, turn power ON . . .
3. **IMMEDIATELY** move hand very close to sensor (A) (palm towards sensor)
4. Leave hand in place for 7 seconds.
5. Move hand to Position (B)
(This will set the Sensing Range)
6. Leave hand in place for 7 seconds
Move hand away from Sensor / Tap.
7. Wait 5 seconds for sensor to store data.
8. Sensor Range is now set.
9. Check tap works properly by bringing hand towards tap.

(Total range is from 50mm to 250mm).

**DURING SETTING UP
PROCEDURE AVOID HIGH
VISIBILITY CLOTHING**



B. Remote sensor programming unit is a hand held unit which can be used to change sensor range & other functions if required. Detailed instructions for using this unit are provided with the unit. (This unit can be purchased separately. For spares code, see section 10)

See maintenance section for a quick overview of how to use this unit to evoke the optional hygiene flush function.



Extension cables

If the installer wishes to position the PSU in the ceiling area for example, then cable extensions are available:

SENSOR & SOLENOID EXTENSION LEADS: A963703NU: (Pair, 2M long).
Containing grey power lead for sensor & black/red lead for solenoid.

LINK CABLES: A962281NU (1.5M), A962282NU (3M) & A960707NU (10M).



CABLES SHOULD NOT BE CUT (OR SHORTENED), AS THIS WILL INVALIDATE WARRANTY.





For more information on spare parts why not visit our spare website:
www.fastpart-spares.co.uk. Or contact customer care

8 OUTLET OPTIONS



This product comes with two outlets one fitted & the second supplied in a bag. The product is factory fitted with a laminar PCA regulated outlet which is secured within an anti-vandal (AV) housing.

Unregulated full-flow flow straightener (SUPPLIED LOOSE)	P 0.5 bar 	Q 4.2 l/min 
Regulated PCA outlet (> 1.0 bar) (FACTORY FITTED)	P 3.0 bar 	Q 4.7 l/min 

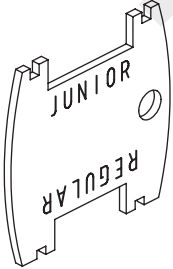

To replace/clean/service the outlet, use the outlet key supplied with the product to unscrew the AV housing. Using the side of the key marked "junior" locate the key into the inner ring of the housing and unscrew. Change the outlet & re-secure the housing with the key, ensuring the seal is in place.

Ensure the outlet housing is adequately tightened to prevent leaks & run back.

9 MAINTENANCE

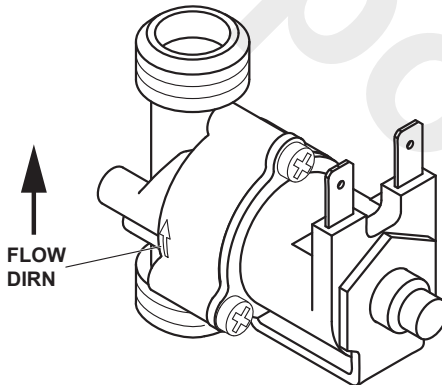

9.1 SOLENOID VALVE

If **water continues to flow** when the tap should be off, and if the sensor is correctly ranged, then the solenoid valve may have debris lodged in the diaphragm pilot hole or on the valve seat:

- Locate the solenoid valve.
- Isolate the water supplies.
- Disconnect the solenoid valve cables.

Maintenance continued...

- Remove the 3 screws holding the coil.
- Lift off the coil assembly.
- Locate the diaphragm (inside the valve body).
- Clean out the pilot hole(s) – use a thin gauge fuse wire (or similar).

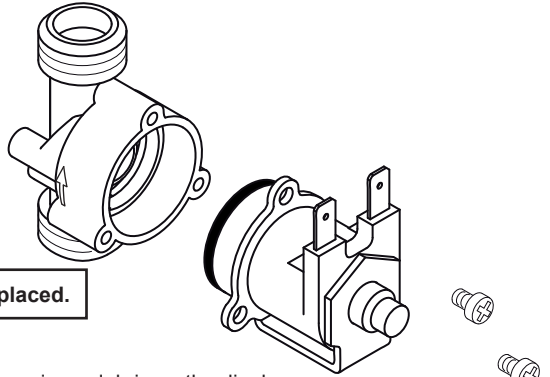

If diaphragm is damaged it should be replaced.

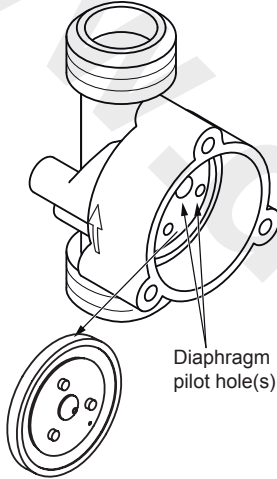

- Ensure there is no debris on the diaphragm or the valve seat (under diaphragm).
- Re-assemble solenoid valve.
- Reconnect water supply, check there are no leaks.
- Reconnect the solenoid valve cables.
- Test the solenoid valve & ensure it is working correctly.

If the solenoid plunger becomes dislodged from its bore, **ensure it is refitted correctly. The end with the small black insert should face towards the diaphragm.**

Incorrect assembly will cause continual running.



9.2 Hygiene flush (Automatic)

This hygiene flush is an important optional function of these products which can be enabled by the installer or maintenance staff using the optional remote programming unit (for part number see sect.10).

The hygiene flush is used to combat periods of stagnation due to low usage of the product. The function activates the spout automatically if it hasn't been used for a set time period. This function ensures regular movement of water combating bio film growth and bacteria colonisation.

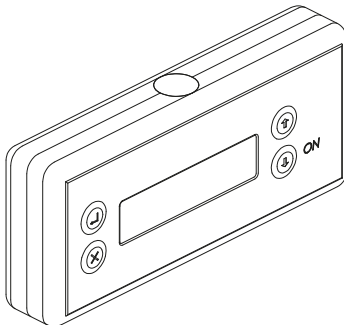

The programming unit should be held pointing towards the sensor at distance of approx. 100mm.

Once enabled, this function will automatically turn the water on for a duration of 1 to 240 seconds if the product has not been used for a period of 6, 12, 24, 48, or 72 hours.

For full details on how to enable this function, refer to the programming instructions supplied with programming unit.

Keep hand unit away from the water flow, avoid getting it wet.

Maintenance continued...

A brief summary of how to navigate the programming unit is as follows:

- a) Handunit ON
- b) Navigate to Menu 4 **PARAMETER**
- c) **SENSOR 2013** (Enter)
- d) **MENU 4.1 HAND-WASH** (Enter)
- e) **AUTO-RINSE FREQUENCY: OFF**
ARROW UP (To required Delay time) (Enter). Recommended: 6 or 12 hours.
- f) **AUTO-RINSE DURATION: (15 sec default)**
ARROW UP or DOWN (To required Run Time). Recommended: 60sec (max).
- g) Point towards Sensor (approximate distance 100mm)
- h) Press ENTER
- i) **TRANSMISSION OK** - if successfully programmed;
ERROR COMMUNICATION 2 - if programming failed
- j) Press ESCAPE (X) to get **BACKUP FUNCTION**
- k) With BACKUP FUNCTION, previous settings are 'Remembered'
- just point at next Tap / Sensor and press ENTER to repeat.
- l) Handunit turns itself off after 2 minutes of non-use.

Note: Older handset units will display (c) **SENSOR 2008** (or 2003) by default.
Failed program output message will be (i) **ERROR COMMUNICATION 3**.
Latest handset can program all previous sensor versions 2013, 2008 & 2003.

9.3 Isolating valve

Isolation valve (supplied with this product) **MUST** be fitted to permit future maintenance of the product. A strainer (filter) is built into this valve.

Isolation valve should be installed in an easily accessible location.

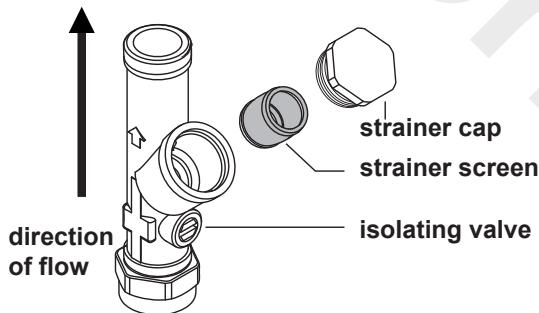

When the isolator screw slot is parallel to the valve body, the valve is open & permits water to flow. To close the valve, rotate the isolator screw 90°.

The filter can be checked & cleaned by unscrewing the cap using a 22mm A/F spanner. Expect some water to escape. The isolating valve can be closed to permit servicing of the solenoid valve, or to remove the product completely.

10 SPARE PARTS

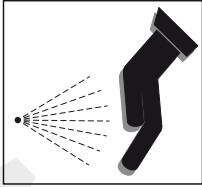

A 960 402 NU
Legend plates

B 960 860 NU
Flow straightener insert

B 960 859 AA
Aerator complete
with AV key

A 963 667 NU
Grub screw

A 961 182 NU
O-ring only (x2)

X



A 960 219 NU
Sensor complete

A 960 224 NU
Diaphragm (10 pk)

A 962 478 NU
Solenoid complete

A 962 499 NU

E 960 086 NU

A 961 798 NU
O-ring

A 961 338 NU
O-ring

B 960 459 NU
Inlet tube

A 962 499 NU

A 4180AA

A 4183AA

A 960 704 NU
Velcro pads

A 960 219 NU
Sensor complete

A 962 478 NU
Solenoid complete

A 962 499 NU

E 960 086 NU

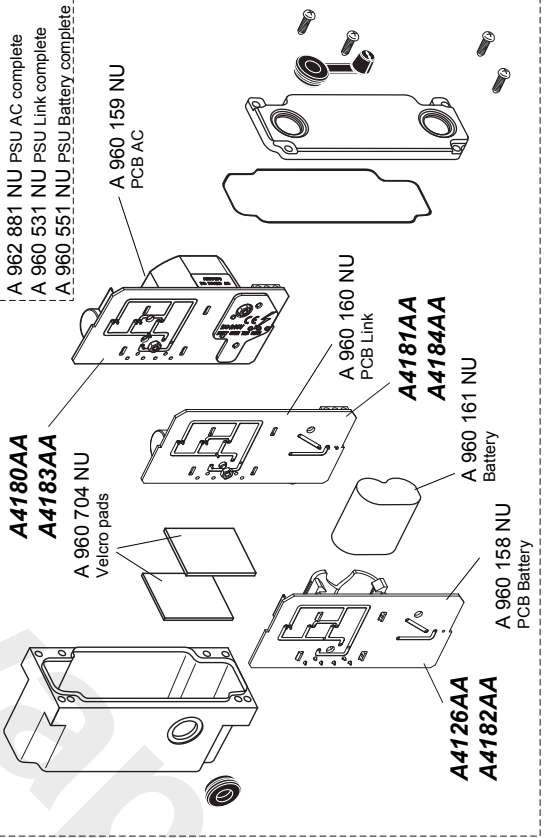

A 962 881 NU PSU AC complete
A 960 531 NU PSU Link complete
A 960 551 NU PSU Battery complete

A 960 159 NU
PCB AC

A 960 160 NU
PCB Link

A 4181AA

A 4184AA

A 960 161 NU
Battery

A 960 158 NU
PCB Battery

A 4126AA

A 4182AA

FOR LONGER CABLE OPTIONS,
REFER TO SECTION 7



For more information on spare parts why not visit our spare website:
www.fastpart-spares.co.uk. Or contact customer care

11 CLEANING CHROME SURFACES

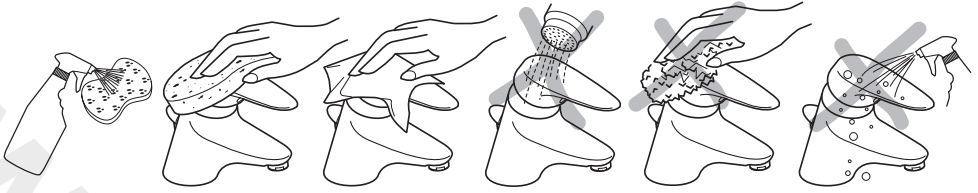

When cleaning chromed products use only a mild detergent, rinse & wipe dry with a soft cloth. Ideally clean after each use to maintain appearance.

Never use abrasive, scouring powders or scrapers. Never use cleaning agents containing alcohol, ammonia, hydrochloric acid, sulphuric acid, nitric acid, phosphoric acid or organic solvents. Use of incorrect cleaning products / methods may result in chrome damage which is not covered by the manufacturer's guarantee.

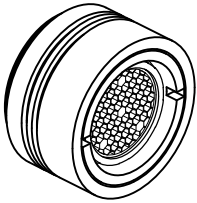

Outlet cleaning. On a regular basis the outlet should be inspected & cleaned. To unscrew and remove the outlet, see section 8. In areas where lime scale build-up is prevalent this should be avoided by regular cleaning. If it should build up, it will have to be removed. An inhibited proprietary scale solvent can be used such as a kettle de-scaling solvent but it is important to follow the manufacturer's guidelines. After de-scaling it is important to rinse the parts thoroughly in clean water. Clean carefully and do not use abrasive materials or scrapers.



For more information about our products visit our websites:

www.armitage-shanks.co.uk

www.idealspec.co.uk

www.fastpart-spares.co.uk

AFTER SALES NON RESIDENTIAL HELPLINE

0870 122 8822

AFTER SALES NON RESIDENTIAL FAX

0870 122 8282

E-MAIL

aftersalesnonresidential@idealstandard.com

0116 / A 866 852

Made in Germany

Armitage Shanks pursues a policy of continuing improvement in design and performance of its products.

This right is therefore reserved to vary specification without notice.

Armitage Shanks is a division of Ideal Standard (UK) Ltd

Armitage Shanks

The Bathroom Works, National Avenue

Kingston-upon-Hull, HU5 4HS England

*Armitage
Shanks*

Ideal Standard International NV
Corporate Village - Gent Building
Da Vincilaan 2
1935 Zaventem
Belgium

